

# U.S. MISSILE LAUNCH VEHICLE

## 1/12 SCALE SIMULATION MODEL

- BEARING TYPE TRAILER BODY, THE WHOLE CAR ALLOY MATERIAL HEAVY CHASSIS.
- SHOCK TUBE+DOUBLE PLATE SPRING NON INDEPENDENT DAMPING SYSTEM.
- INDEPENDENT REMOTE CONTROL AND TRACTOR REMOTE CONTROL.
- HIGH-POWER ELECTRIC PUSH AND PULL ROD IT CAN LIFT THE WHOLE CAR OFF THE GROUND.
- THE MISSILE LAUNCH TOWER AND RADAR CAN BE ROTATED 360° CLOCKWISE AND ANTICLOCKWISE CONTINUOUSLY.



# KIT VERSION

**1:12**  
1:12 SCALE  
MODEL

**MULTI-FUNCTION**  
REMOTE CONTROL

**SURGE ABSORBER**  
ASSEMBLY

**ALL-TERRAIN**  
SUSPENSION

**SLOW DOWN**  
MOTOR

**DIY**  
ASSEMBLY

(使用说明书)  
(Instruction manual)

**2.4 GHz**  
CONTROL SYSTEM

**14+**  
AGES

产品仅适合14岁以上年龄使用  
(Not suitable for under 14 years old)

HENGGUAN TECHNOLOGY

TRASPED

NO. HG-P805



## 安全措施 (Safety precautions)

此遥控模型并非普通玩具，操作前先按说明书步骤完成组装。

This remote control model is not an ordinary toy. It should be assembled according to the instructions before operation.

## 操作遥控模型时注意事项 (Cautions to observe when operating R/C models)

1. 请选择不妨碍他人的地方完成模型组装，组装完成后请在空旷无人的地方操控模型；
  2. 切勿在路上使用遥控模型车。
  3. 切勿在人多的地方或靠近小孩的地方驾驶遥控模型车
  4. 请勿在拥挤的地方或室内操作遥控模型车。
  5. 请勿在其他不适当的区域操控遥控模型。
1. Please select a place that will not interfere with others to complete the model assembly. After the assembly is completed, please control the model in an empty place.
  2. Do not use remote-controlled model cars on the road.
  3. Do not drive the remote control model car in crowded places or near children.
  4. Do not operate the remote control model car in crowded places or indoors.
  5. Do not operate the remote control model in other inappropriate areas.

## 导弹车连接拖头车时注意事项 (Cautions when connect missile car connect to tractor)

连接拖头操作时，请遵循下面列出的正确的遥控模型开启/关闭程序，否则遥控模型可能失控导致严重事故。

When connecting the tractor, please follow the correct opening/closing procedure for the remote control model listed below, otherwise the remote control model may get out of control and cause serious accident.

1. 将遥控模型放置在支架上，使其车轮悬空；
  2. 将信号线（延长线）连接到拖头内的接收机上；
  3. 另一端再连接UBEC电源（注意不得反接正负极）；
  4. 连接电池，打开电源开关，接收机通电；
  5. 打开发射器电源开关。
1. Place the remote control model on the bracket with the wheels suspended;
  2. Connect the signal wire (extension wire) to the receiver in the tractor head;
  3. The other end is then connected to UBEC power supply (pay attention not to reverse connection of positive and negative poles);
  4. Connect the battery, turn on the power switch and energize the receiver;
  5. Turn on the transmitter.

## 遥控模型关闭顺序相反 (Opposite sequence for shutting down R/C model)

1. 关闭接收机电源；
  2. 关闭发射器（遥控器）；
  3. 断开并拿出电池。
1. Turn off receiver power;
  2. Turn off the emitter(transmitter);
  3. Disconnect and remove the battery.

## 警告 (Warning):

1. 切勿让手指、头发、衣服等触摸到任何转动部件，如轮子、传动轴或齿轮，可能会导致严重的伤害。  
Do not allow fingers, hair, clothing, etc. to touch any moving parts such as wheels, shafts or gears, which may cause serious injury.

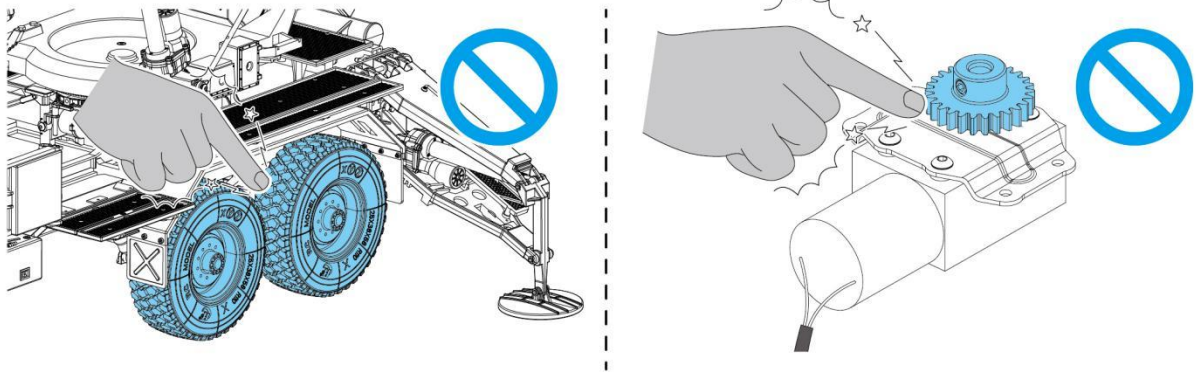

2. 切勿将手伸入到摆臂（支撑脚）、旋转底座或升降塔台，以防意外伤害。  
Do not put your hand into the swing arm (supporting foot), rotating base or tower to prevent accidental injury.

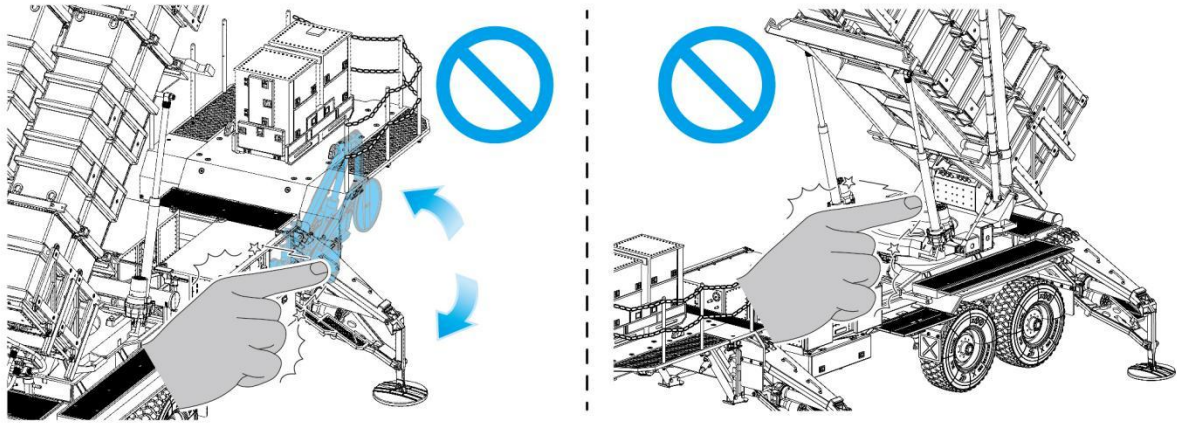

3. 小心另一个遥控频率的干扰。请使用本厂专用的发射机操作遥控模型。  
Watch out for interference from another remote frequency, please use our special transmitter to operate the remote control model.

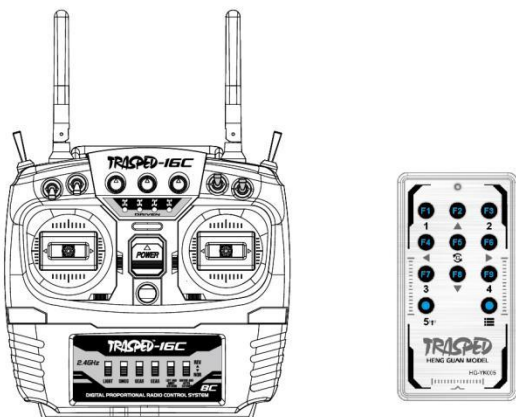

4. 确保在你的操作区域没有其他人使用与你相同的频率。同时使用相同的频率，都可能导致遥控模型失去控制，导致严重事故。  
Make sure that no one else in your area of operation is using the same frequency as you. Using the same frequency at the same time can cause the remote control model to lose control, leading to a serious accident.

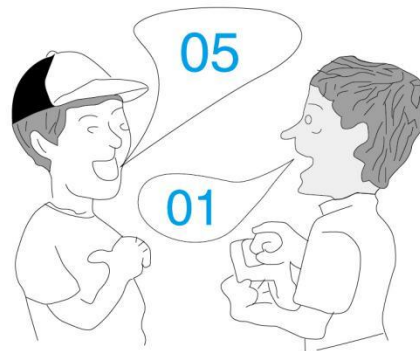

5. 在布线、连接和绝缘电缆时要格外小心。
  6. 确保电线连接牢固，组装前请仔细检查连接线是否破损，切勿使用损坏的电线，损坏的电线是非常危险的，会引起短路导致火灾。请在您当地的专业商店修理电线。
  7. 运行到极限或卡死（受阻）时，应立即按停止键或断开电源，不得长时间处于卡死状态，长时间的受阻会使旋转部件的电机过热或部件损坏。
  8. 禁止擅自改装该模型产品，和不按规定操作模型由此引发的事故，后果自负！
5. Extreme care should be taken when wiring, connecting, and insulating cables.
  6. Make sure the wires are firmly connected. Please carefully check whether the wires are damaged before assembly. Do not use damaged wires, as damaged wires are very dangerous and may cause short circuit and fire. Please repair the wires at your local specialty store.
  7. When running to the limit or stuck (blocked), should immediately press the stop button or disconnect the power supply, shall not be stuck for a long time, long time blocked will make the motor of the rotating parts overheating or parts damage.
  8. Unauthorized modification of the model products is prohibited, and do not operate the model according to the provisions of the accident caused by the consequences!

### 电池 (Battery):

1. 发射机或接收机的电池电量不足，可能会导致模型失去控制。
  2. 长时间弱运行电池也可能导致电池损毁或电子配件设备损坏
  3. 当不使用遥控模型时，请务必及时断开并取出电池。
  4. 请勿私自拆卸电池或随意切断电池电线
  5. 运行电池短路，大约至少300w的电可以释放，导致火灾或烧伤。
1. Low battery power in the transmitter or receiver could cause the model to go out of control.
  2. Running the battery weakly for a long time can also lead to battery damage or damage to electronic components
  3. When the remote control model is not in use, be sure to disconnect and remove the battery in time.
  4. Do not remove the battery or cut off the battery wires without permission.
  5. Running battery short circuit. Approximately at least 300 watts of electricity can be released, causing a fire or burn.

### 正确充电 (The correct charging):

1. 持续充电可能会损坏电池，在最坏的情况下，可能会积累热量导致火灾。
  2. 如果电池在充电过程中变得非常热，请咨询您当地的爱好商店检查/维修。
  3. 禁止私自改装和维修充电器
  4. 不要在电池还热的时候给电池充电。
  5. 充电完毕后，请及时拔出充电器
  6. 如果你的遥控模型湿了，立即停止运行，因为可能导致短路。
  7. 请妥善处理电池。不要把电池放在火里。
1. Constant charging can damage the battery and, in the worst case, can build up heat and cause a fire.
  2. If the battery gets very hot during charging, please ask your local hobby store for a check/repair.
  3. Do not modify or repair the charger without permission.
  4. Do not charge the battery while it is still hot.
  5. Please pull out the charger in time after charging.
  6. If your remote control model gets wet, stop running it immediately, as it may cause a short circuit.
  7. Please dispose of the battery properly. Don't put the battery in the fire.

 **注意 (Warning):**



1. 在开始装配前仔细阅读并充分理解说明书。  
Read the instructions carefully and fully understand them before starting the assembly.



禁止14岁以下儿童使用。  
Forbid a child under 14 years of age an usage.

2. 禁止14岁以下年龄段人群使用该产品。  
People under the age of 14 are prohibited from using the product.



3. 首次装配模型者应请教有操作经验的人作相关指导。  
The first time assembler should consult the person with operation experience for relevant instructions



4. 在装配此套件时，需要使用刀具等工具，请小心处理刀具等工具；  
When assembling this kit, you need to use tools such as cutting tools, please handle with care;



5. 产品含有小且尖锐的零件，请放在儿童接触不到的地方。  
The product contains small sharp parts. Keep out of reach of children.



6. 不能让小孩把任何东西放进嘴里，也不能把塑料袋套在头上。  
Children should not be allowed to put anything in their mouths or put plastic bags over their heads.

**特别警告 Especially warning**



激光不可直视眼睛  
不可作为儿童玩具  
WORRY ABOUT LASER  
DON'T LOOK DIRECTLY

7. 产品含有激光照射，不可直视眼睛，更不可作为儿童玩具！  
Do not look directly into the eyes of the laser and cannot be used as a children's toy!



噪声有害  
NOISE IS  
HARMFUL

8. 组装模型或操控模型时可能会产生有害噪声，请注意作好防护！  
The assembly or control of the model may produce harmful noise, please pay attention to the protection!

## 遥控器功能介绍 Transmitter function introduce

### 8通 遥控器

### 8 Channels transmitter

左后摆臂往上摆  
Left rear swing up the arm

停止 CH9 左后摆臂控制  
Stop CH9 Left back swing arm control

左后摆臂往下摆  
Left rear swing arm down

左前摆臂往上摆  
Left front swing arm up

停止 CH9 左前摆臂控制  
Stop CH9 Left front swing arm control

左前摆臂往下摆  
Left front swing arm down

雾灯开关  
Fog lamp switch

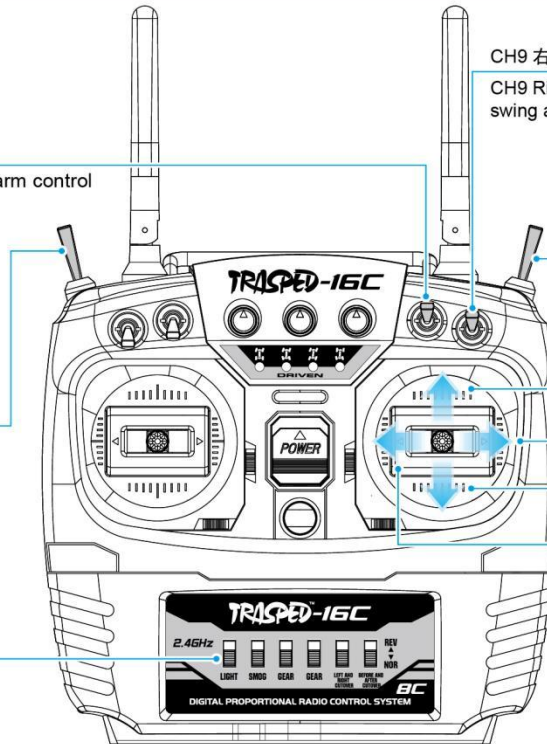

CH9 右后摆臂控制  
CH9 Right rear swing arm control

右后摆臂往上摆  
Right rear swing arm up

停止 Stop

右后摆臂往下摆  
Right rear swing down the arm

右前摆臂往上摆  
Right front swing up the arm

CH9 右前摆臂控制  
CH9 Right front swing arm control

停止 Stop

右前摆臂往下摆  
Right front swing arm down

导弹上升  
Missile rise

导弹右旋  
The missile rotates to the right

导弹下降  
Missile drop

导弹左旋  
The missile rotates to the left

注:

1. 该产品仅限使用本厂生产的8通方形遥控器操控。
2. 这是连接HG-P802牵引拖头的8通接收机时遥控操作功能指示, 本产品包装不配置该遥控器。

Remark

1. This product can only be operated by the 8ch square transmitter produced by our factory.
2. This is the remote control ation function indication when connecting the 8ch receiver of tractor HG-P802, This transmitter not configured in the packaging of this product.

### YK005 小遥控器 YK005 Small remote controller

注: 本产品包装标配独立操控小遥控器

Note: This product is packaged and assembled with an independent remote control

工作指示灯 Work indicator light

选择左前 Choose left front

选择4个支撑摆臂同时运转  
Choose the four supporting arms operate at the same time

导弹左旋 Missile turn left

选择左后 Choose left rear

操作向下 Operation down

选择升降 Choose up and down

同时按下为重新对频  
press at the same time to reset the frequency

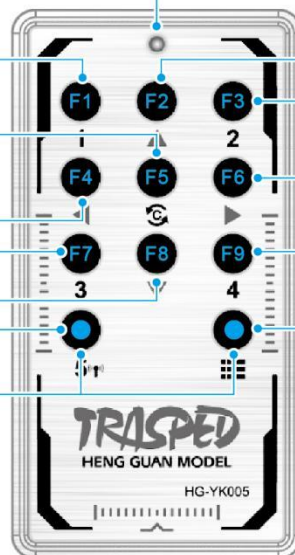

操作向上 Operation up

选择右前 Choose right front

导弹右旋 Right-handed missile

选择右后 Choose backward

M菜单功能键/雾灯开关  
M menu function button / Fog lamp switch

# 基本操作(Basic Operation)

## 1. 左前摆臂控制 Left front swing arm control

- ↑ 左前摆臂往上摆 (箭头方向)  
Left front swing up the arm (direction of arrow)
- 停止 Stop
- ↓ 左前摆臂往下摆 (箭头方向)  
Left front swing arm down (direction of arrow)

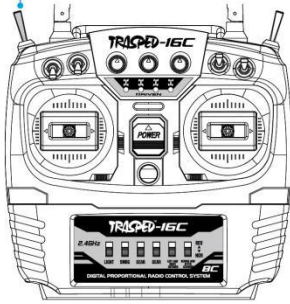

先按一下“F1选择左前”，用“F2操作向上”和“F8操作向下”控制左前摆臂上升和下降。  
Firstly press “F1 choose left front”, and then use “F2 operation up” and “F8 operation down” to control the left front swing arm up and down.

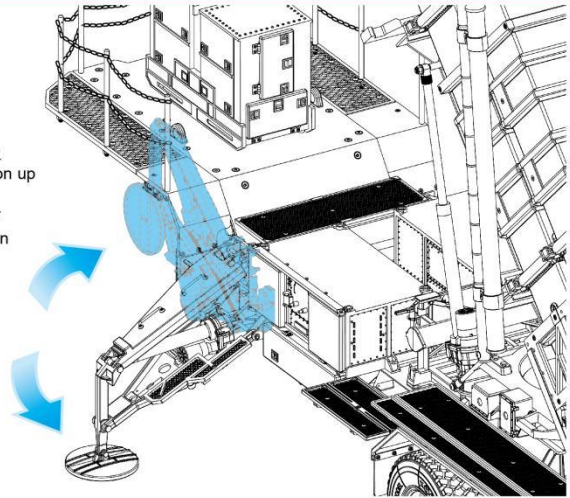

## 2. 左后摆臂控制 Left back swing arm control

- ↑ 左后摆臂往上摆 (箭头方向)  
Left back swing up the arm (direction of arrow)
- 停止 Stop
- ↓ 左后摆臂往下摆 (箭头方向)  
Left back swing arm down (direction of arrow)

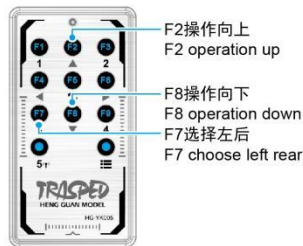
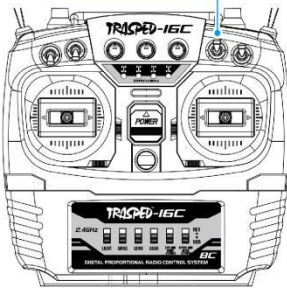

先按一下“F7选择左后”，再用“F2操作向上”和“F8操作向下”控制左后摆臂上升和下降。  
Firstly press “F7 choose left rear”, and then use “F2 operation up” and “F8 operation down” to control the left back swing arm up and down.

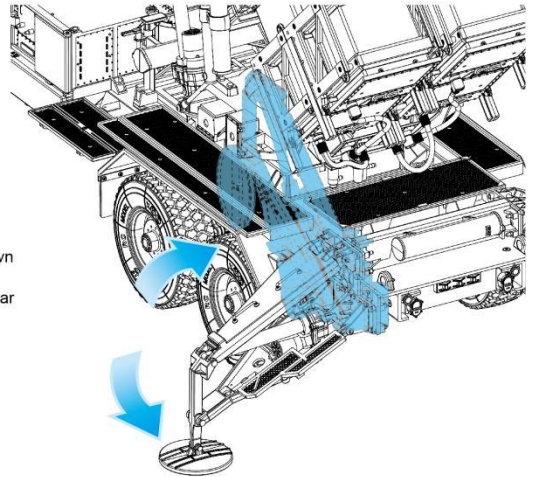

## 3. 右前摆臂控制 Right front swing arm control

- ↑ 右前摆臂往上摆 (箭头方向)  
Right front swing up the arm (direction of arrow)
- 停止 Stop
- ↓ 右前摆臂往下摆 (箭头方向)  
Right front swing down the arm (direction of arrow)

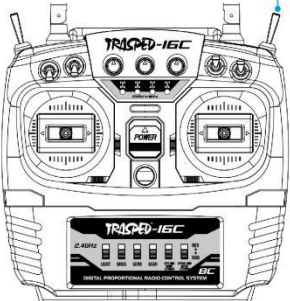

先按一下“F3选择右前”，用“F2操作向上”和“F8操作向下”控制右前摆臂上升和下降。  
Firstly press “ F3 choose right front”, and then use “F2 operation up” and “F8 operation down” to control the right front swing arm up and down.

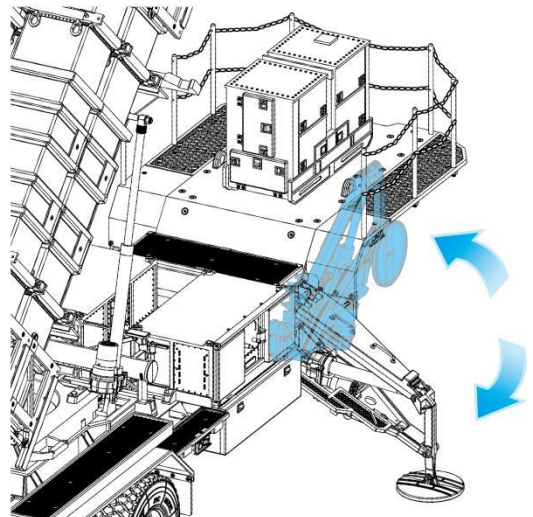

#### 4. 右后摆臂控制 Right back swing arm control

- ↑ 右后摆臂往上摆 (箭头方向)  
Right back swing arm up (direction of arrow)
- 停止 Stop
- ↓ 右后摆臂往下摆 (箭头方向)  
Right back swing arm down (direction of arrow)

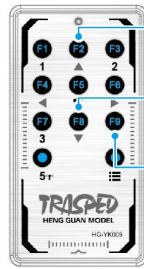
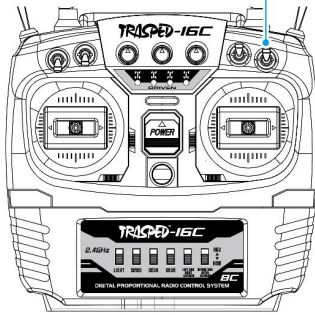

- F2操作向上  
F2 operation up
- F8操作向下  
F8 operation down
- F9选择右后  
F9 choose right rear

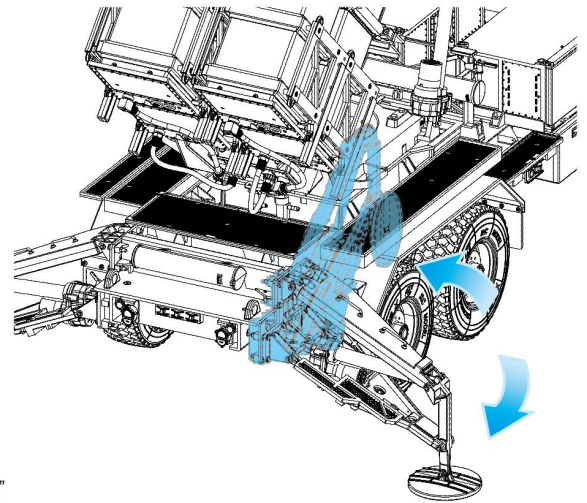

先按一下“F9选择右后”，再按“F2操作向上”和“F8操作向下”控制右后摆臂上升和下降。  
Firstly press “F9 choose right rear”, and then press “F2 operation up” and “F8 operation down” to control the right back swing arm up and down.

#### 5. 4个支撑摆臂升降控制 Four supporting swing arms lift control

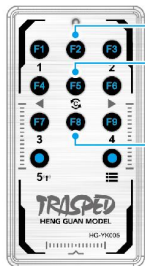

- F2操作向上 F2 operation up
- F5选择4个支撑摆臂同时运转  
F5 choose the four supporting arms operate at the same time
- F8操作向下  
F8 operation down

先按一下“F5选择4个支撑摆臂同时运转”，再按“F2操作向上”和“F8操作向下”控制4个支撑摆臂同时上升和下降。  
Firstly press “F5 choose the four supporting arms operate at the same time”, and then press “F2 operation up” and “F8 operation down” to control the four supporting arms up and down at the same time.

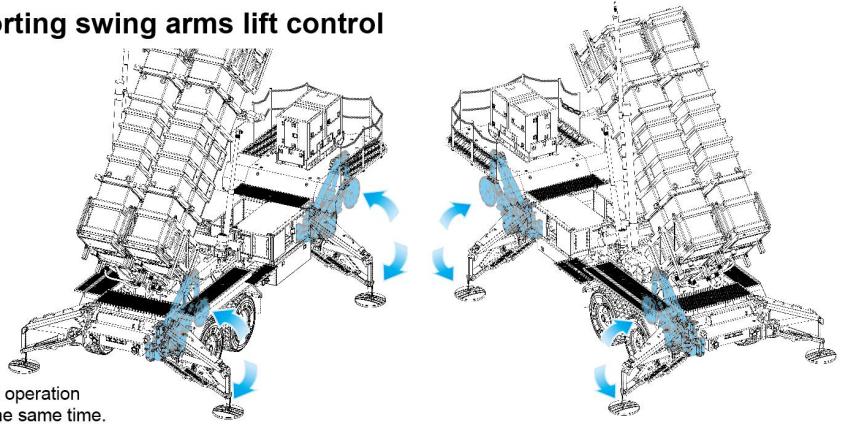

#### 6. 导弹升降控制 Missile lift control

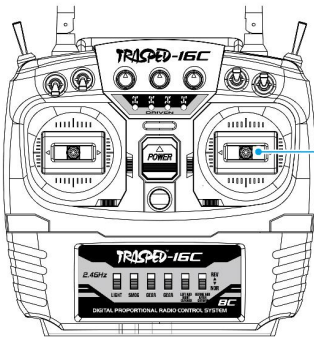

- ↑ 导弹上升 (箭头方向)  
The missile swings up (direction of arrow)
- 停止 Stop
- ↓ 导弹下降 (箭头方向)  
The missile swings down (Direction of arrow)

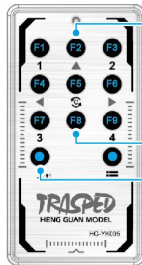

- F2操作向上  
F2 operation up
- F8操作向下  
F8 operation down
- 选择升降  
Choose up and down

先按一下“选择升降”，再按“F2操作向上”和“F8操作向下”控制导弹上升和下降。  
Firstly press “choose up and down”, and then press “F2 operation up” and “F8 operation down” to control the missile up and down.

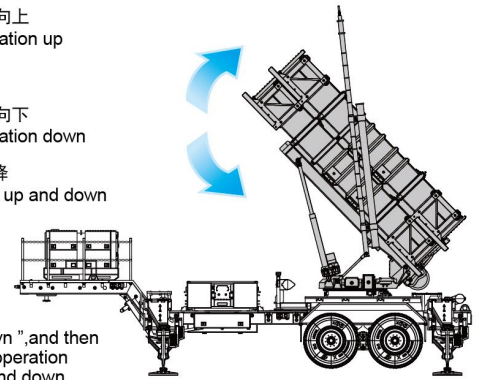

#### 7. 导弹转动控制 Missile rotation control

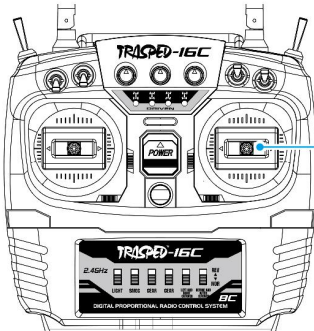

- ← 导弹往左摆动  
The missile swings to the left
- 停止 Stop
- 导弹往右摆动  
The missile swings to the right

- F4主体左旋  
F4 body rotation to the left

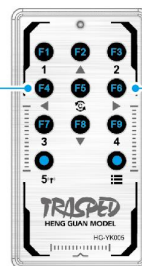

- F6主体右旋  
F6 body rotation to the right

按一下“F4主体左旋”或“F6主体右旋”控制主体左/右旋转。  
Press “F4 body rotation to the left” or “F6 body rotation to the right” to control the missile rotation to the left or right.

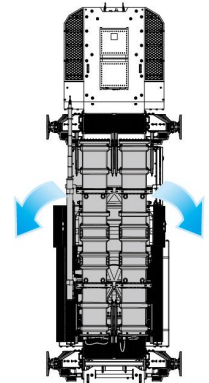



## 模型电池的装配(另购) Assembly of the model battery(Optional)

打开模型电池盖，安装电池。  
Open the battery cover of the model and install the battery.

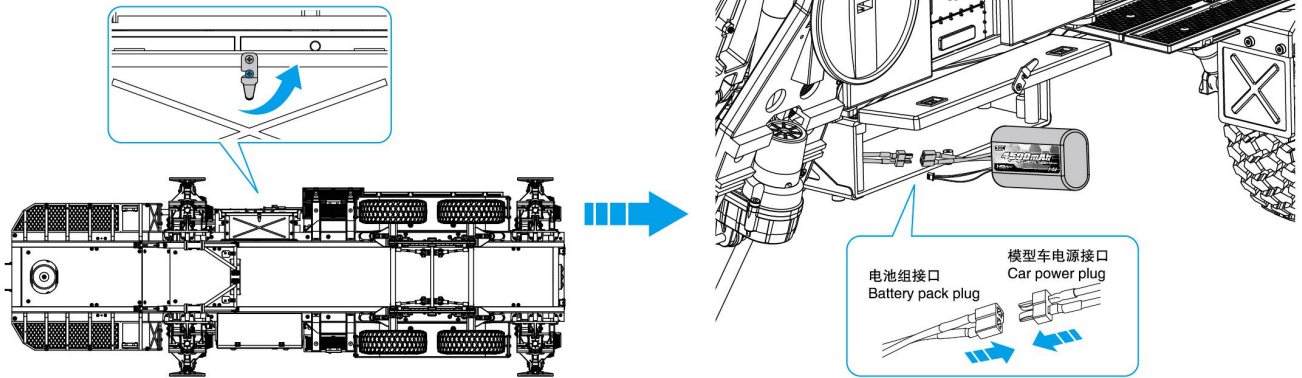

如产品长时间不使用，请立即将电池插头从产品中拔出，取出电池！  
If not to use the product for a long time, please immediately unplug the plug from the product and take out batteries.

## 推荐工具 Tools recommended

产品包装自带工具 Product package include the tools as below

- 内六角螺丝刀 Inner hexagon screwdriver
  - H2.5 2.5mm
  - H2.0 2.0mm
  - H1.5 1.5mm

- 螺丝刀 Screwdriver

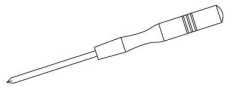

- 开口扳手(小) Open-end spanner (small)



- 十字六角筒(小) Cross hexagon cylinder (small)

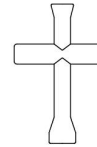

- 内六角扳手 Inner hexagon spanner



- 尼龙扎带 Nylon cable tie

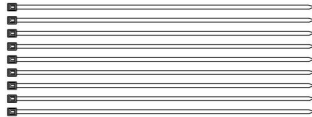

- 钼基润滑脂 Molybdenum base grease



## 自备工具 Self provided tools

- 十字螺丝刀(小) Cross screwdriver (Small)

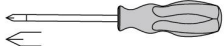

- 一字螺丝刀(小) Straight screwdriver (Small)

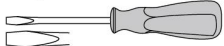

- 剪刀 Scissors

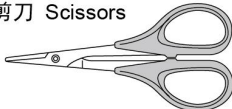

- 橡胶锤 Rubber hammer

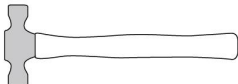

- 游标卡尺 Vernier caliper

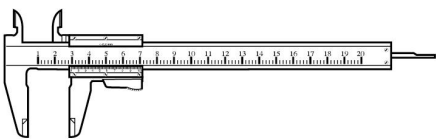

- 剪钳 Side cutters

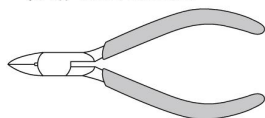

- 模型刀 Modeling knife



- 锉刀 File



- 7mm 开口扳手 Open end wrench



- 长尖嘴钳 Long nose pliers

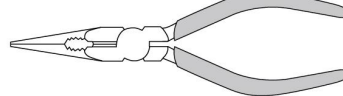

- 镊子 Tweezers



- 手钻 Hand drill

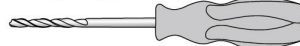

- 塑料粘合剂 Plastic cement

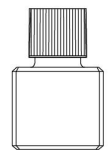

- 瞬间粘合剂 Instant cement

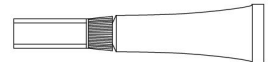

- 润滑油 Lube

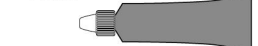

锉刀和软布也有助于安装。  
File and soft cloth will also assist in construction.

# 部件组装图 (Parts assembly diagram)



下列组装步骤中的阴影部分为已经组装完成，说明书提供组装过程，以便于用户深刻了解详细步骤和产品结构，方便日常的维修及保养

The following assembly steps are shaded to indicate that the assembly has been completed. The manual provides the assembly process instructions so that the user can understand the detailed steps and the product.

④-----12  
LS001 TM Ø3x6MM

**1**

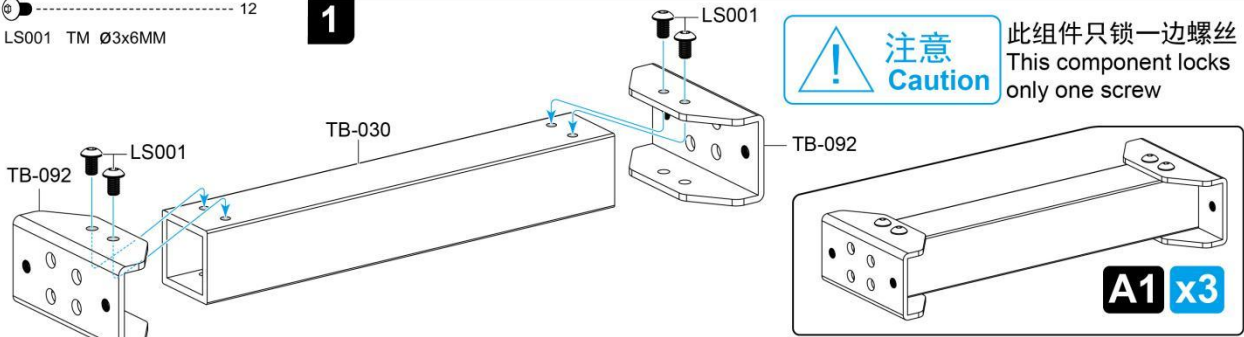

④-----8  
LSKM-312 KM Ø3x12MM

**2**

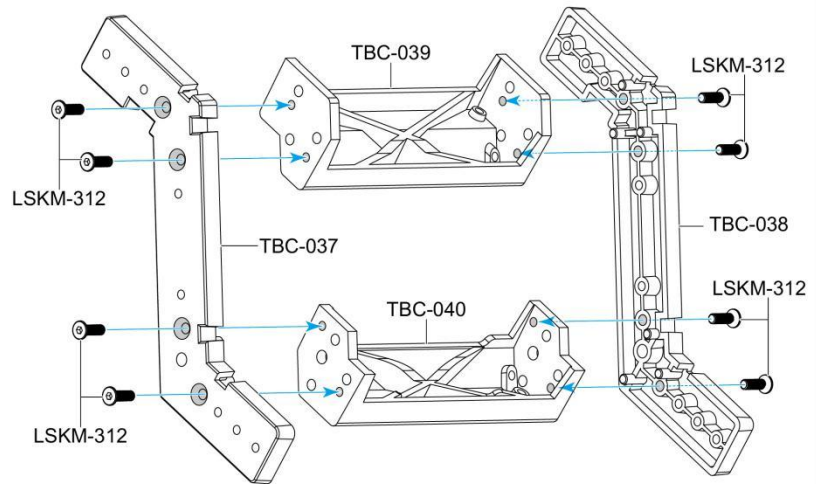
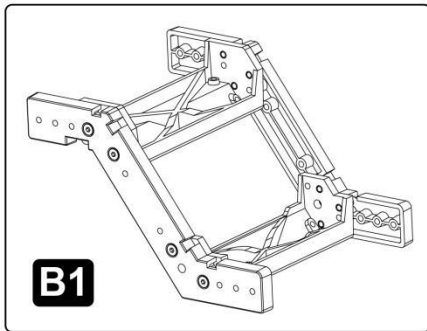

④-----2  
TBC-003 黄色灯罩  
Yellow Lampshade

④-----2  
TBC-002 红色雾灯罩  
Red fog lampshade

**3**

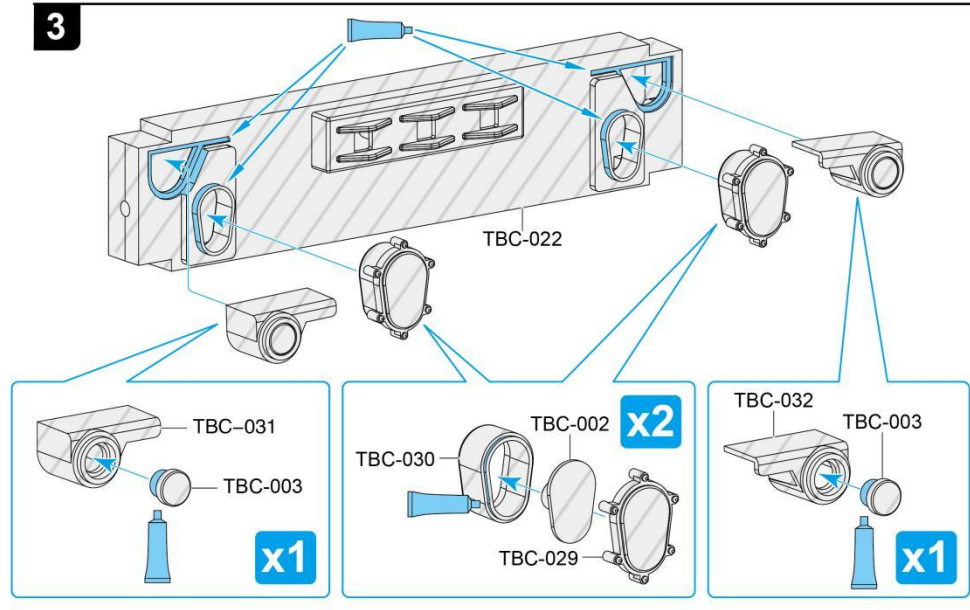

407-LS016 PB Ø2x6MM

**4**

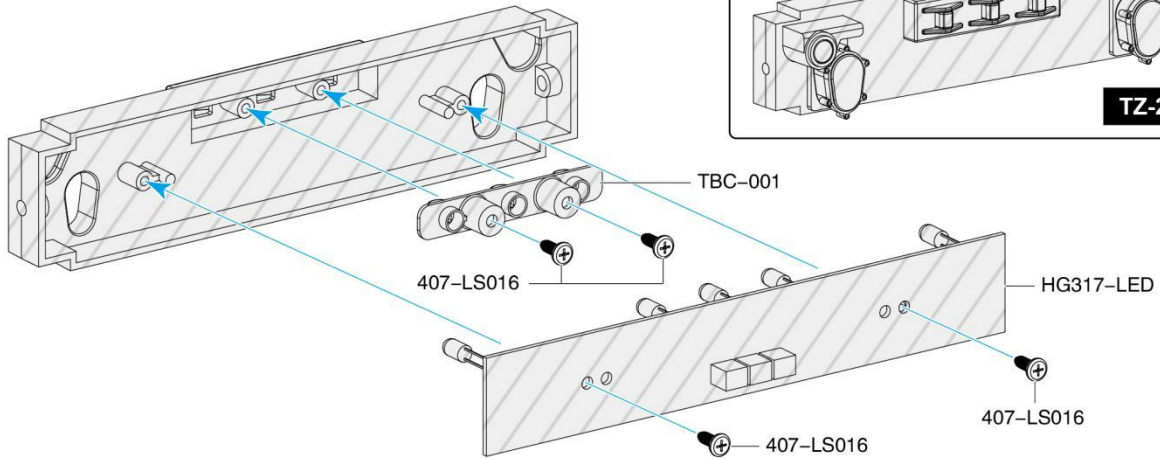

**5**

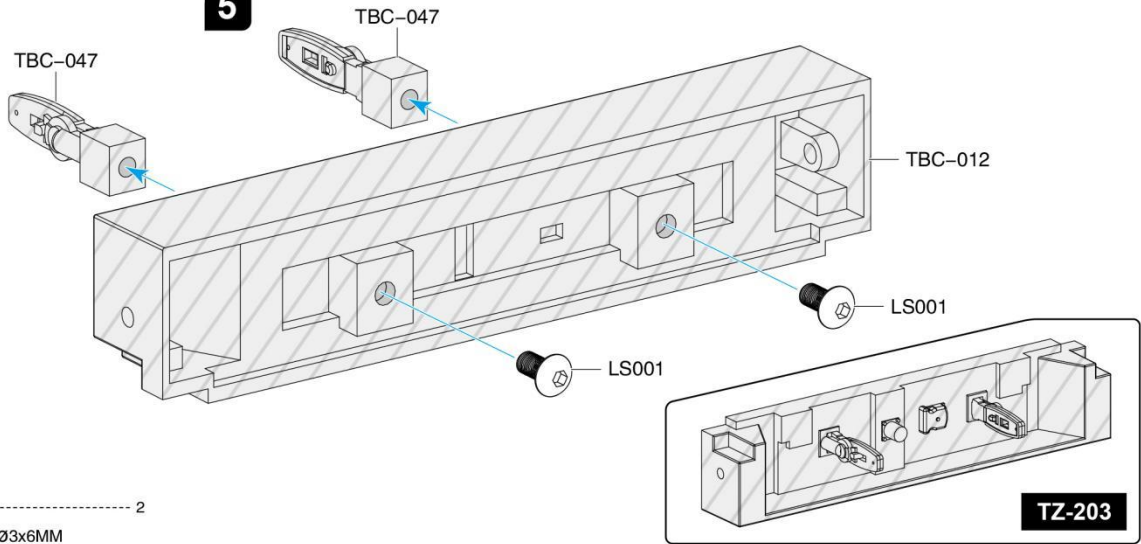

LS001 TM Ø3x6MM

LSKM-318 KM Ø3x18MM

LS023 Ø2mm

LS022 M3

**6**

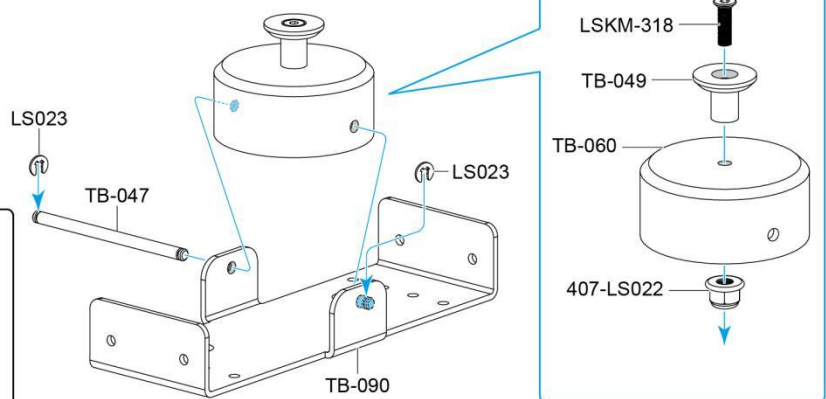
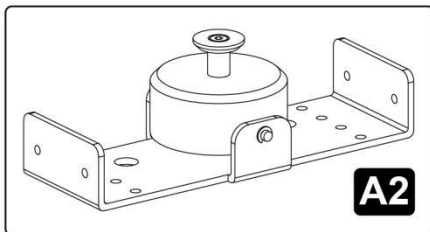



安装A1组件时，锁好螺丝的一边统一向上  
When assemble Part A1, lock the side of  
the screw uniformly up

- P001 KM Ø3x8MM ..... 6
- P002 KM Ø3x6MM ..... 16
- LSKB-38 KB Ø3x8MM ..... 2

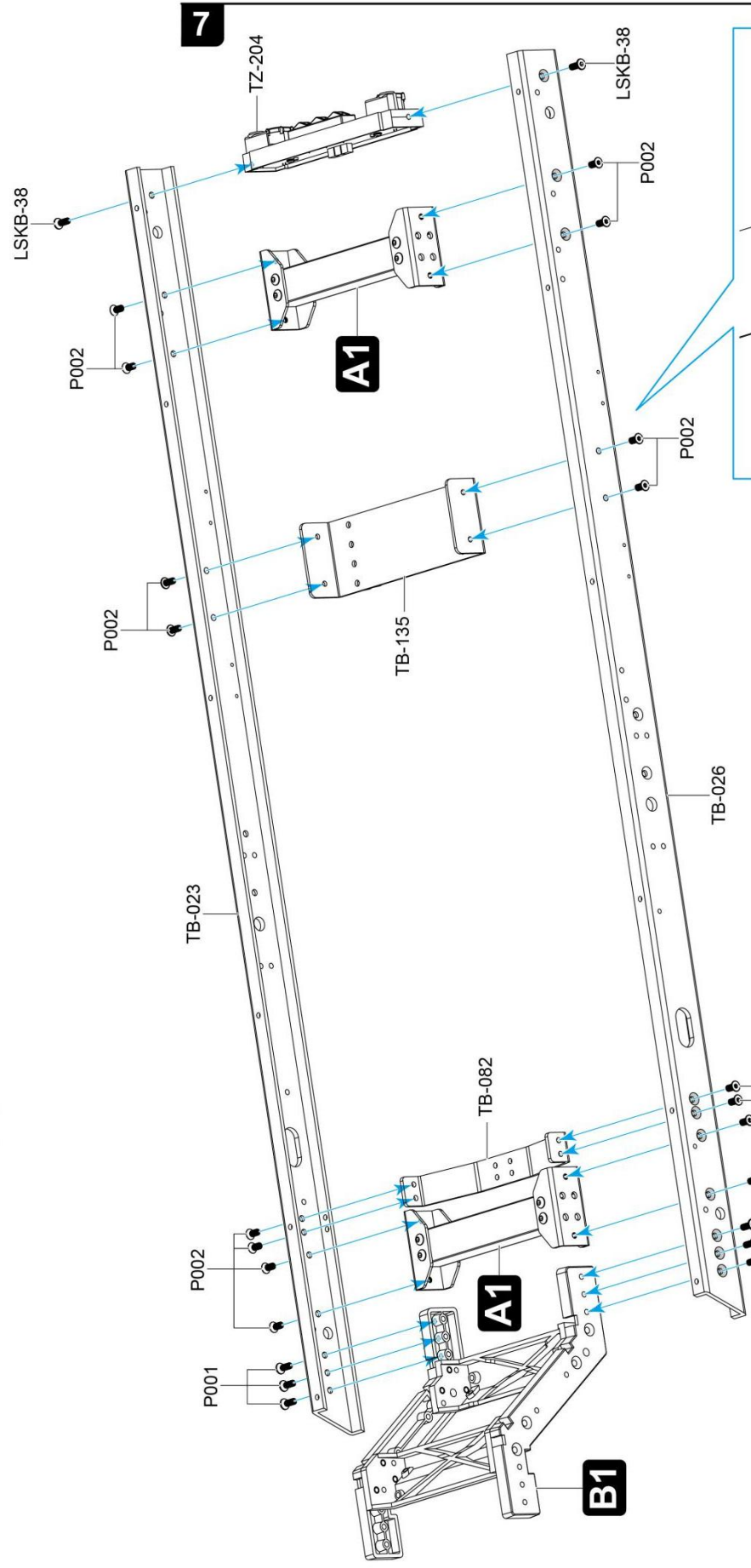

此配件两边的螺丝不能过于用力锁紧，因为该配件处于大梁中间部位。过于锁紧螺丝会导致大梁变形而影响后续步骤的装配，当后面的底板无法安装时，适当将此处两边的螺丝反向松动一圈即可。  
There is no need to lock the screws on both sides of the part too hard, because the part is in the middle of the girder, too tight the screws will lead to the girder out of shape and affect the assembly of the following steps, when the bottom plate behind cannot be installed, appropriate to loosen the screws on both sides of the place one circle.

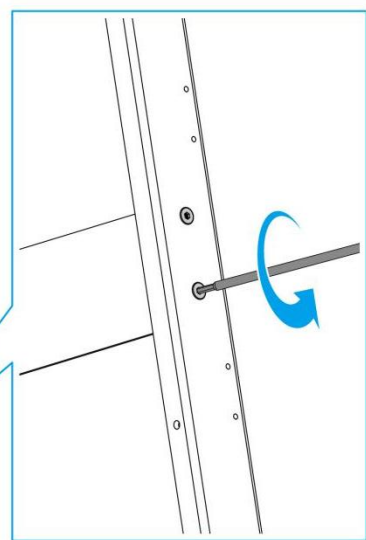

④-----4  
P002 KM Ø3x6MM



此组装步骤要区分  
TB-025(L)和TB-028(R)  
This assembly step is  
to be distinguished  
TB-025(L) and  
TB-028(R)

**8**

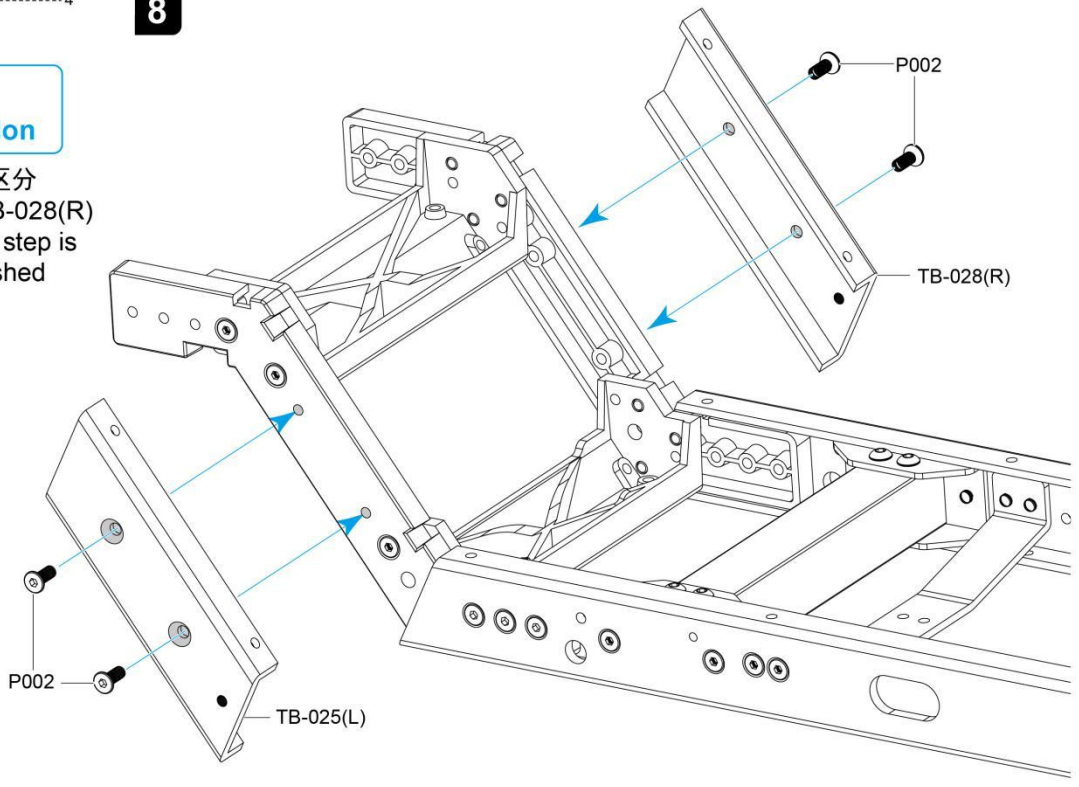

⑤-----6  
P001 KM Ø3x8MM

④-----8  
P002 KM Ø3x6MM

②-----2  
LSKB-38 KB Ø3x8MM

**9**

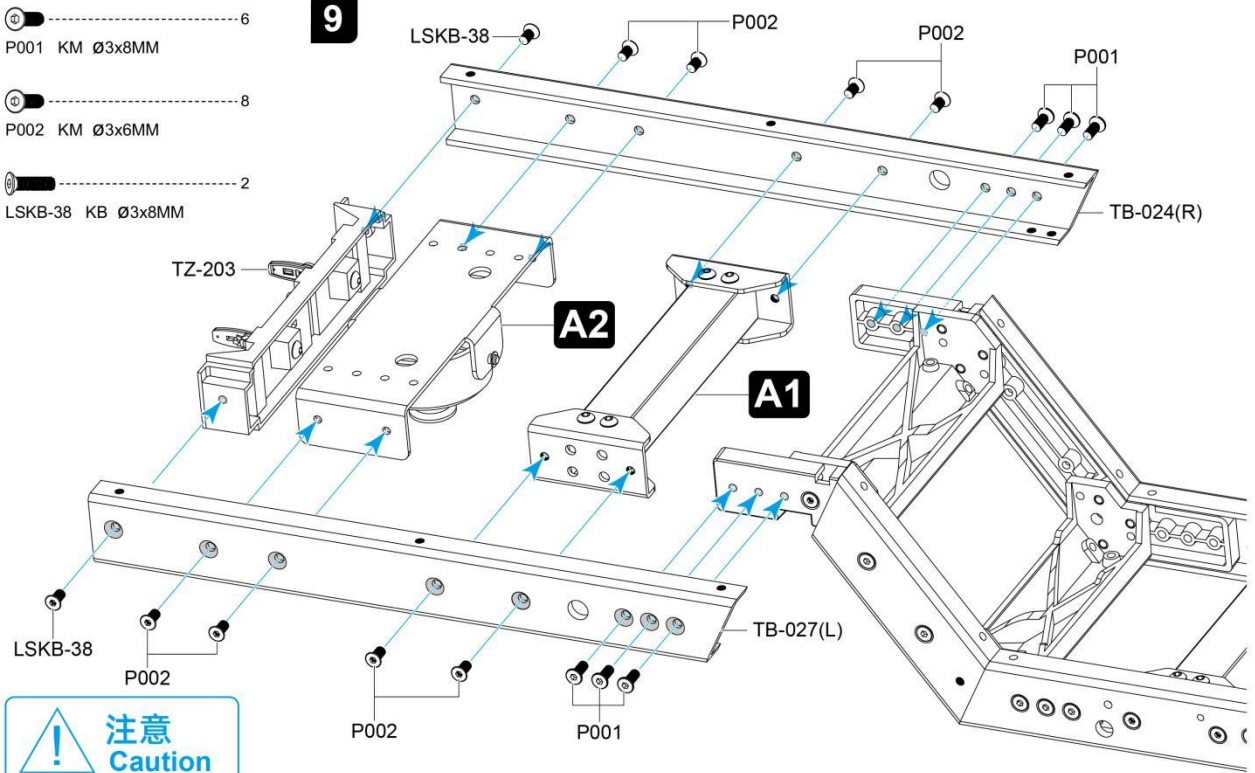

1. 此组装步骤要区分TB-027(L)和TB-024(R)。  
This assembly step is to be distinguished  
TB-027(L) and TB-024(R)

2. 安装A1组件时, 锁好螺丝的一边统一向上。  
When assemble part A1, lock the side of the  
screw uniformly up.

LSKB-38

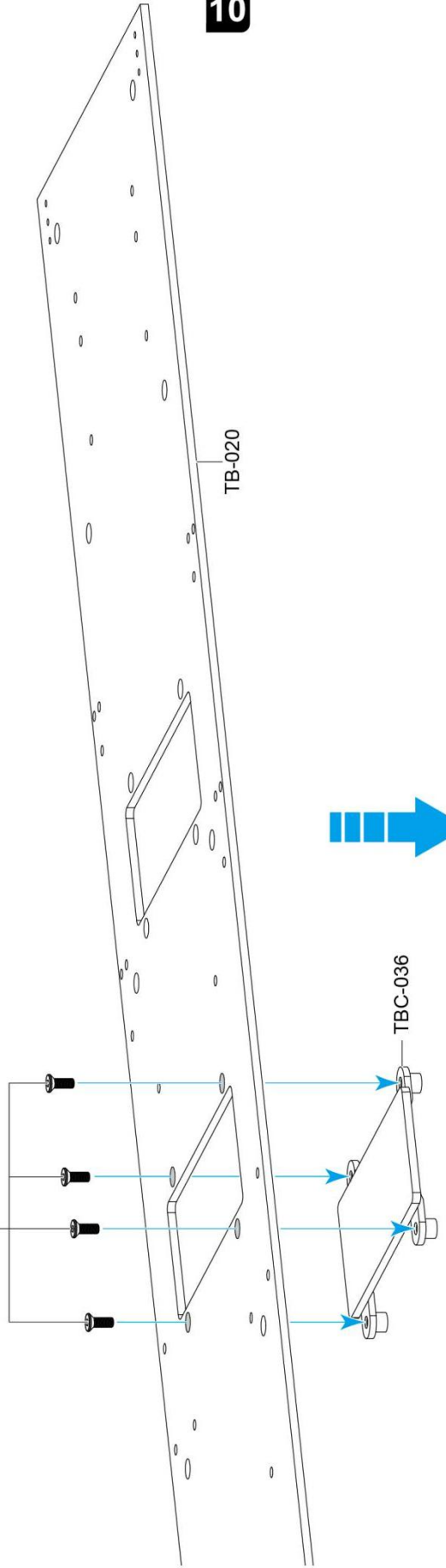

10

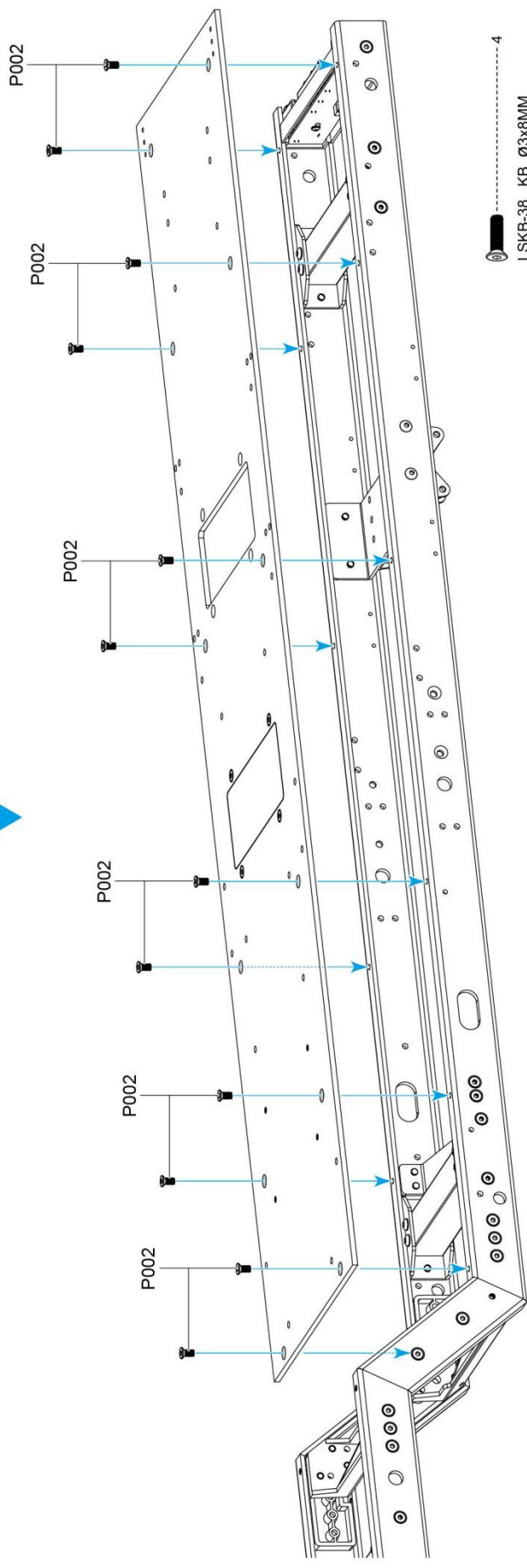

- LSKB-38 KB Ø3x8MM .....4
- P002 KM Ø3x6MM .....12

④ ..... 4  
P002 KM Ø3x6MM

11

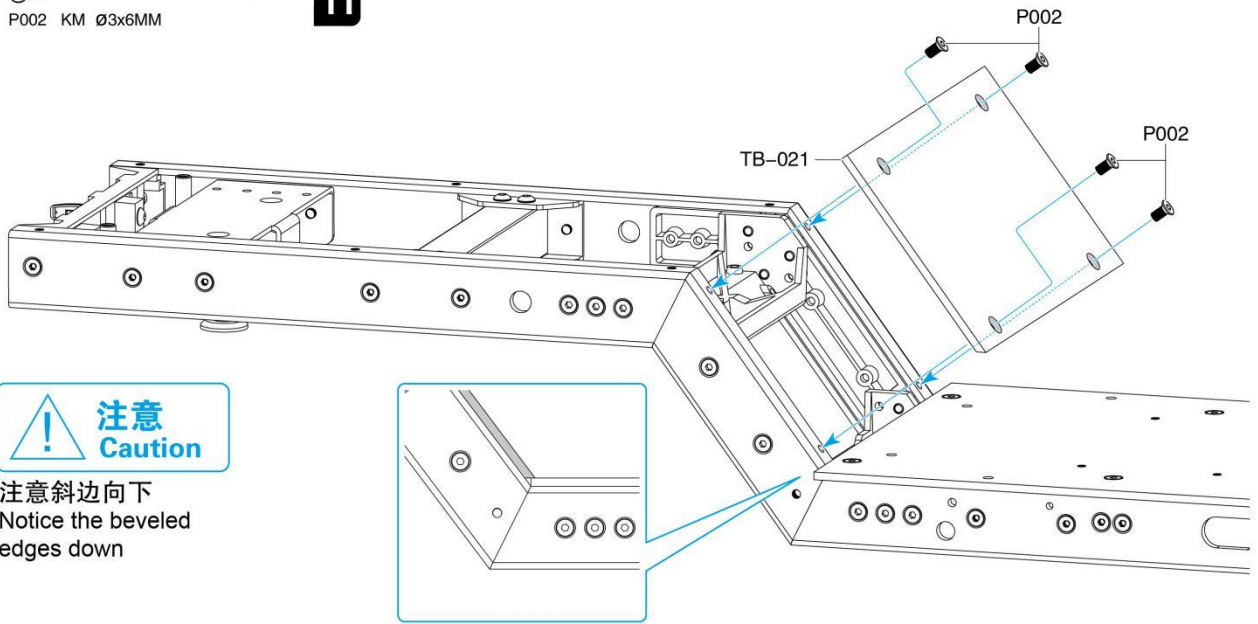

注意斜边向下  
Notice the beveled  
edges down

④ ..... 6  
P002 KM Ø3x6MM

12

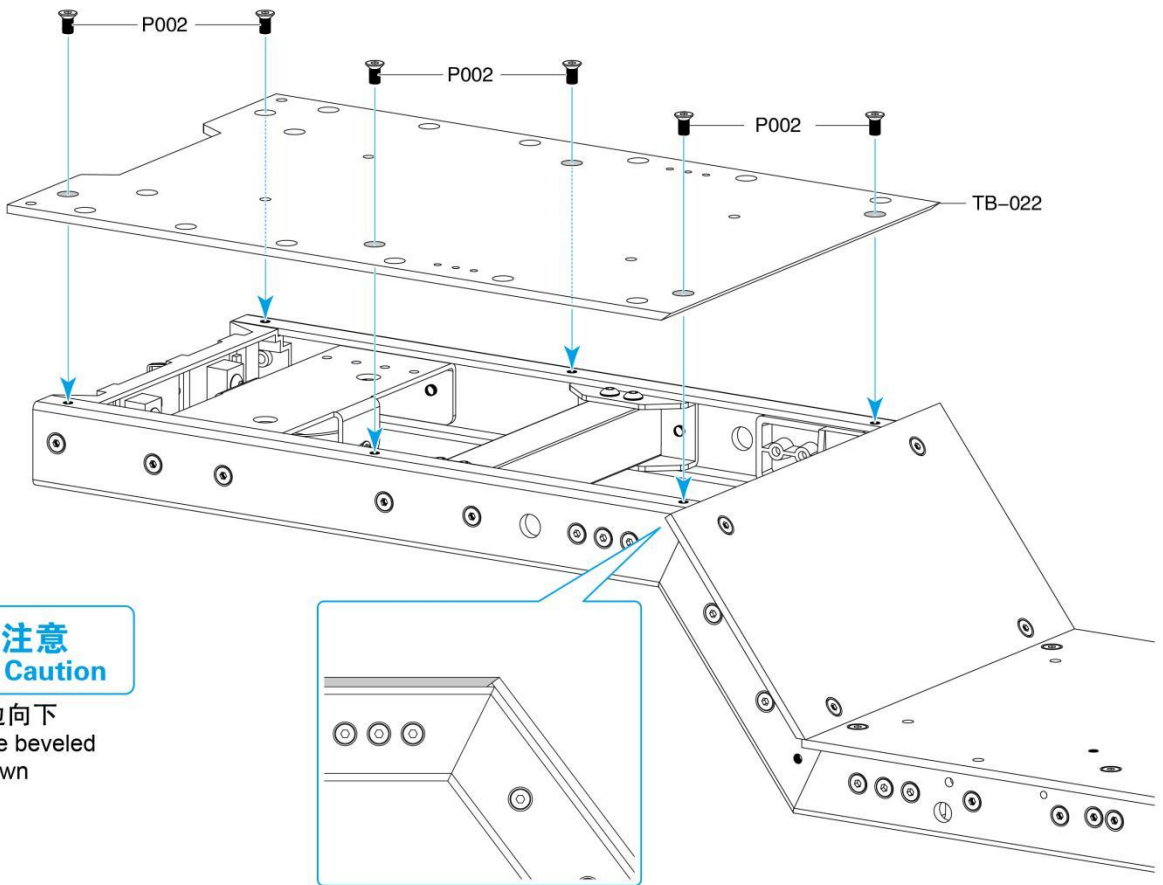

注意斜边向下  
Notice the beveled  
edges down

 ..... 2  
P002 KM Ø3x6MM

 ..... 2  
TB-1521 Ø5x23.5MM

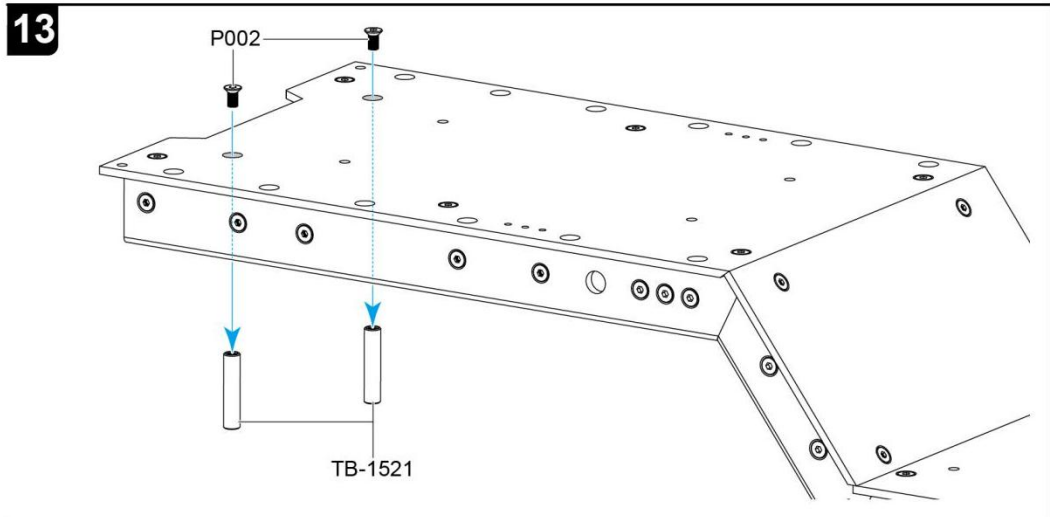

 ..... 4  
LS100 TM Ø2x6MM

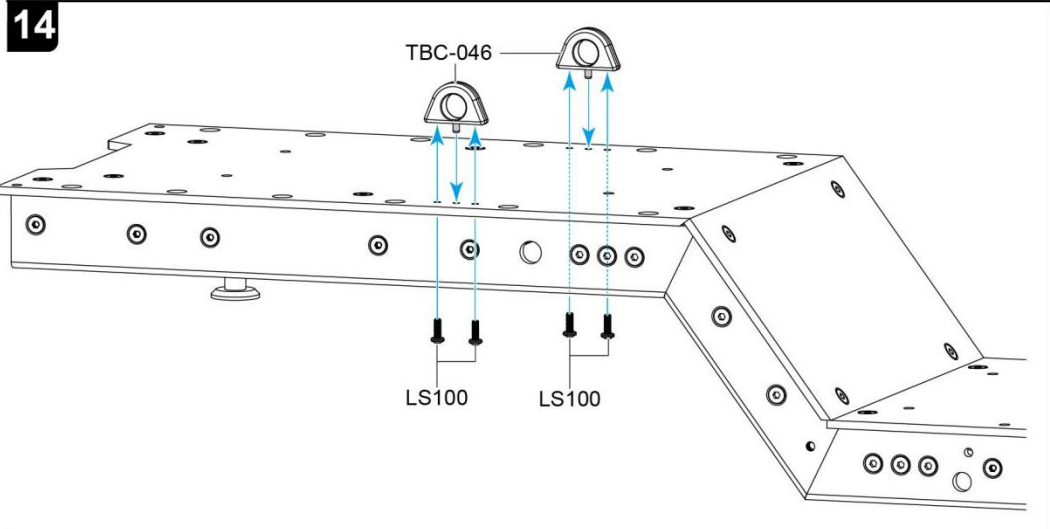

 ..... 2  
LSTB38 TB Ø3x8MM

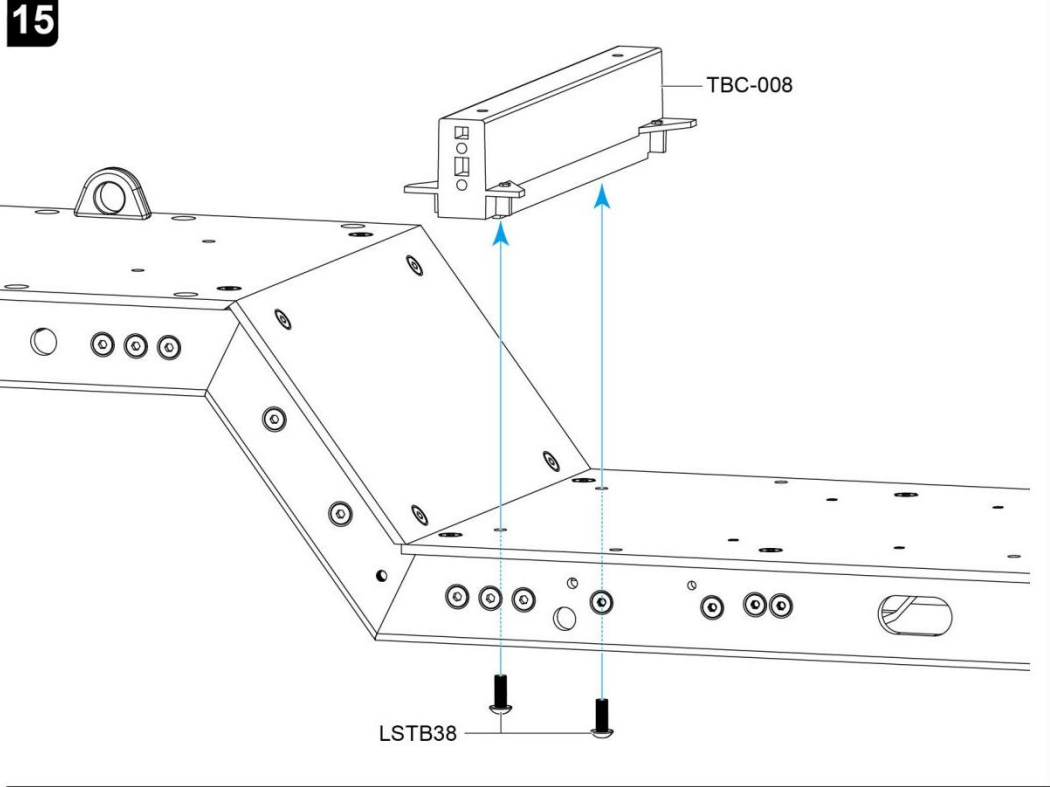



16

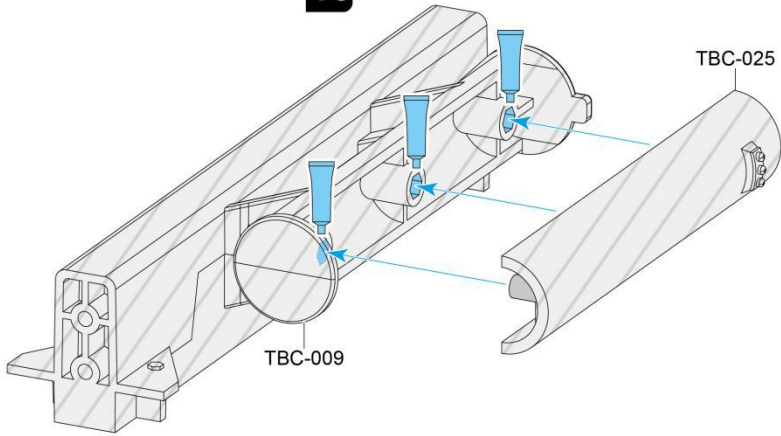

此配件出厂时已组装完成，组装图只是提供组装过程。

This accessory was assembled at the factory, and the assembly diagram simply provides the assembly process.

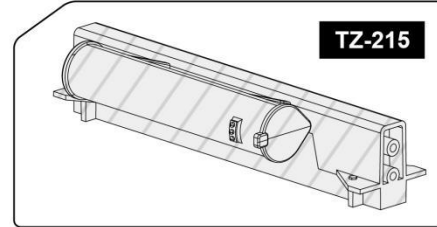

LS100 TM Ø2x6MM 4

17

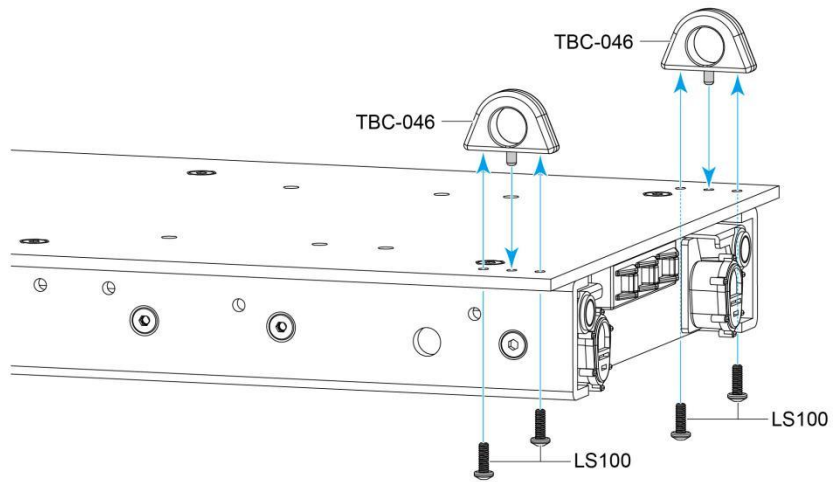

LSTB38 TB Ø3x8MM 2

18

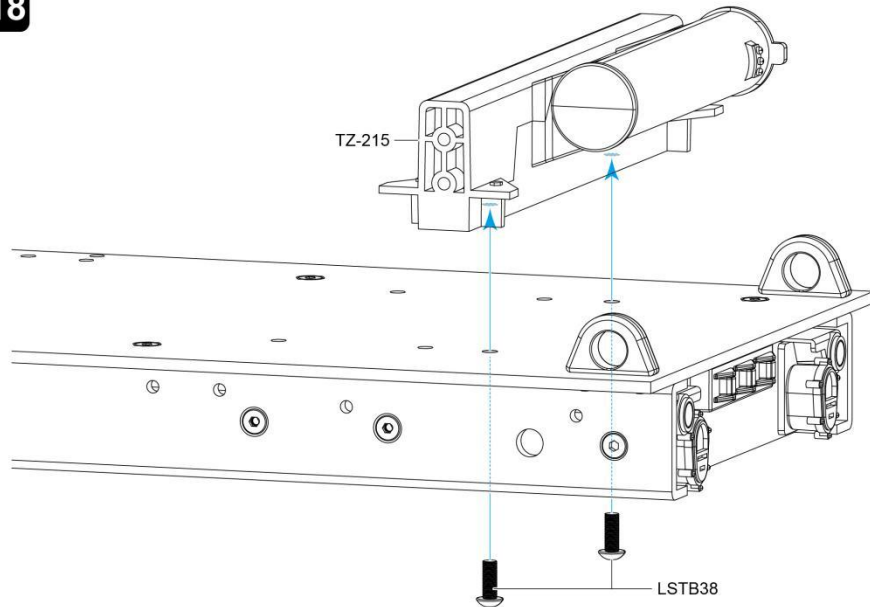

LS001 TM Ø3x6MM 12

19

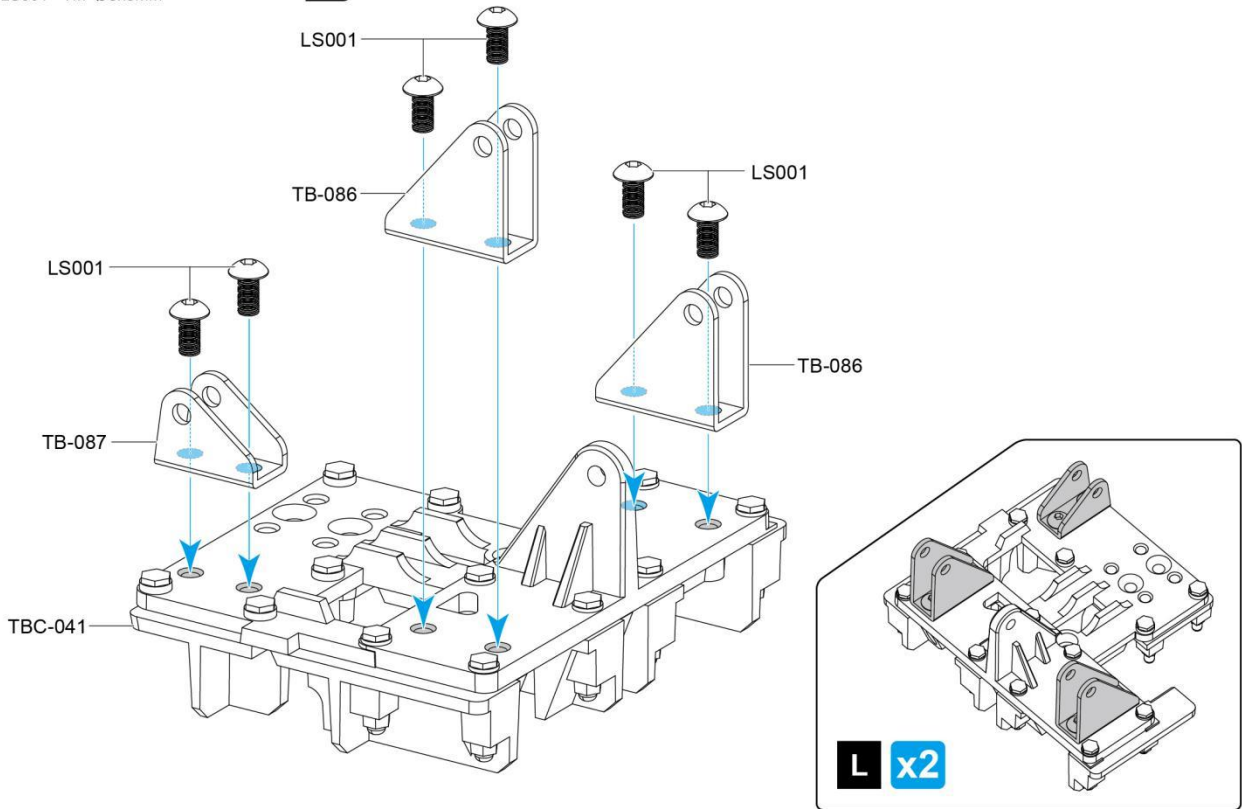

LS001 TM Ø3x6MM 12

20

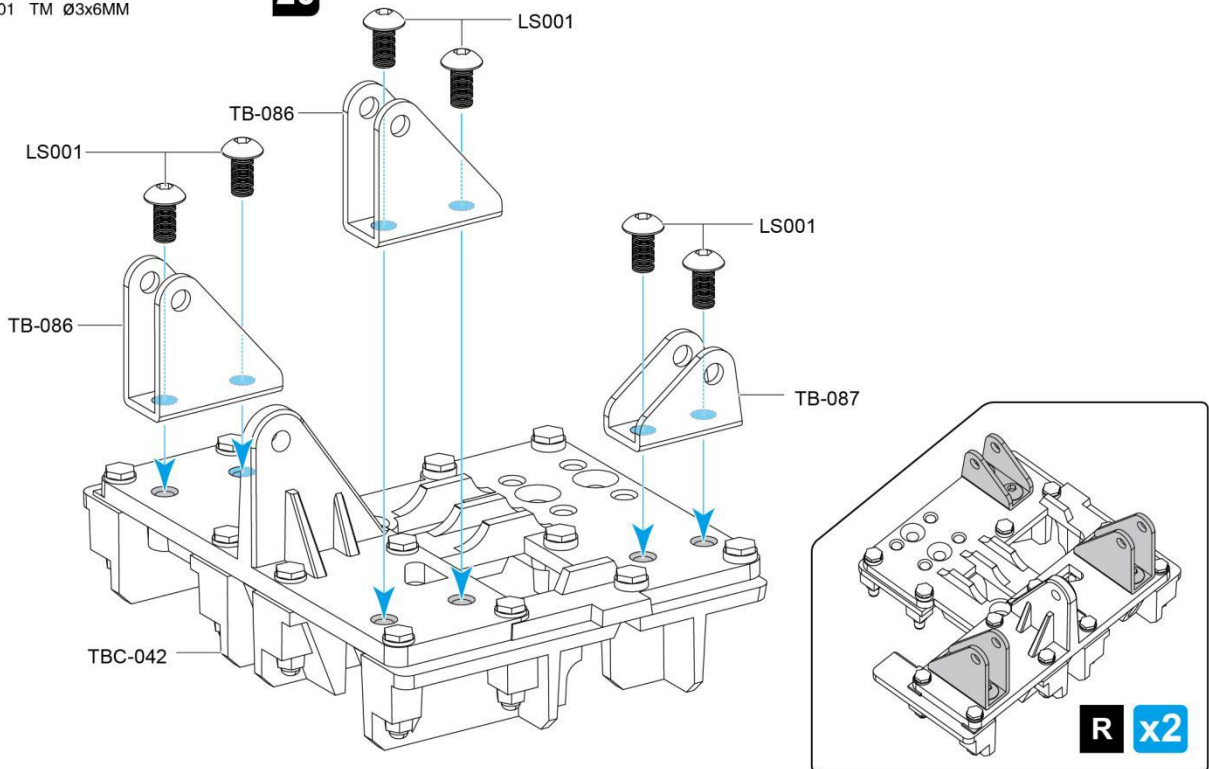



此处配件安装需注意区分 **L** 和 **R**，以及前后安装方向。

The installation of accessories here requires a distinction between **L** and **R**, as well as the direction of the front and rear installations.

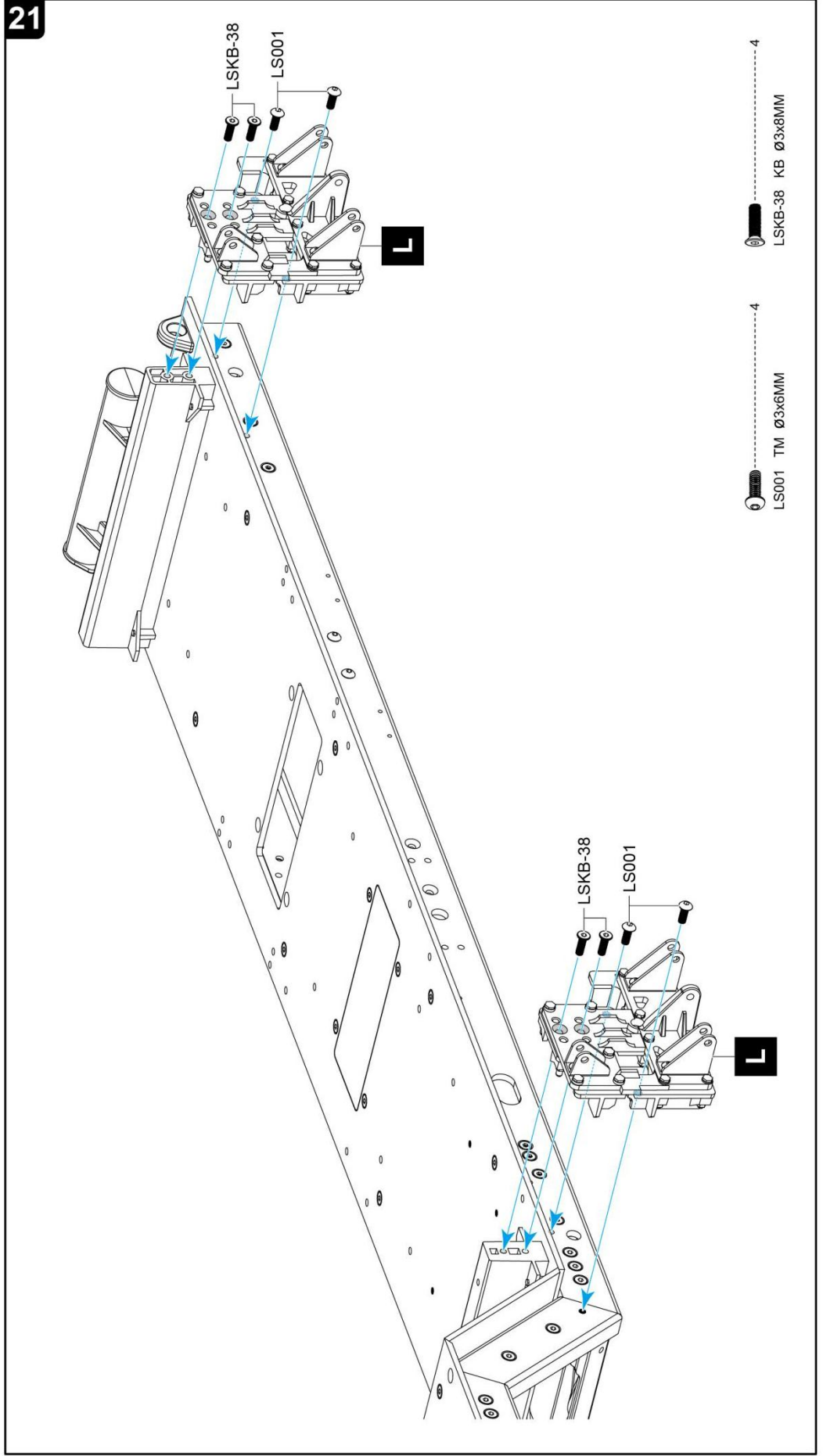



此处配件安装需注意区分 **L** 和 **R**。  
The installation of accessories here  
requires a distinction between **L**  
and **R**.

22

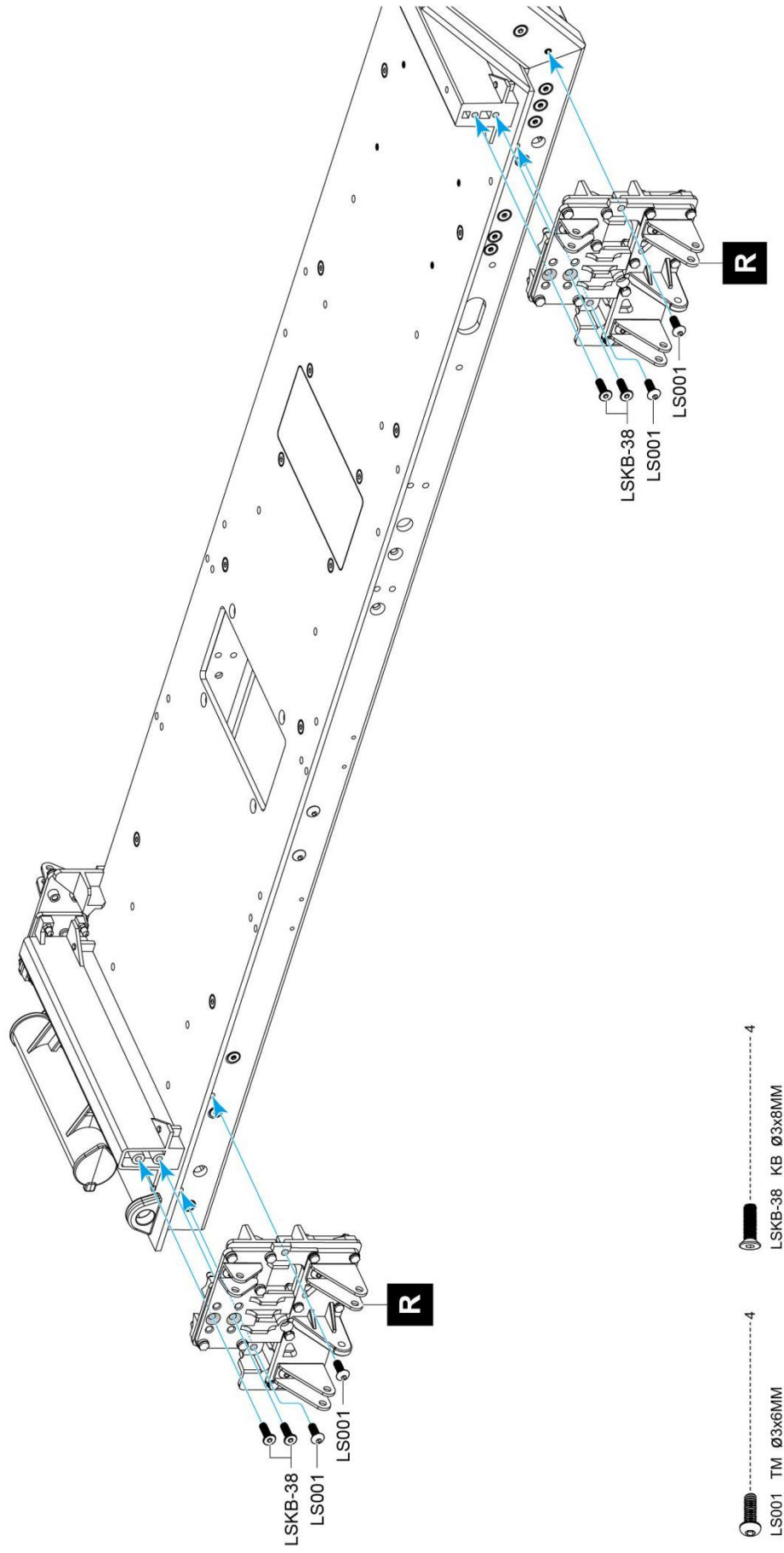

LS001 TM Ø3x6MM

23

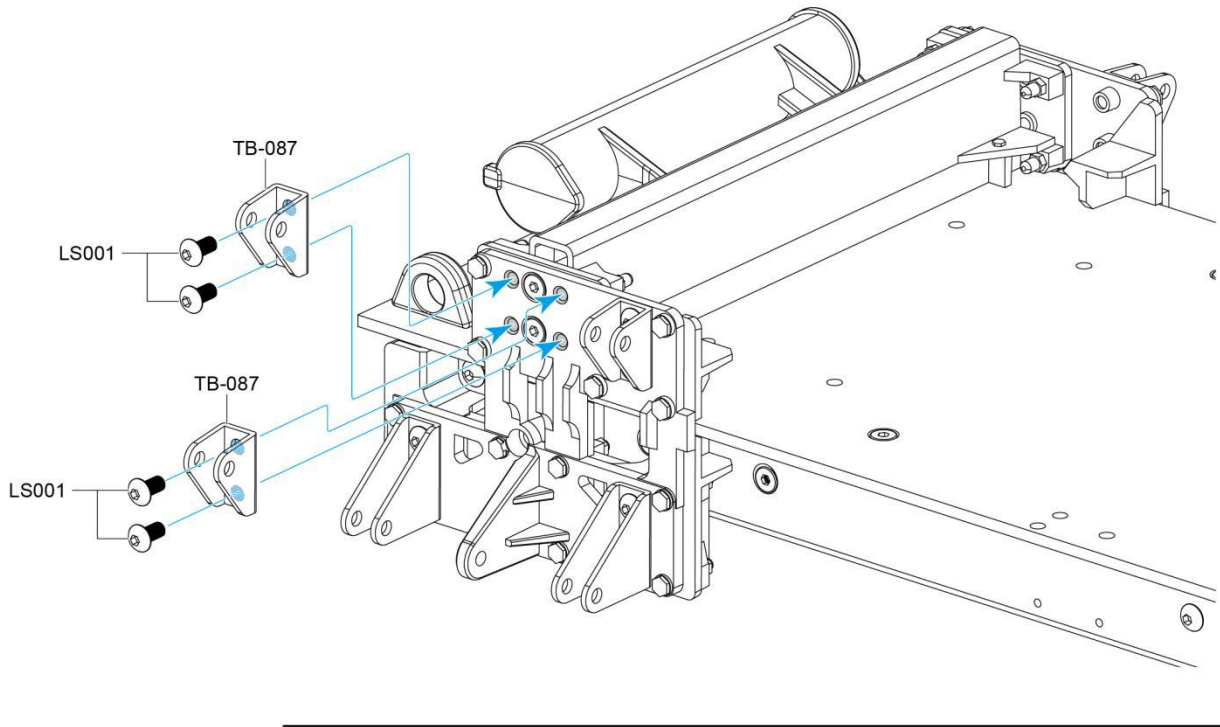

24

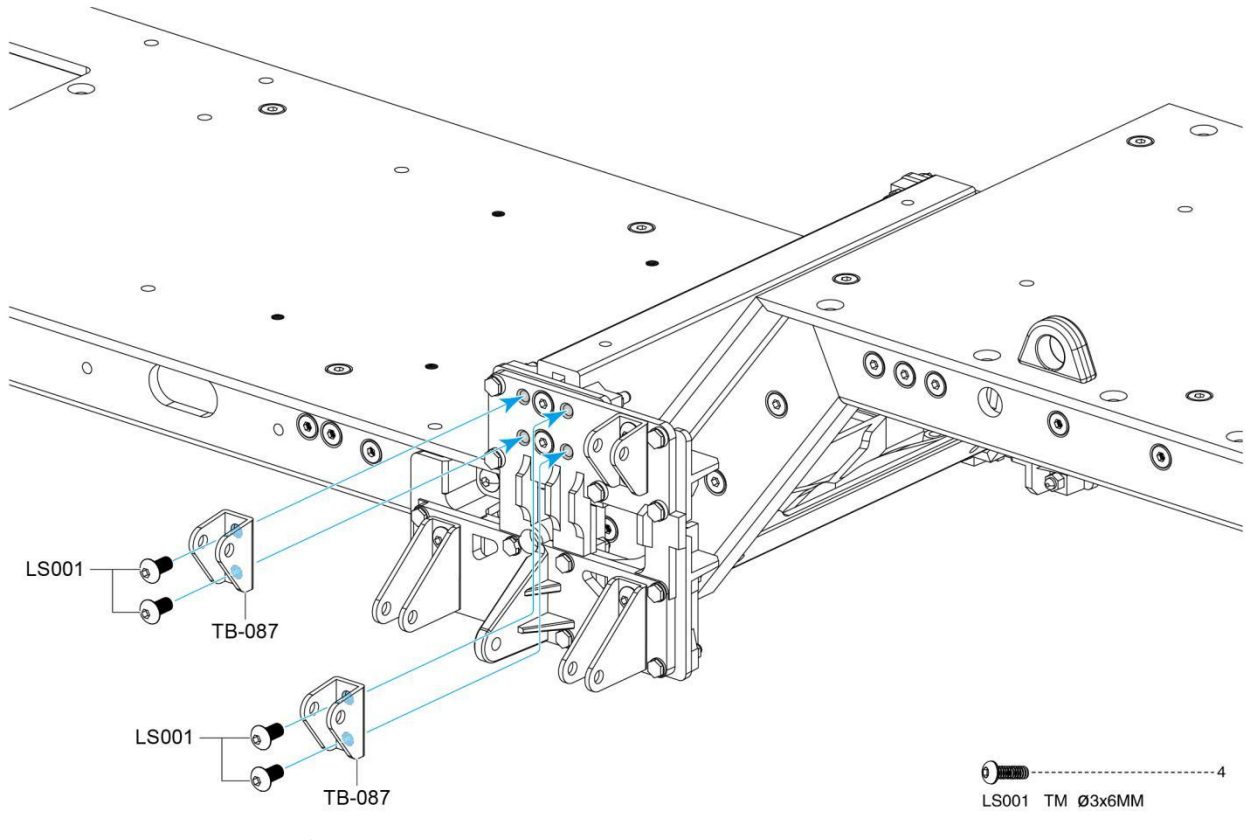

LS001 TM Ø3x6MM

LS001 TM Ø3x6MM

25

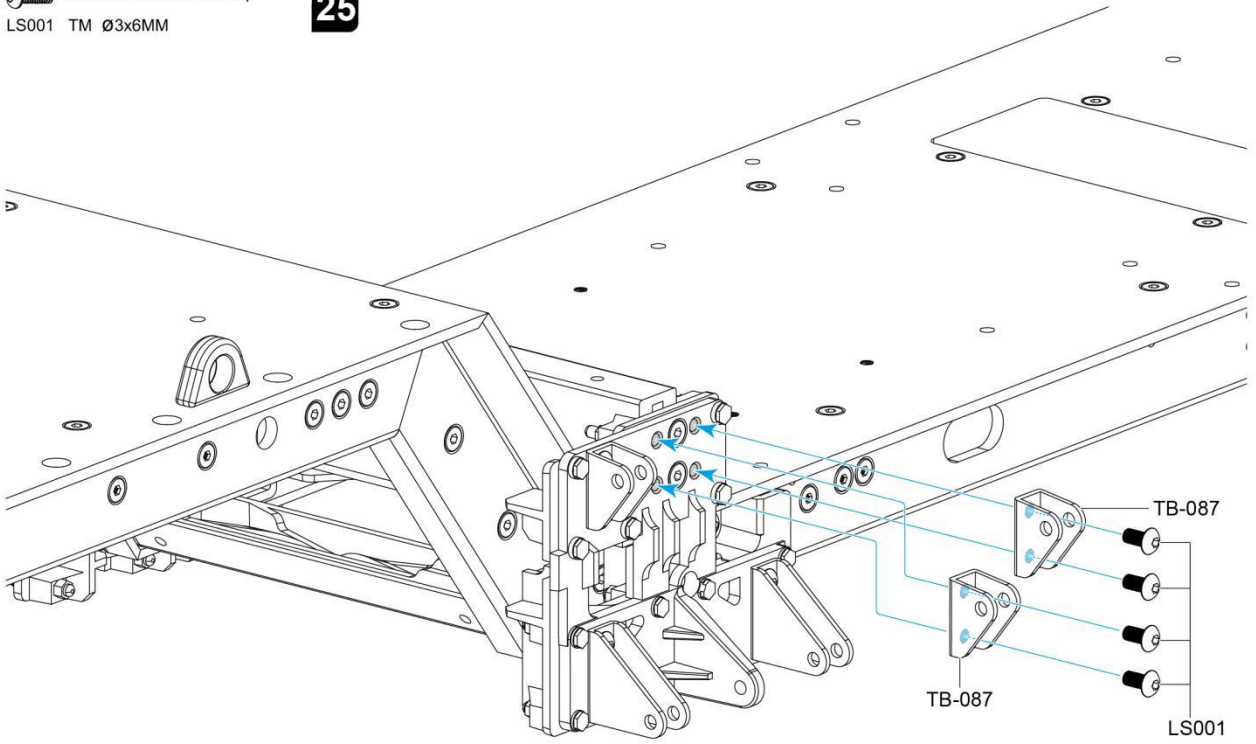

LS001 TM Ø3x6MM

26

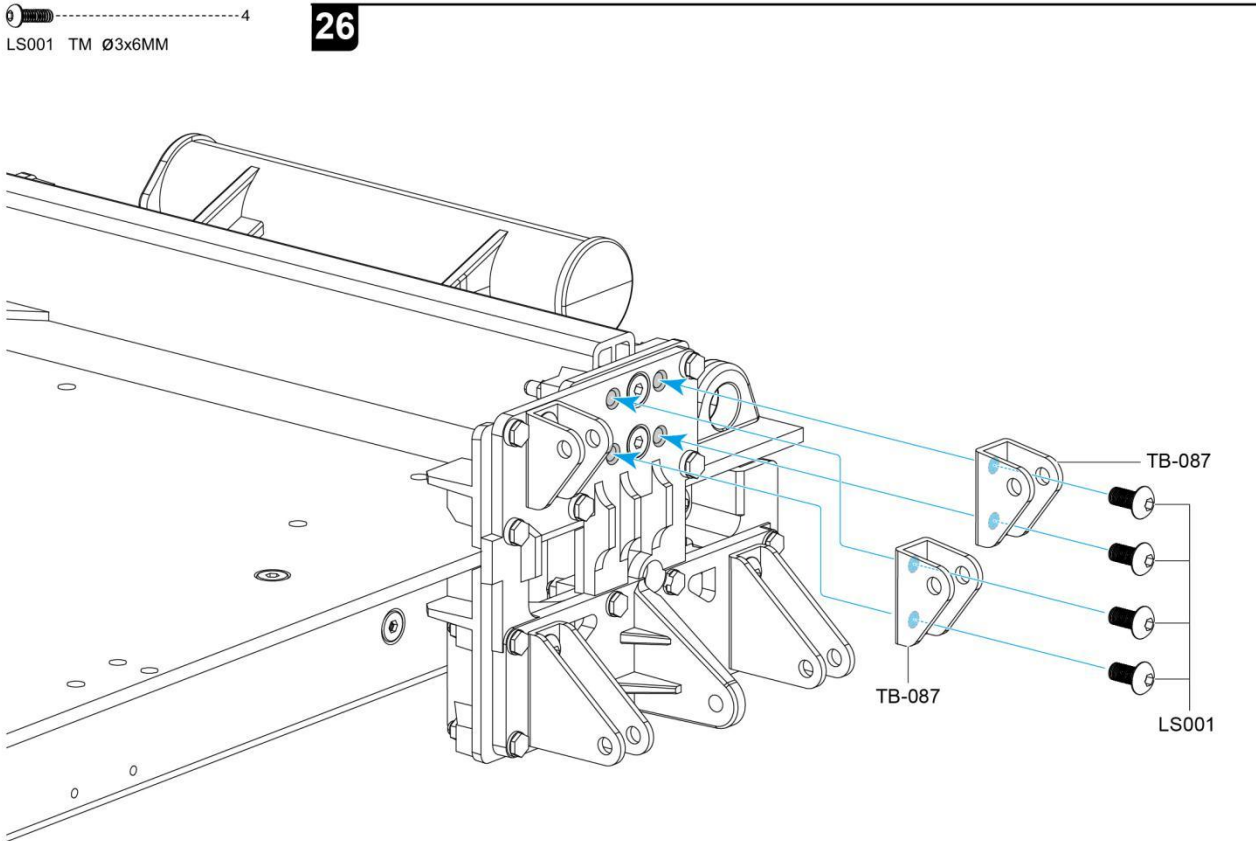

LSKB-05 KB Ø2x5MM 6

27

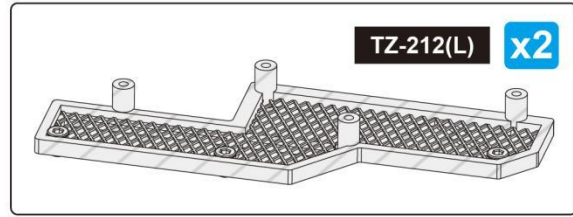
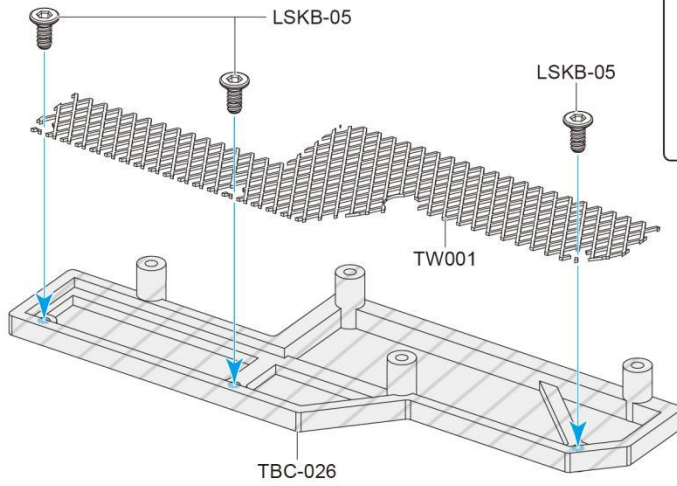



此配件出厂时已组装完成，组装图只是提供组装过程。  
This accessory was assembled at the factory, and the assembly diagram simply provides the assembly process.

P544 KB Ø2x6MM 8

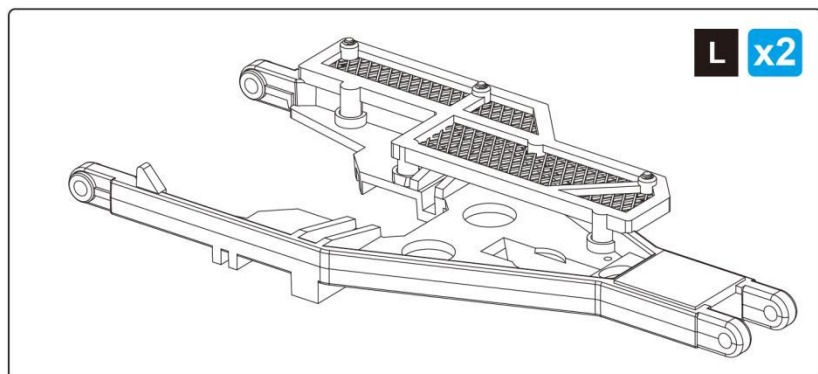
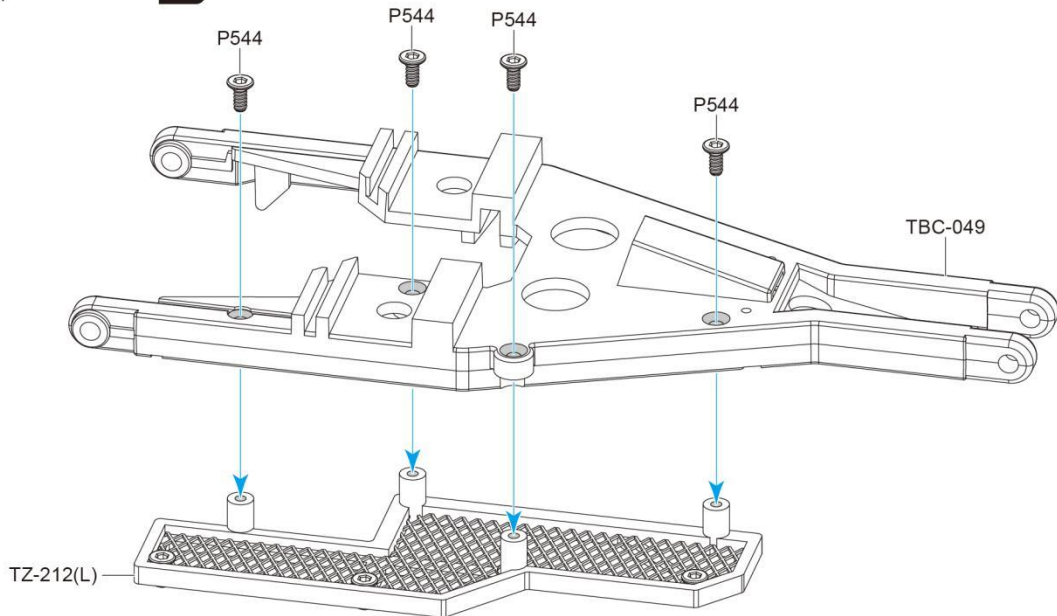
28



-  8
-  8
-  4

**29**



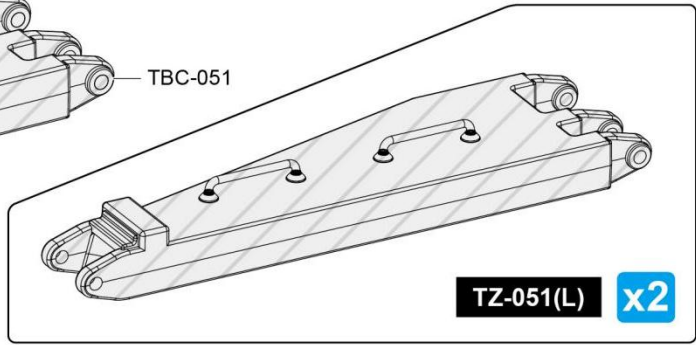
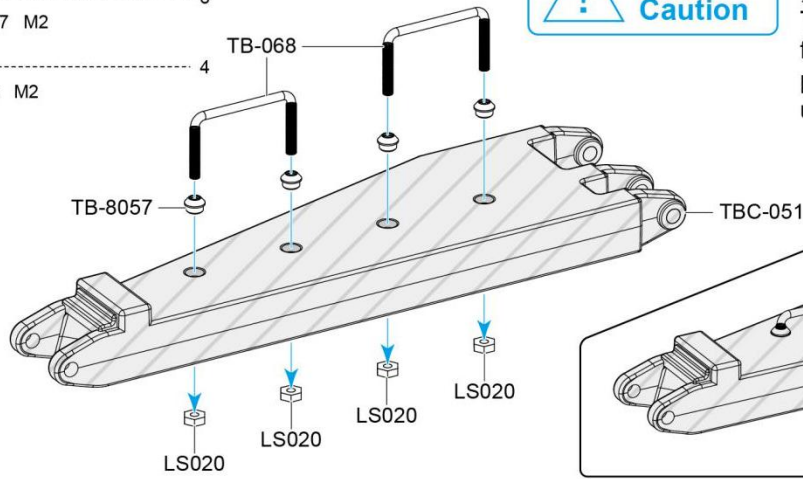

此配件出厂时已组装完成，组装图只是提供组装过程，可用于维护配件。  
This accessory was assembled at the factory, and the assembly diagram simply provides the assembly process, can be used to maintain accessories.

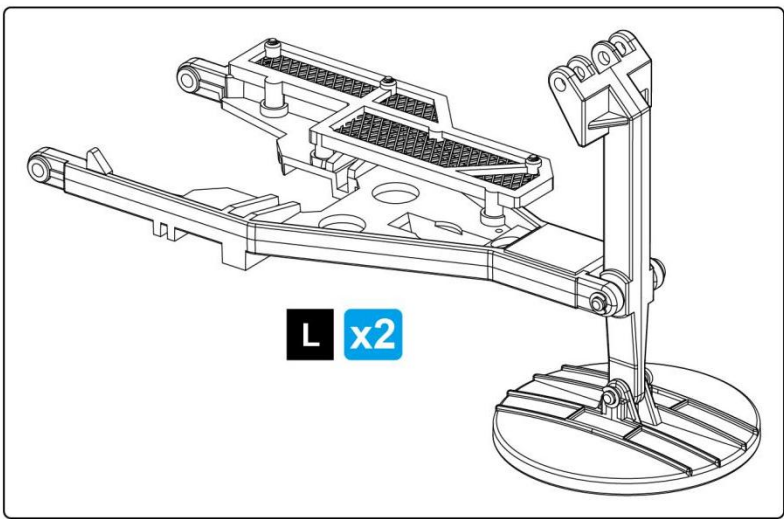
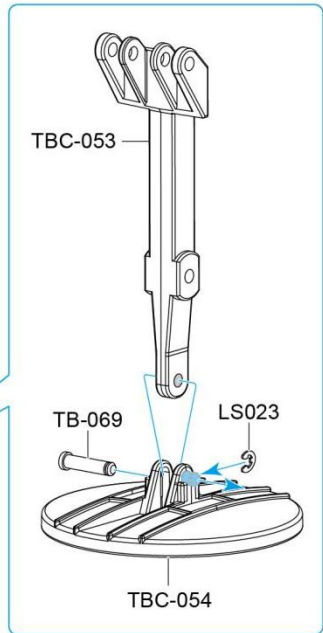
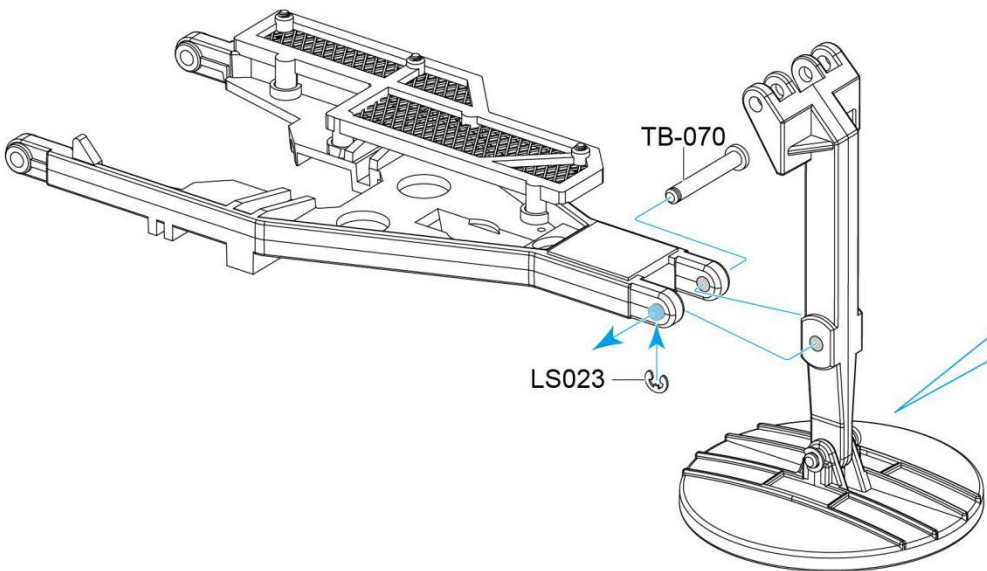

**30**



-  4
-  2
-  2



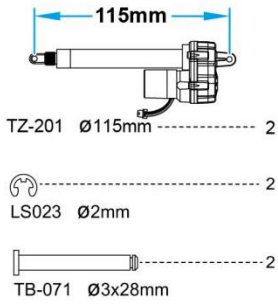

**31**

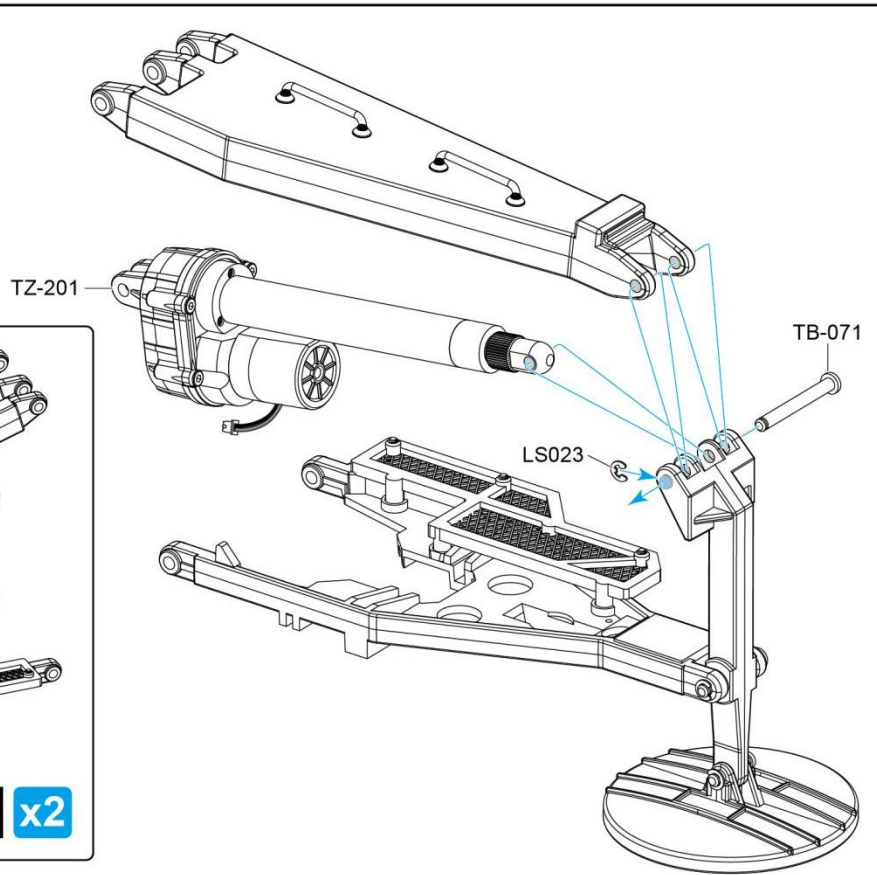
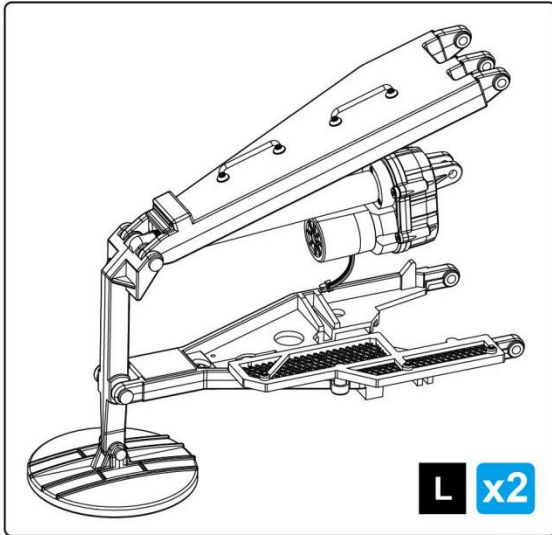

**32** 左前支撑脚的安装 1 Left front supporting leg installation 1

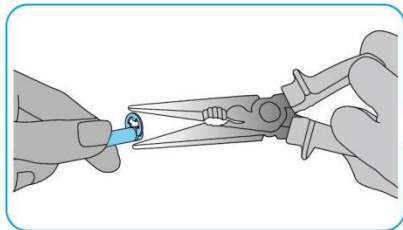

先将卡簧卡住定位轴一头，待整体支撑臂安装无误后，再来卡另一头卡簧。  
First the reed stuck in the positioning shaft head, until the overall support arm installation is correct, and then card the other end of the reed.

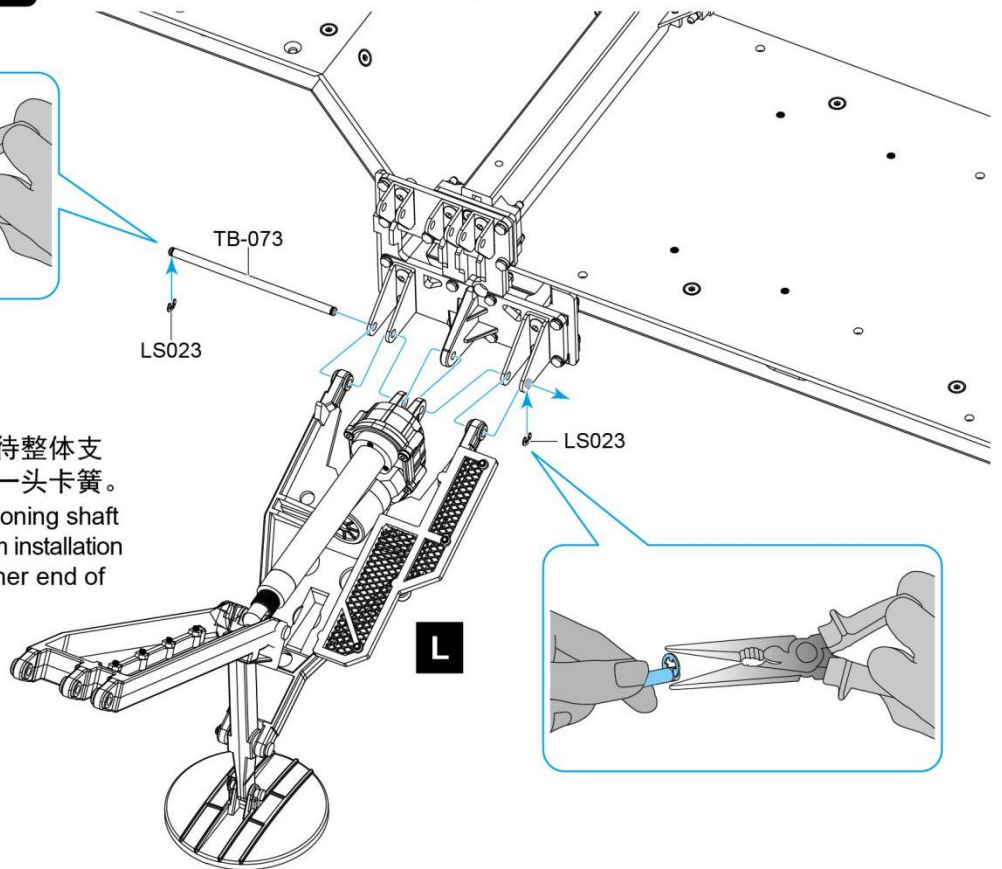
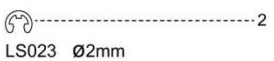

LS023  $\varnothing$ 2mm

TB-072 3x45.5mm

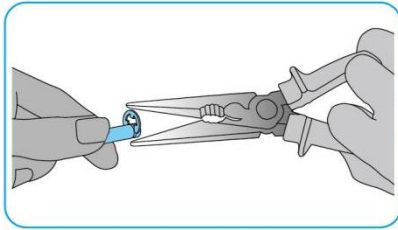

先将卡簧卡住定位轴一头，待整体支撑臂安装无误后，再来卡另一头卡簧。  
First the reed stuck in the positioning shaft head, until the overall support arm installation is correct, and then card the other end of the reed.

### 33 左前支撑脚的安装2 Left front supporting leg installation 2

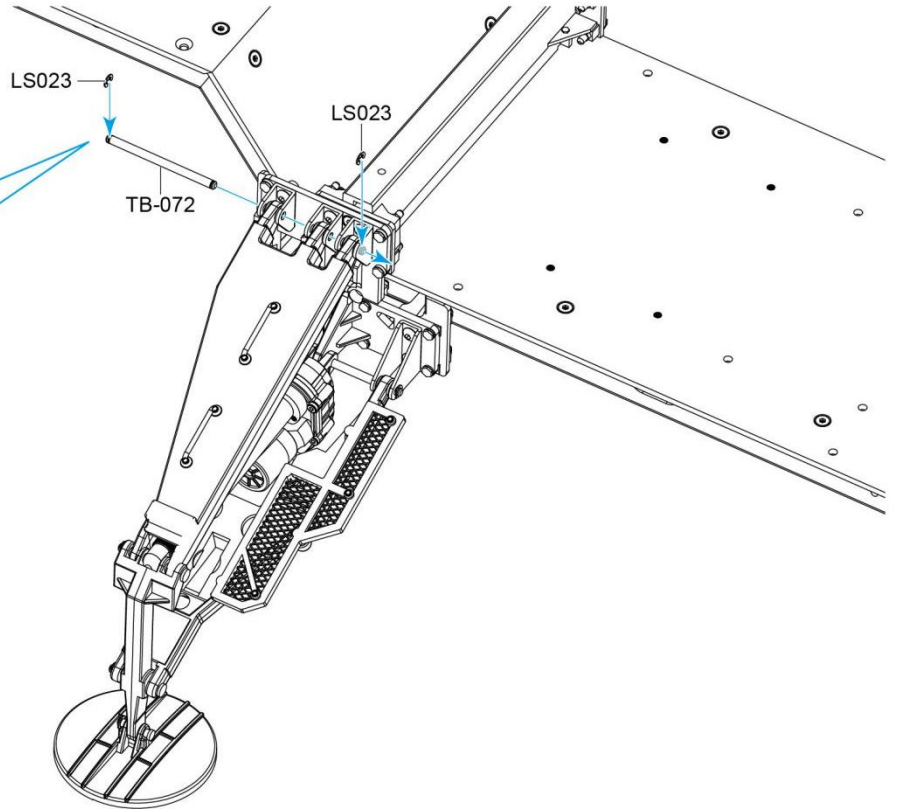

### 34 左后支撑脚的安装1 Left rear supporting leg installation 1

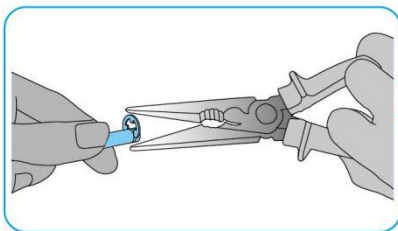

先将卡簧卡住定位轴一头，待整体支撑臂安装无误后，再来卡另一头卡簧。  
First the reed stuck in the positioning shaft head, until the overall support arm installation is correct, and then card the other end of the reed.

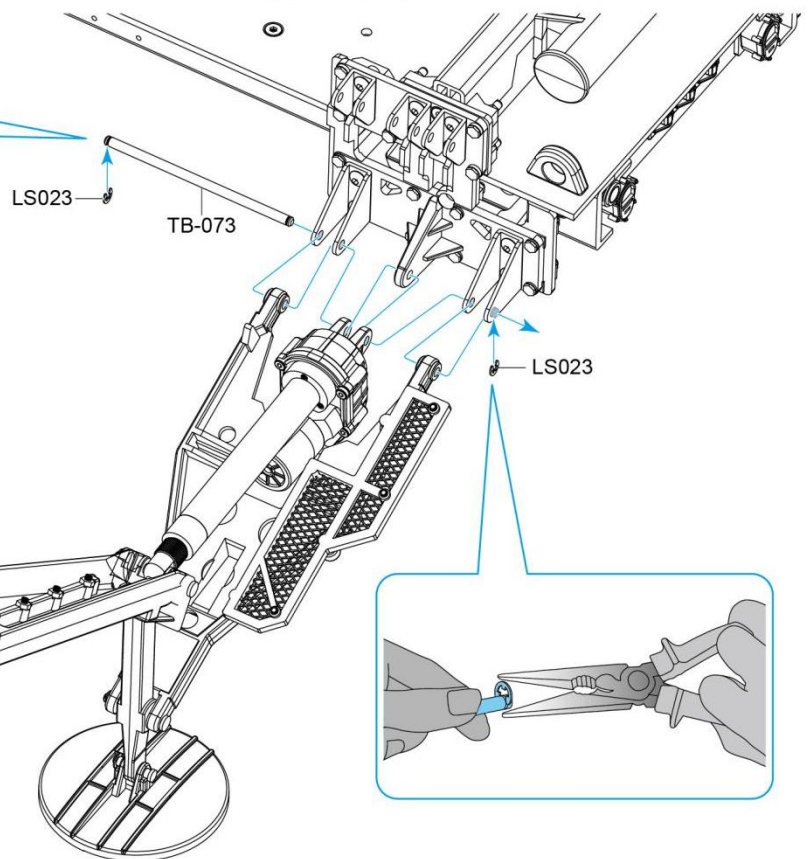

LS023  $\varnothing$ 2mm

TB-073 3x67.5mm



### 35 左后支撑脚的安裝2 Left rear supporting leg installation 2

先将卡簧卡住定位轴一头，待整体支撑臂安装无误后，再来卡另一头卡簧。

First the reed stuck in the positioning shaft head, until the overall support arm installation is correct, and then card the other end of the reed.

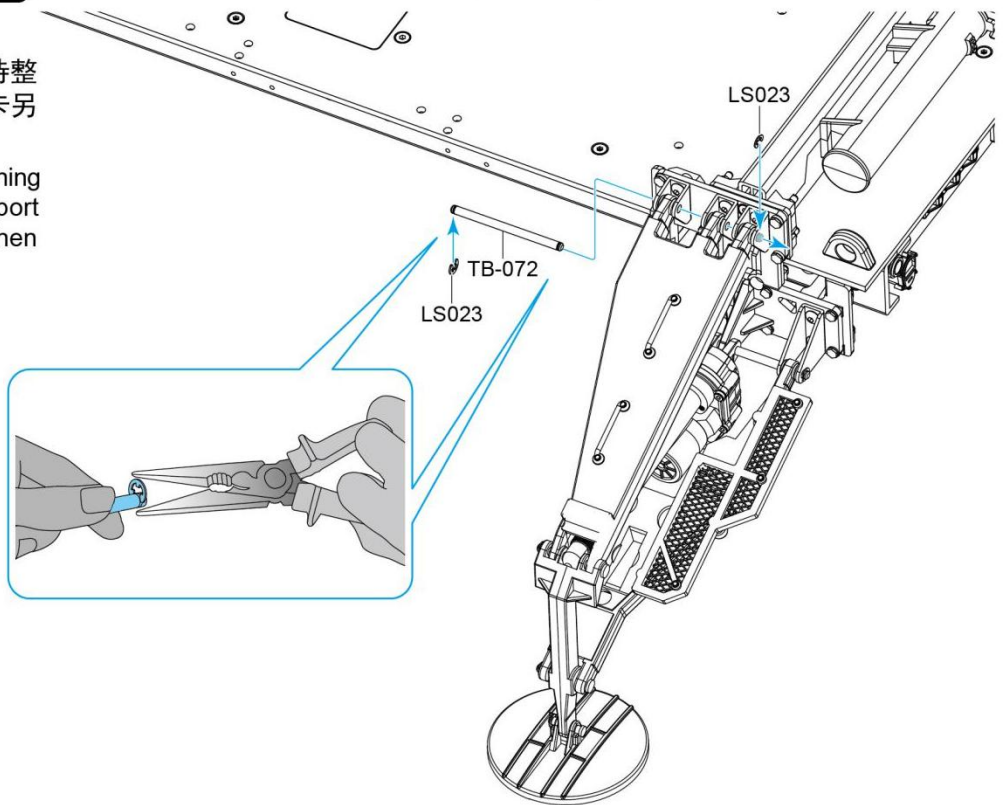

LS023  $\varnothing$ 2mm ..... 2

TB-072 3x45.5mm ..... 1

LSKB-05 KB  $\varnothing$ 2x5MM ..... 6

### 36

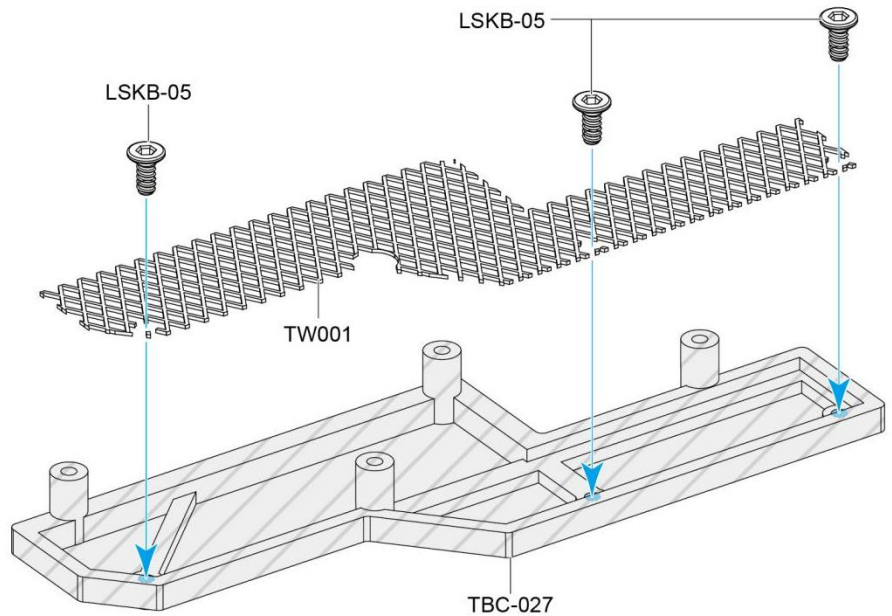

此配件出厂时已组装完成，组装图只是提供组装过程，可用于维护配件。

This accessory was assembled at the factory, and the assembly diagram simply provides the assembly process, can be used to maintain accessories.

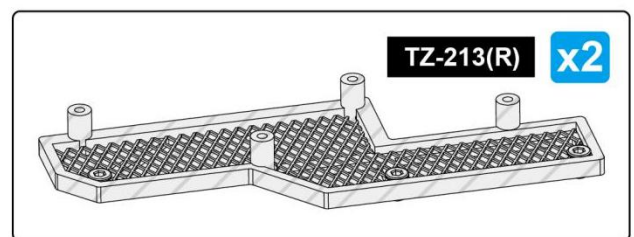

P544 KB Ø2x6MM 8

37

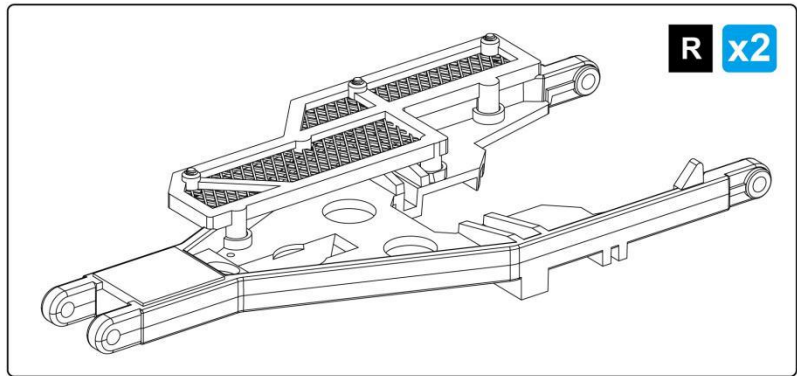
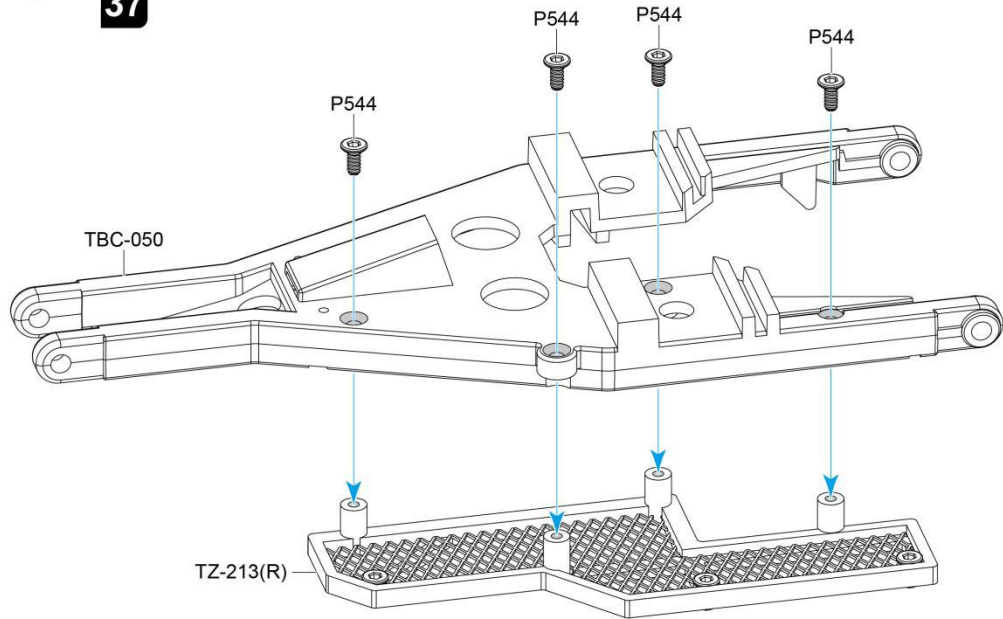

38

LS020 M2 8

TB-8057 M2 8

TB-068 M2 4



此配件出厂时已组装完成，组装图只是提供组装过程，可用于维护配件。  
This accessory was assembled at the factory, and the assembly diagram simply provides the assembly process, can be used to maintain accessories.

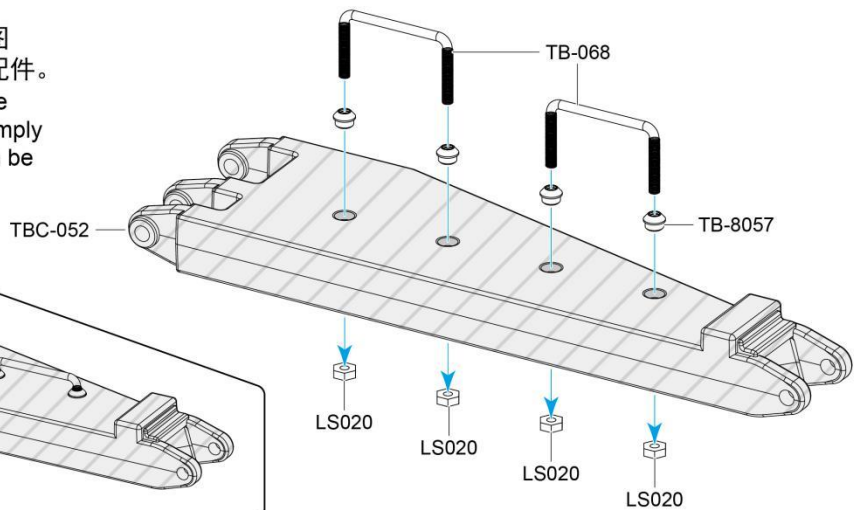
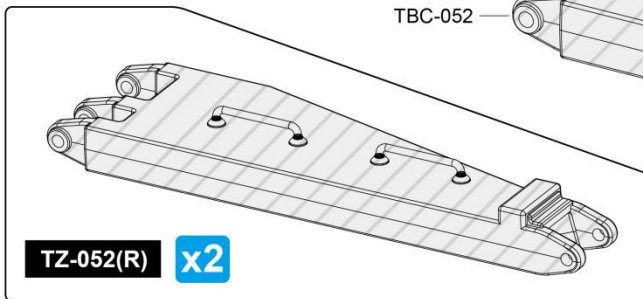

39

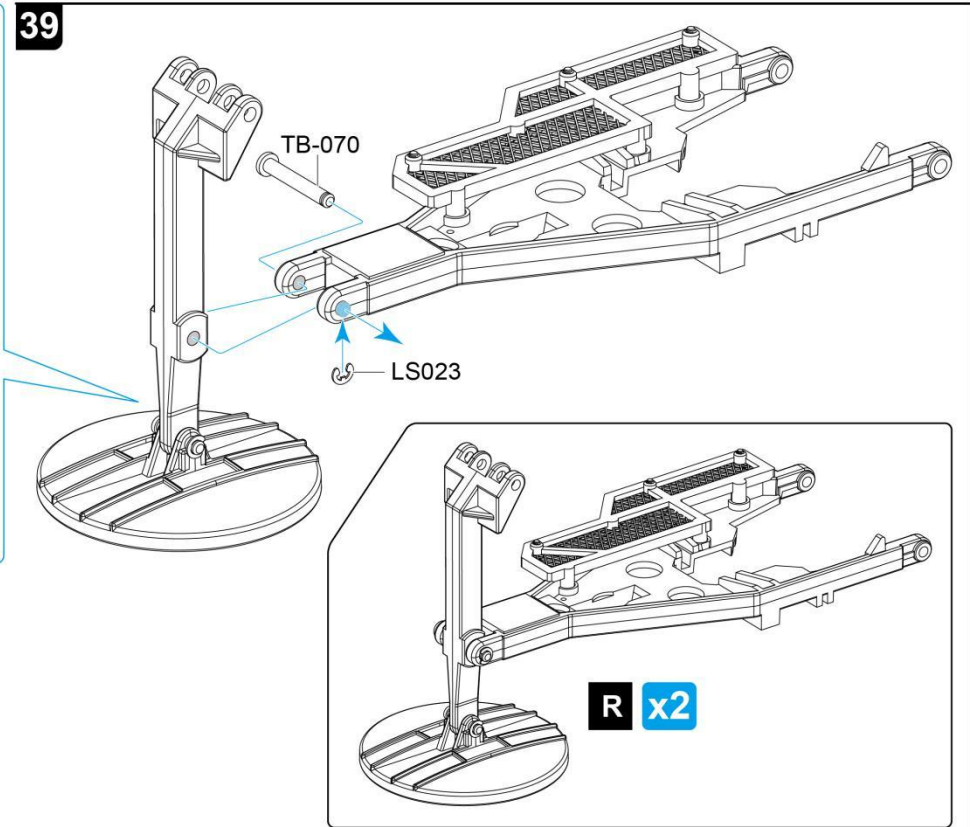
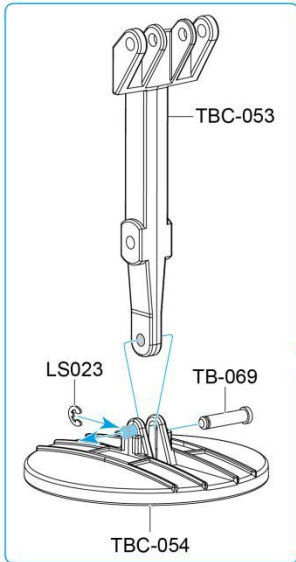

-----4  
 LS023 Ø2mm

-----2  
 TB-069 Ø3x14mm

-----2  
 TB-070 Ø3x22mm

40

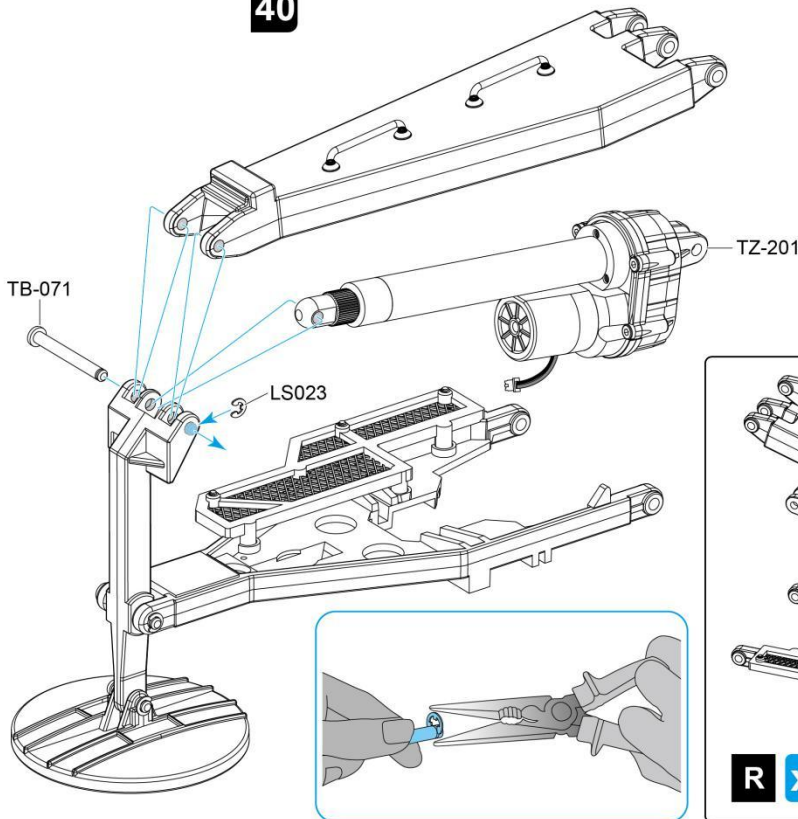



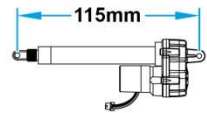

-----2  
 LS023 Ø2mm

-----2  
 TB-071 Ø3x28mm

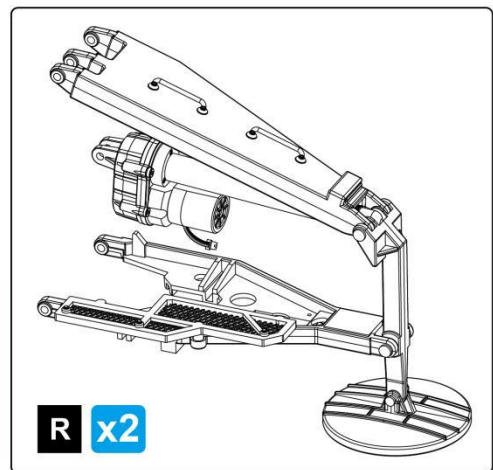

TZ-201 Ø115mm -----2



-  ..... 4  
LS023 Ø2mm
-  ..... 1  
TB-072 Ø3x45.5mm
-  ..... 1  
TB-073 Ø3x67.5mm

### 41 右前支撑脚的安装 Right front supporting leg installation

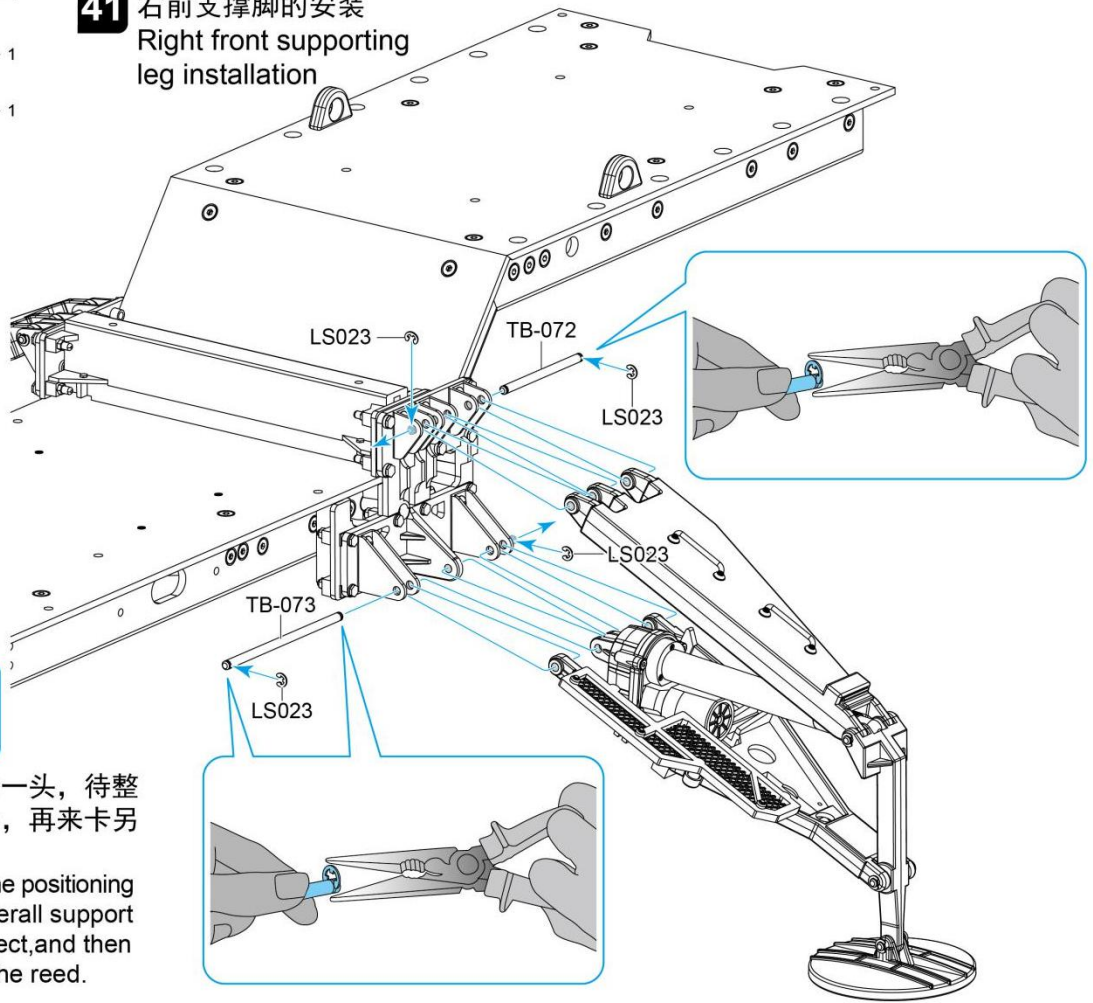

 **注意**  
Caution



先将卡簧卡住定位轴一头，待整体支撑臂安装无误后，再来卡另一头卡簧。  
First the reed stuck in the positioning shaft head, until the overall support arm installation is correct, and then card the other end of the reed.

 **注意**  
Caution

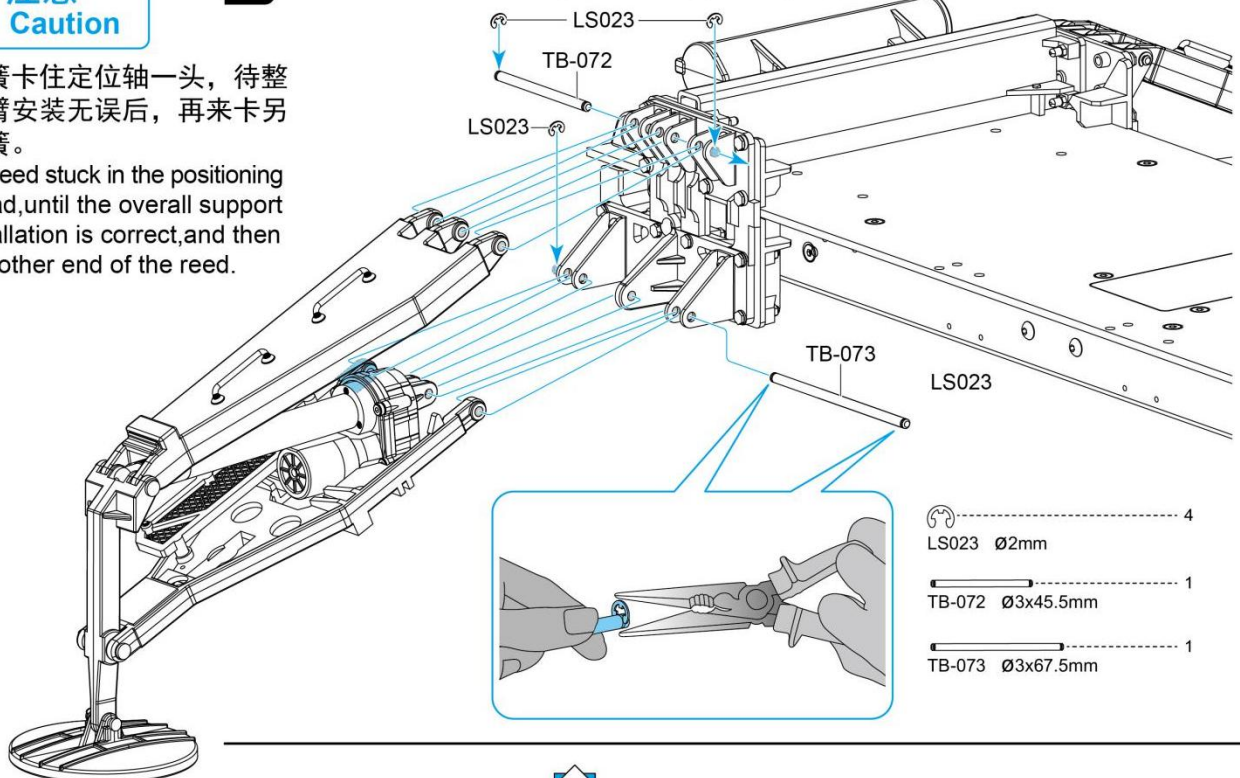
### 42 右后支撑脚的安装 Right rear supporting leg installation



先将卡簧卡住定位轴一头，待整体支撑臂安装无误后，再来卡另一头卡簧。  
First the reed stuck in the positioning shaft head, until the overall support arm installation is correct, and then card the other end of the reed.

-  ..... 4  
LS023 Ø2mm
-  ..... 1  
TB-072 Ø3x45.5mm
-  ..... 1  
TB-073 Ø3x67.5mm

W05009 HM Ø2x6MM 3

P001 KM Ø3x8MM 6

43

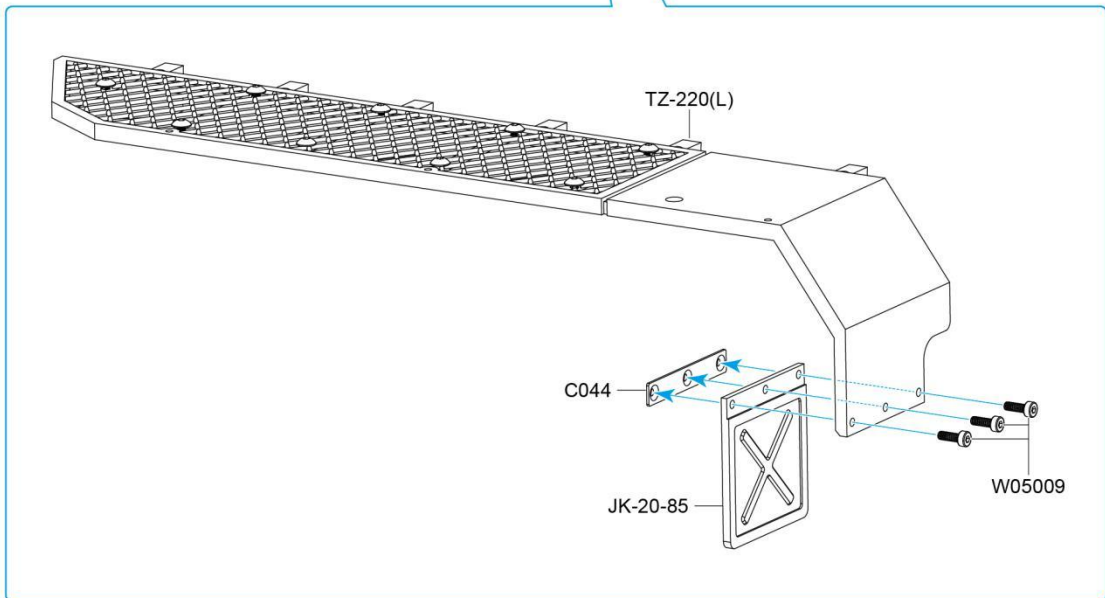
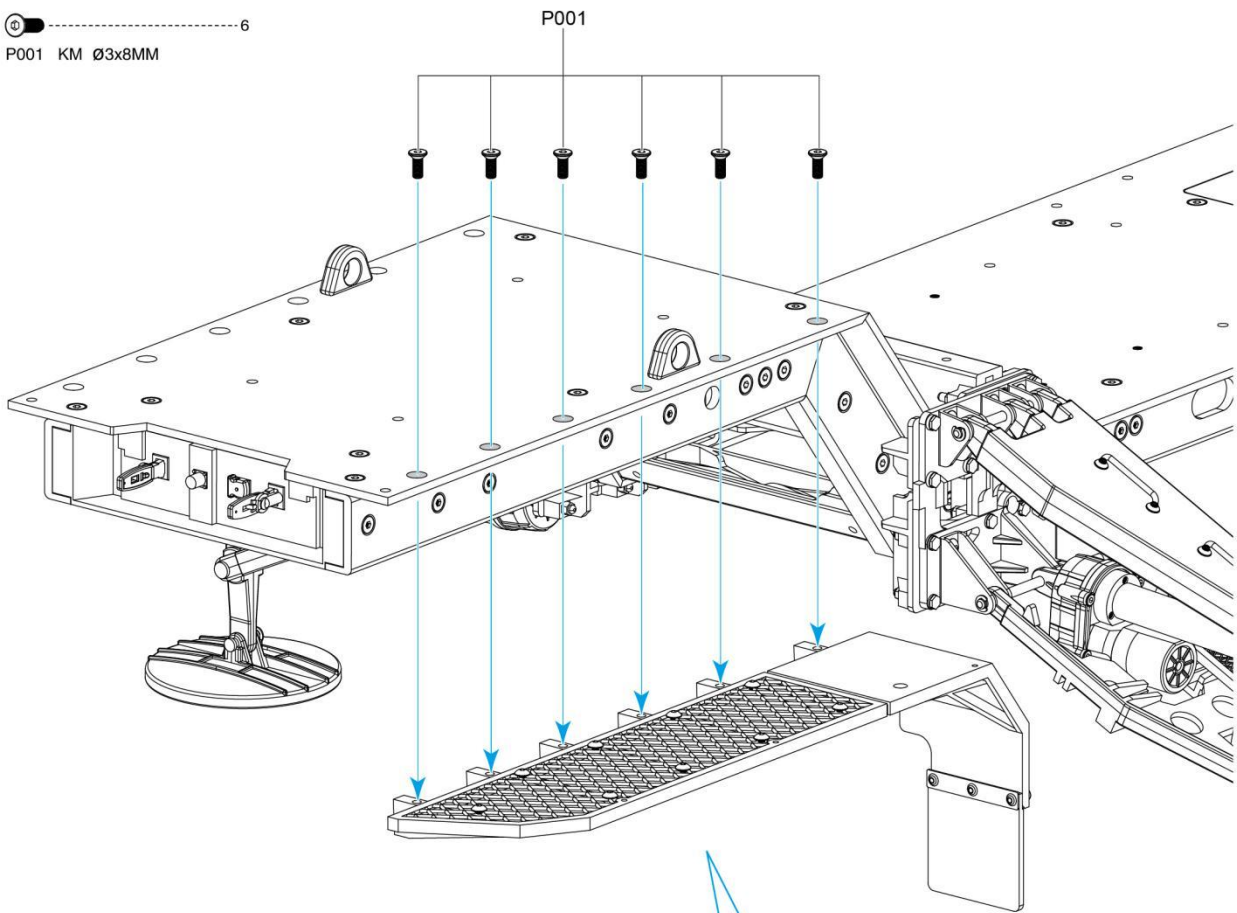

③ ..... 3  
W05009 HM Ø2x6MM

④ ..... 6  
P001 KM Ø3x8MM

**44**

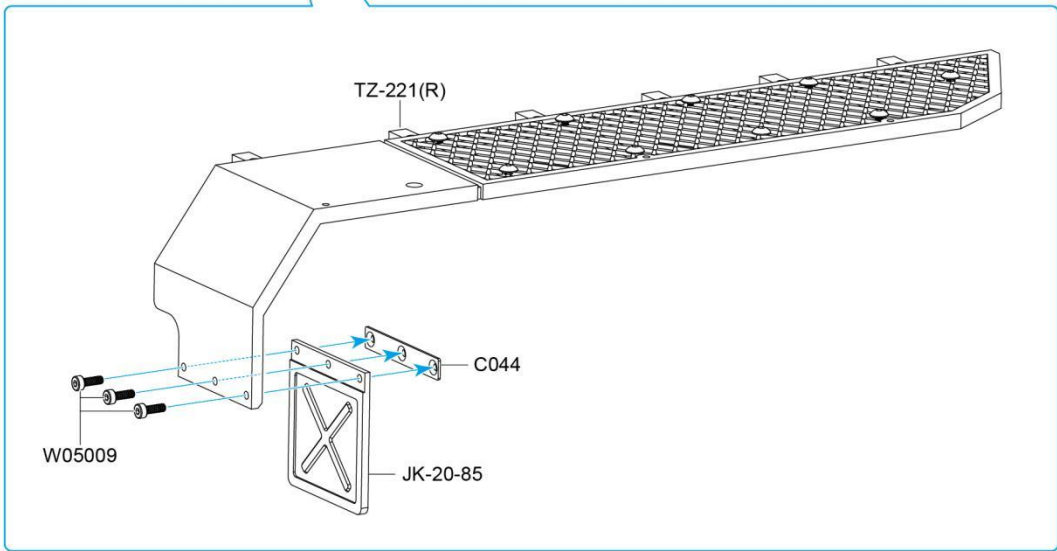
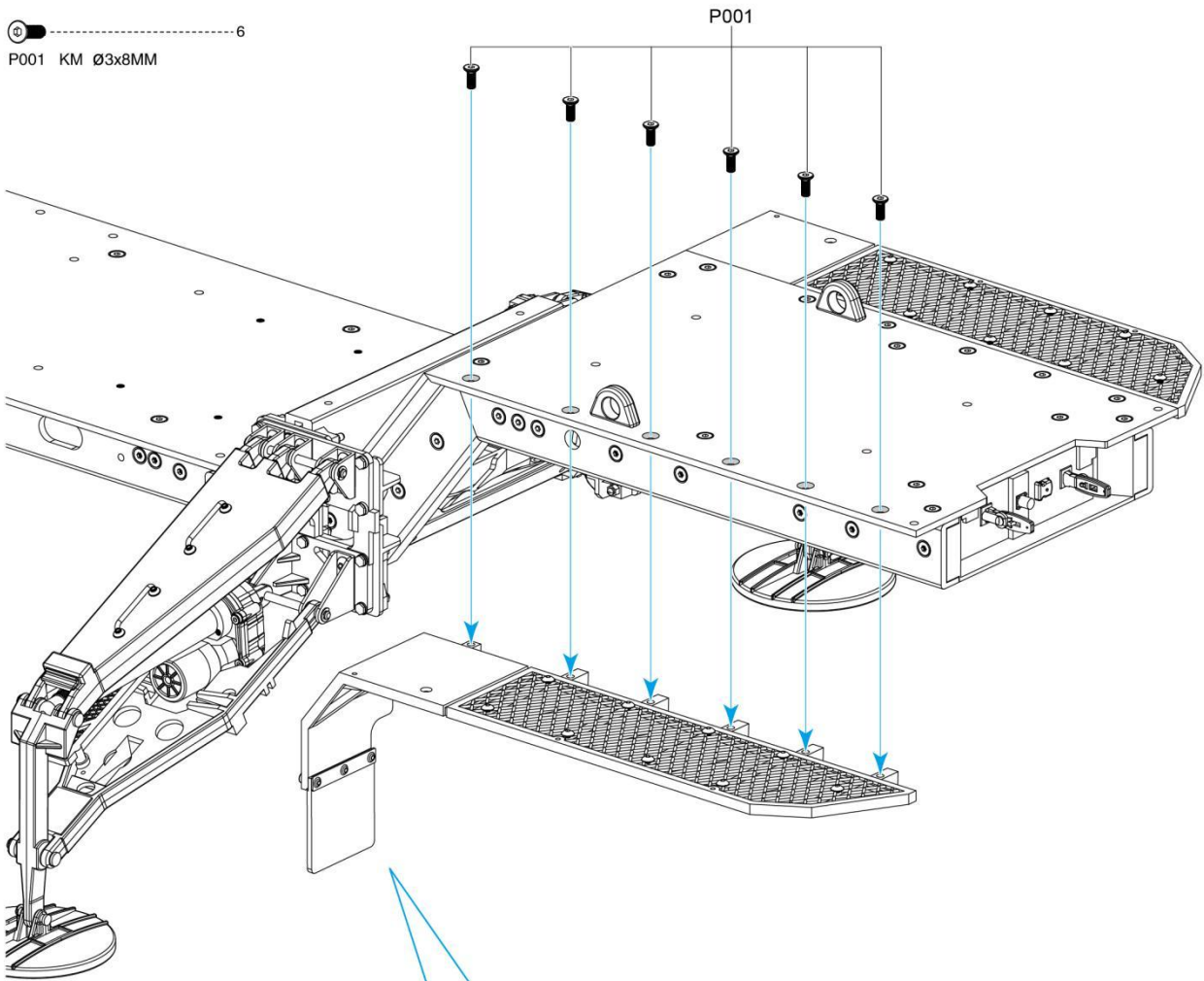



LS001 TM Ø3x6MM 4

45

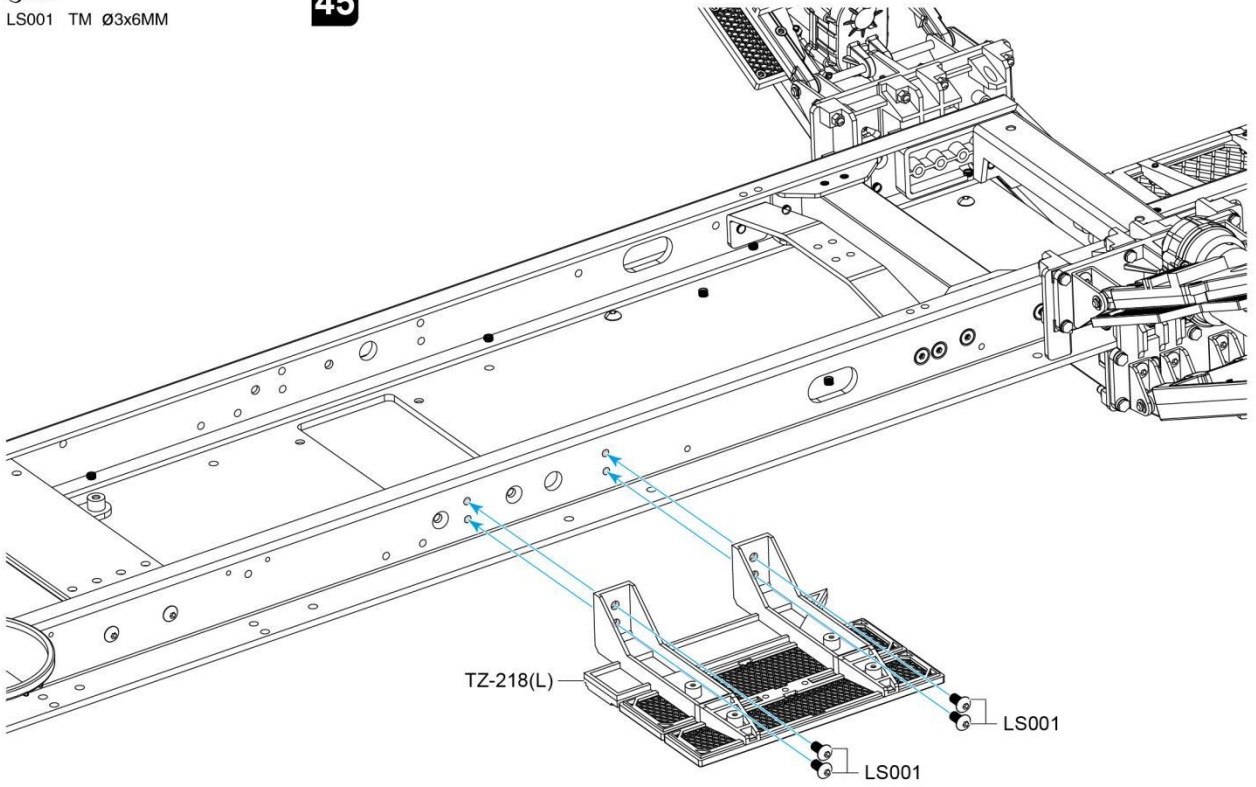

LS001 TM Ø3x6MM 4

46

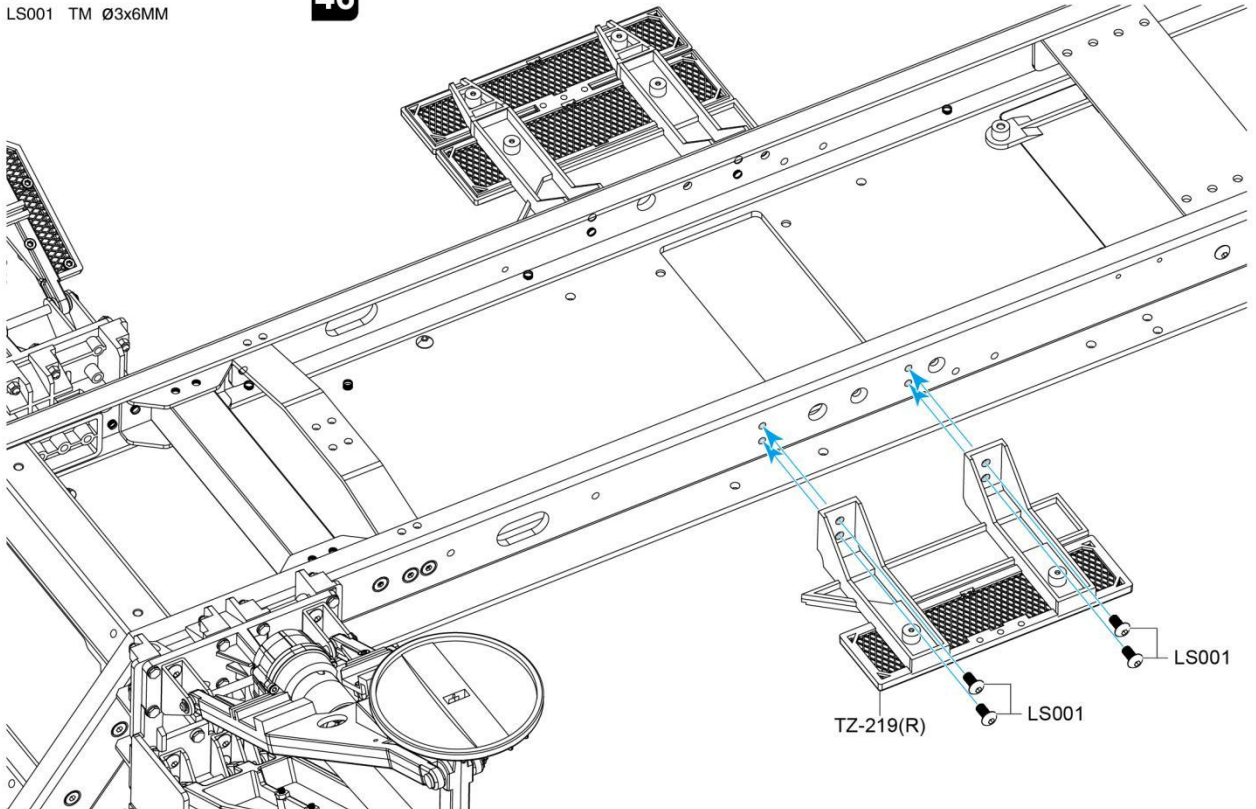

- 4
- P5612 HB Ø2.6x8MM
- 1
- KB143 KB Ø1.4x3MM

**47**

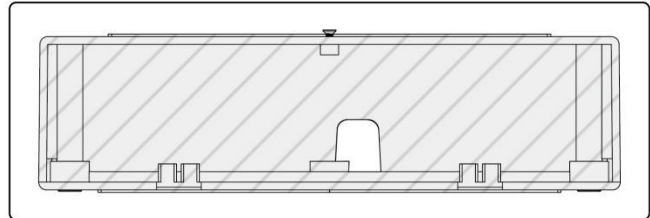
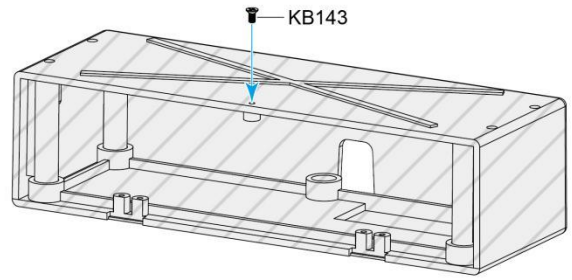
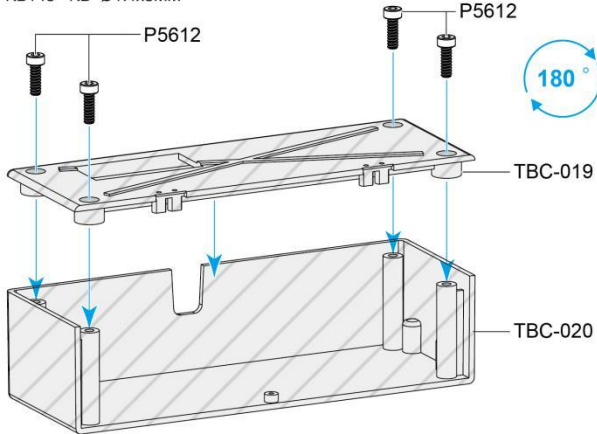

- 5
- KB143 KB Ø1.4x3MM

**48**

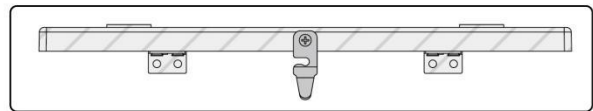
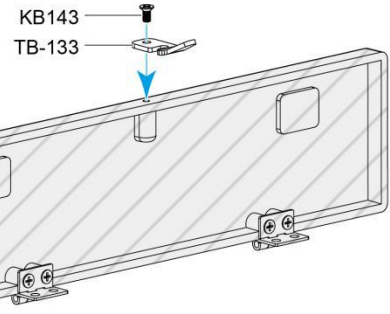
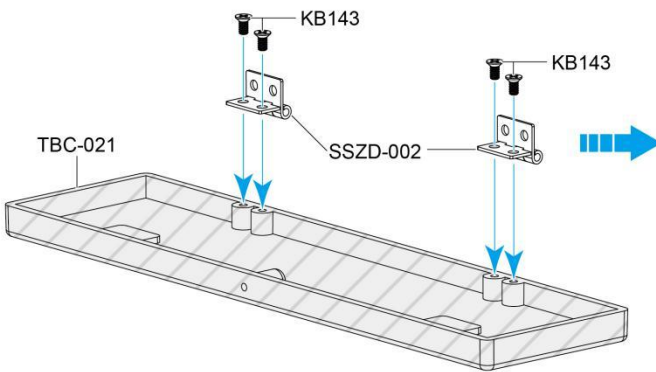

- 4
- KB143 KB Ø1.4x3MM
- 4
- P5612 HB Ø2.6x8MM

**49**

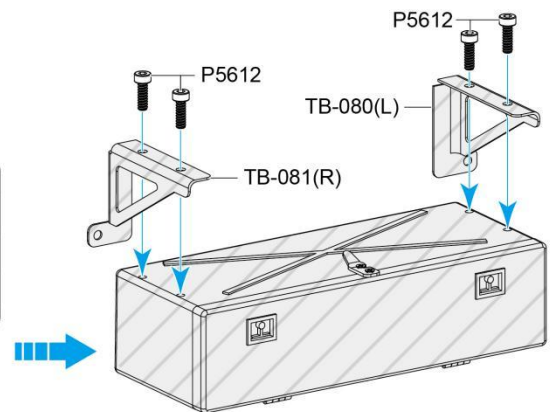
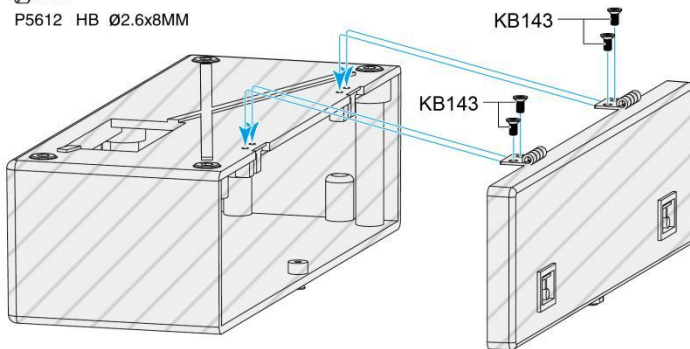

此配件出厂时已组装完成，组装图只是提供组装过程，可用于维护配件。  
This accessory was assembled at the factory, and the assembly diagram simply provides the assembly process, can be used to maintain accessories.



LSZ0701 TM Ø3x5MM

50

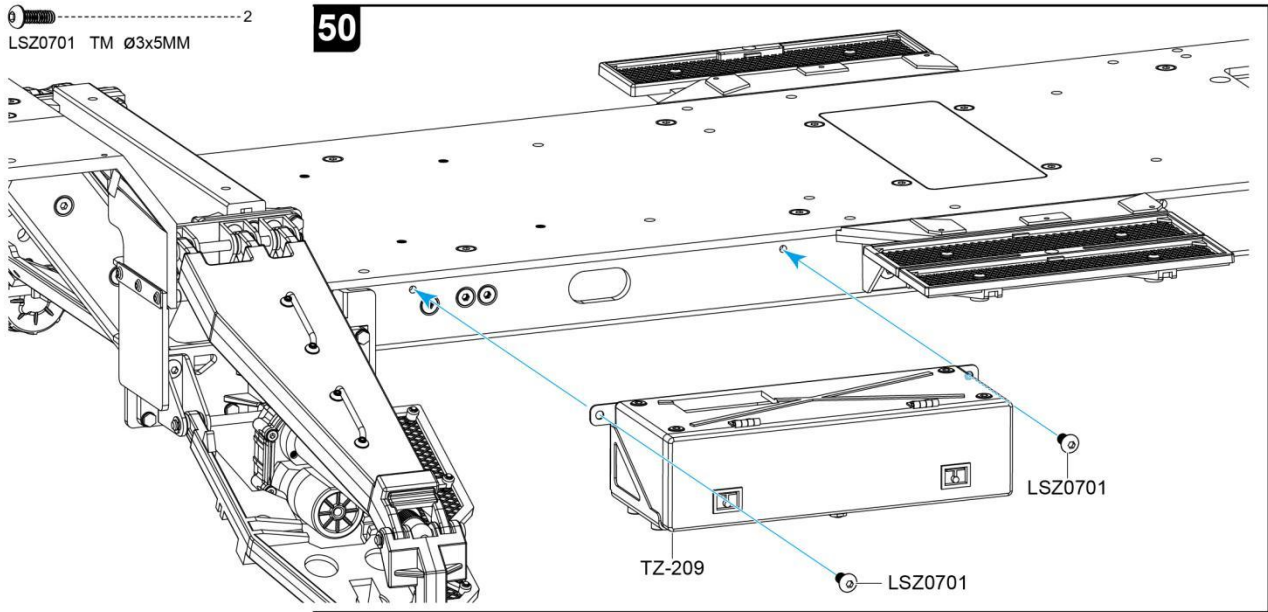

P544 KB Ø2x6MM

TB-098-1

KB143 KB Ø1.4x3MM

51

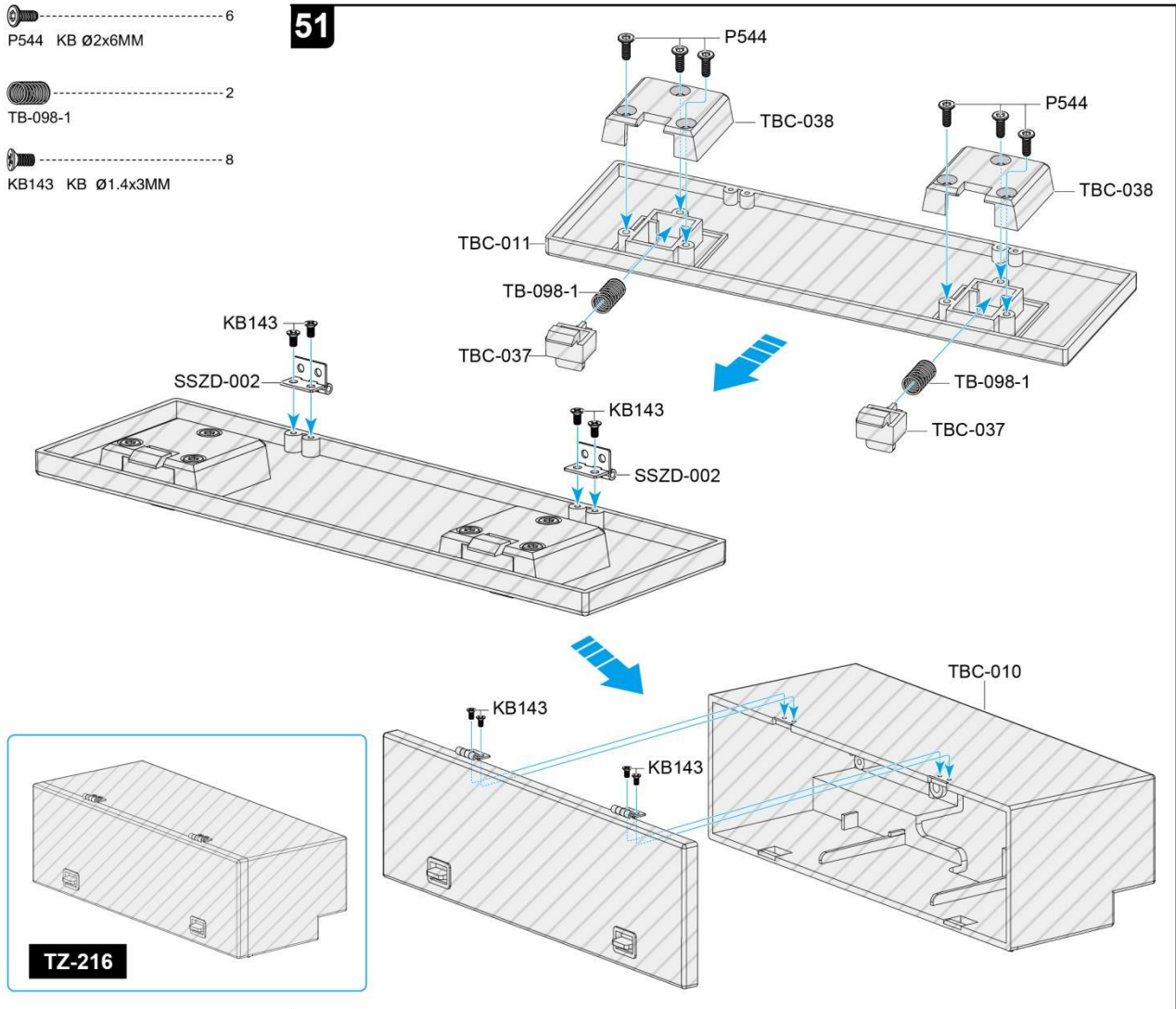



**注意**  
**Caution**

线路连接好后，电线两端贴上标签，以便日后辨识。  
Once the wires are connected, label both ends of the wire for later identification.

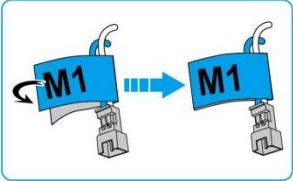

- LS078 TM  $\varnothing 3 \times 8 \text{mm}$  ..... 2
- DX07 M1(43cm) ..... 1
- DX06 M2(26cm) ..... 1
- DX09 M5(77cm) ..... 1
- DX08 M6(71cm) ..... 1
- XC-106 (30cm) ..... 1

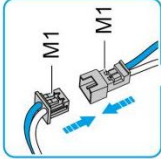

T插头电源线，  
连接电池。  
T plug the male  
power cable  
connect battery

52

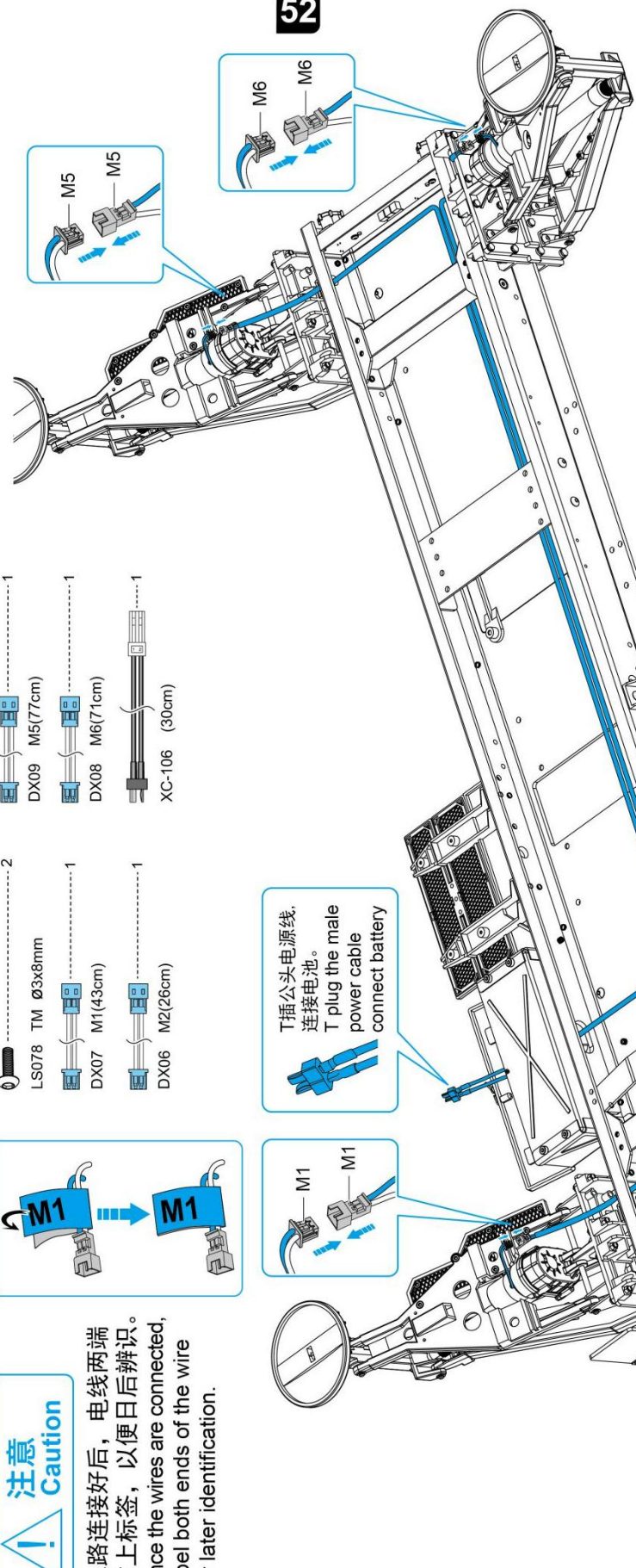

JST插头连接小稳压电源插头(预留线仅用于小  
遥控器操控时连接)  
The JST plug is connected to a small regulated  
power plug (the reserved wire is only used for  
connections when the small transmitter is  
operating.)

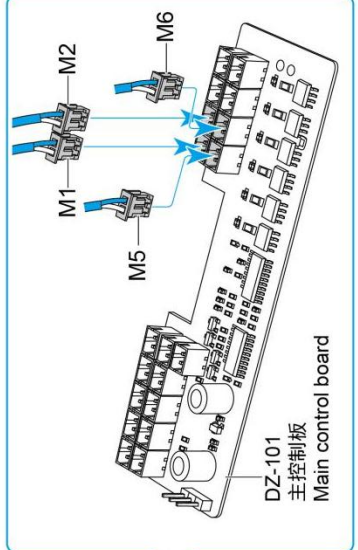

DZ-101  
主控制板  
Main control board

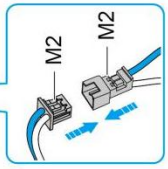

④ ..... 4  
LSTB38 TB Ø3x8MM

**53**

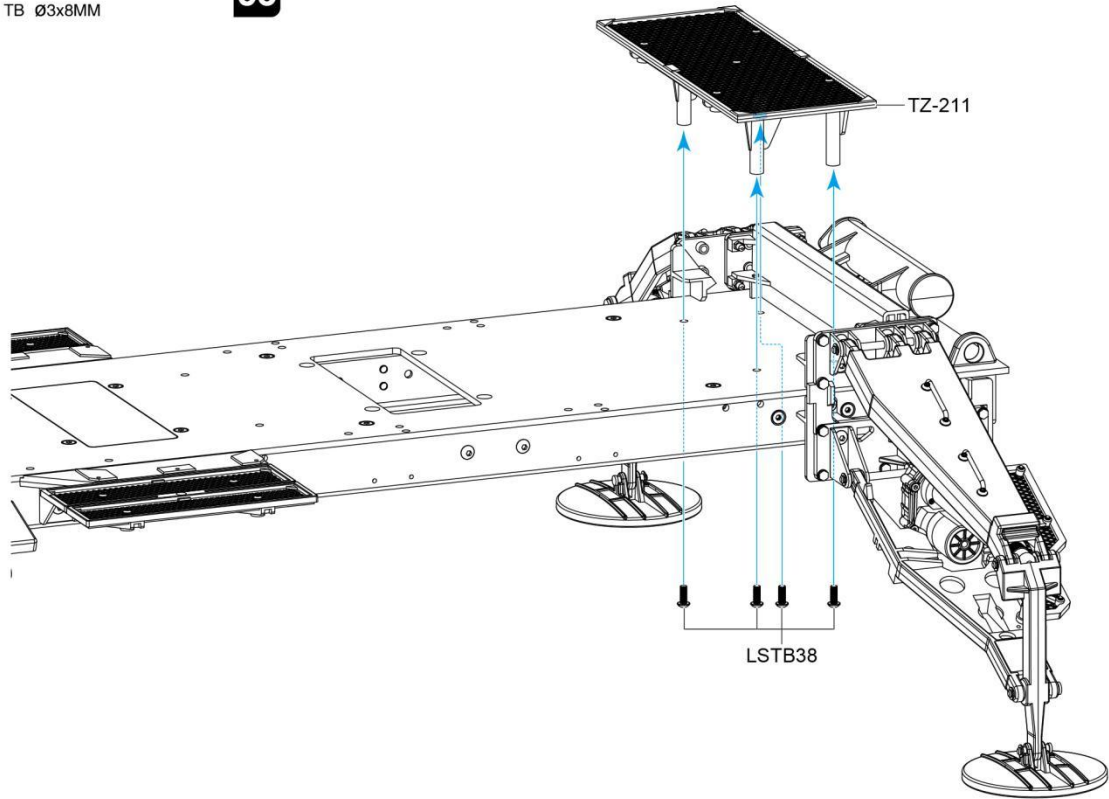

⑤ ..... 5  
LSTB-26 TB Ø2x6MM

② ..... 2  
LS089 KM Ø3x14MM

**54**

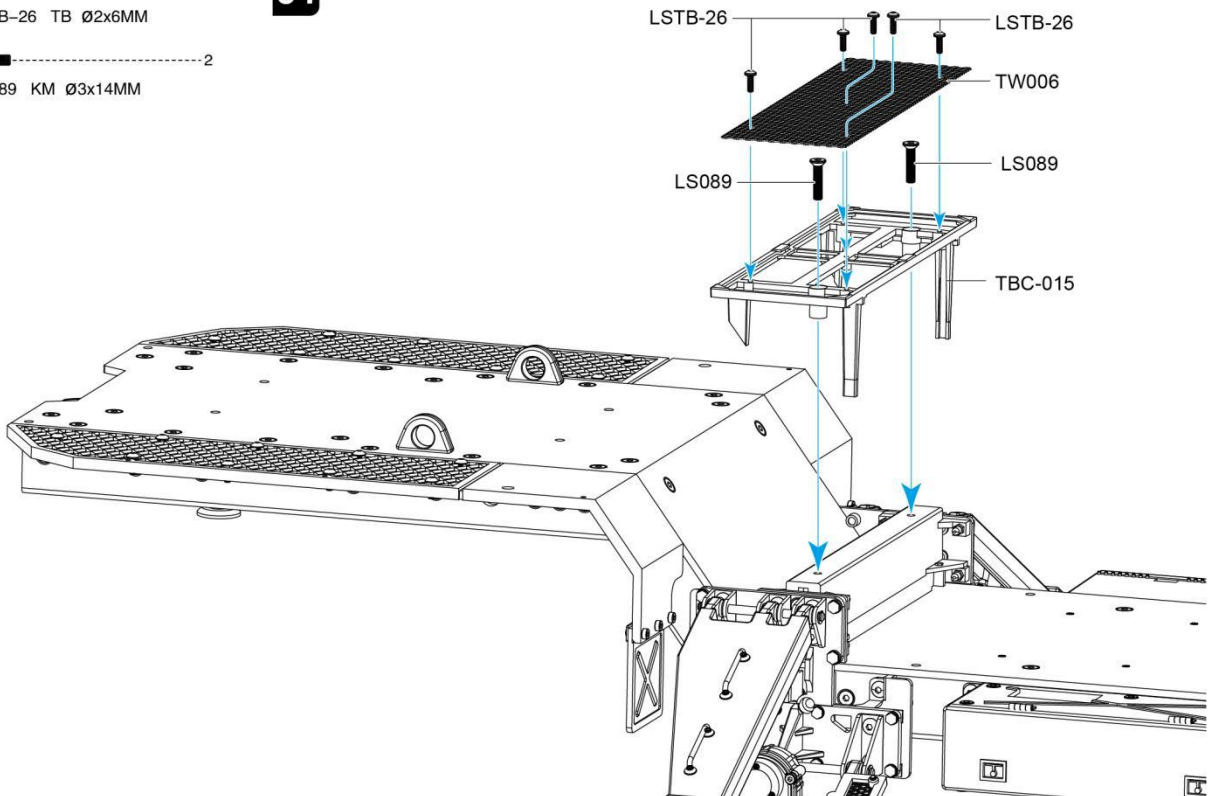

LSKB-212 KB Ø2X12MM 32

55

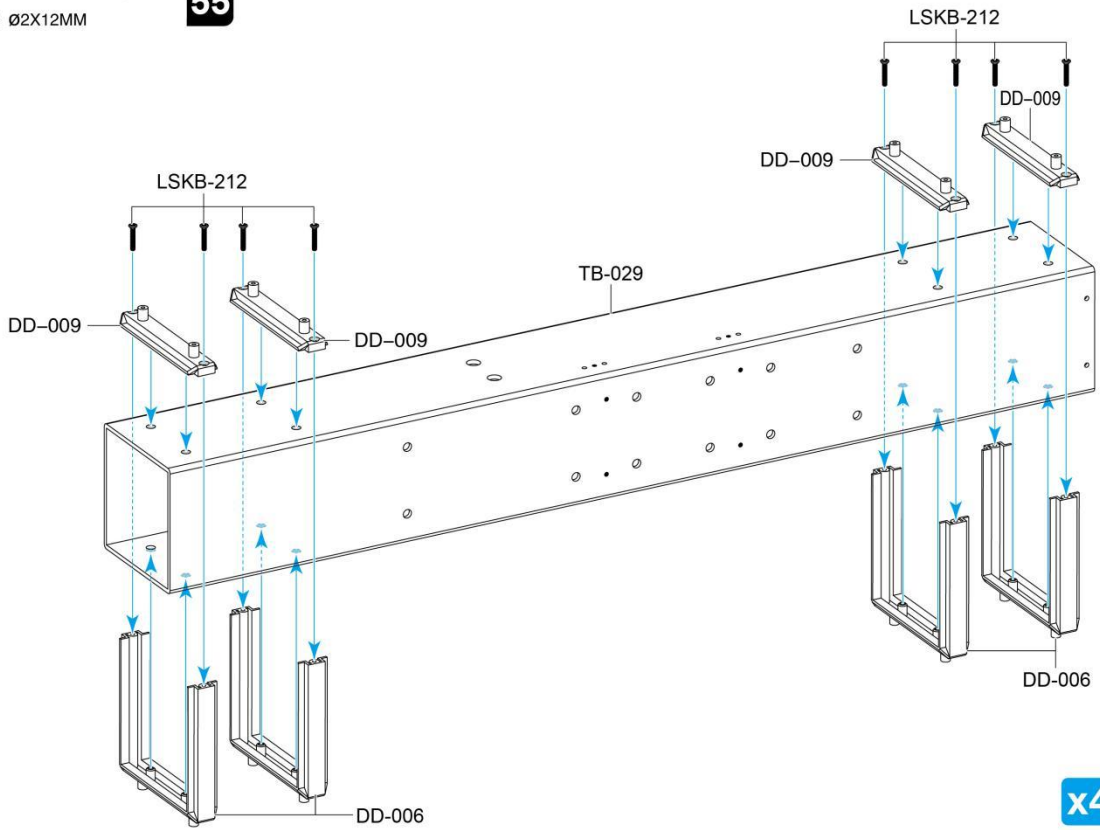

LSKB-212 KB Ø2X12MM 16

56

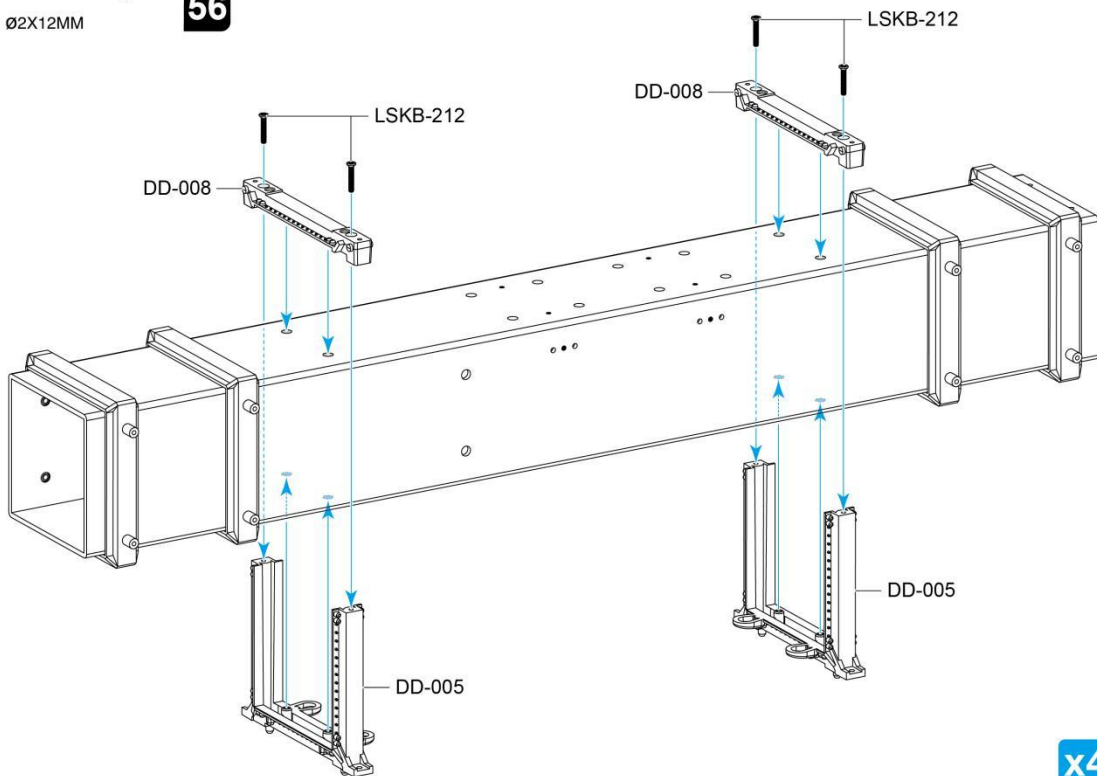

LSKB-212 KB Ø2X12MM 8

57

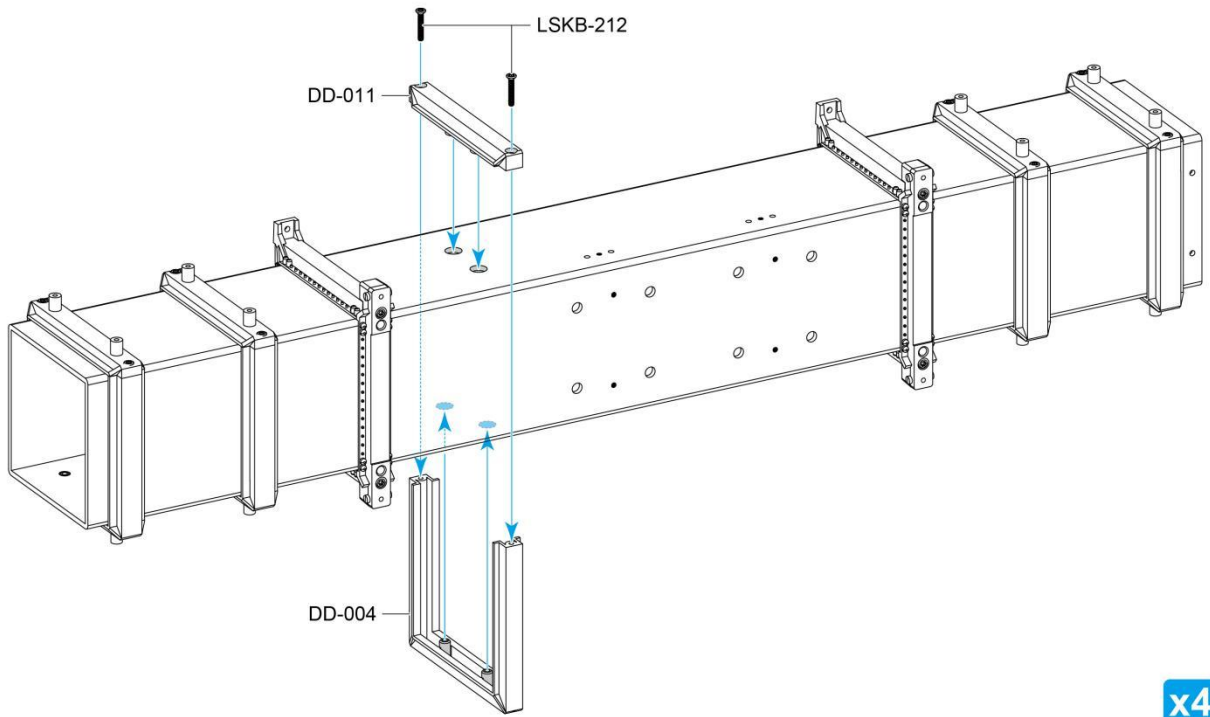

x4

LSKB-212 KB Ø2X12MM 32

58

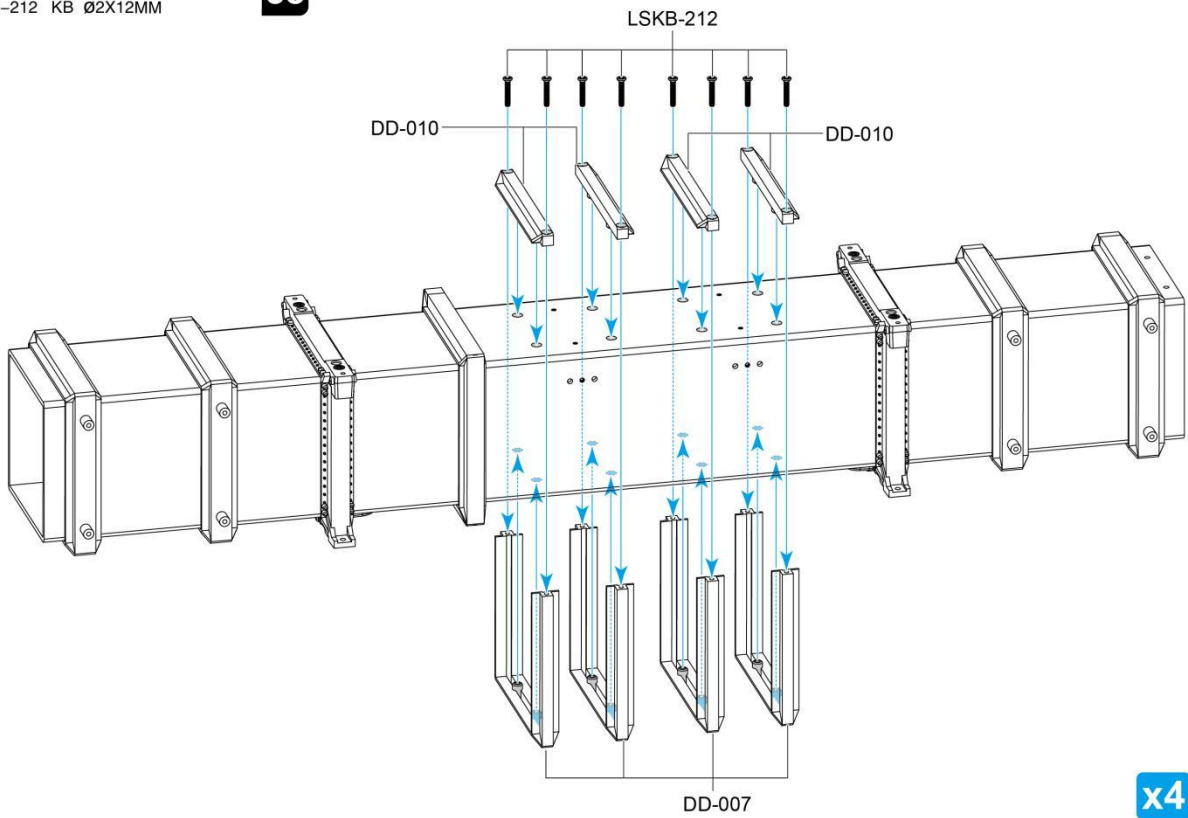

x4

16  
LS776 KM Ø2X8MM

59

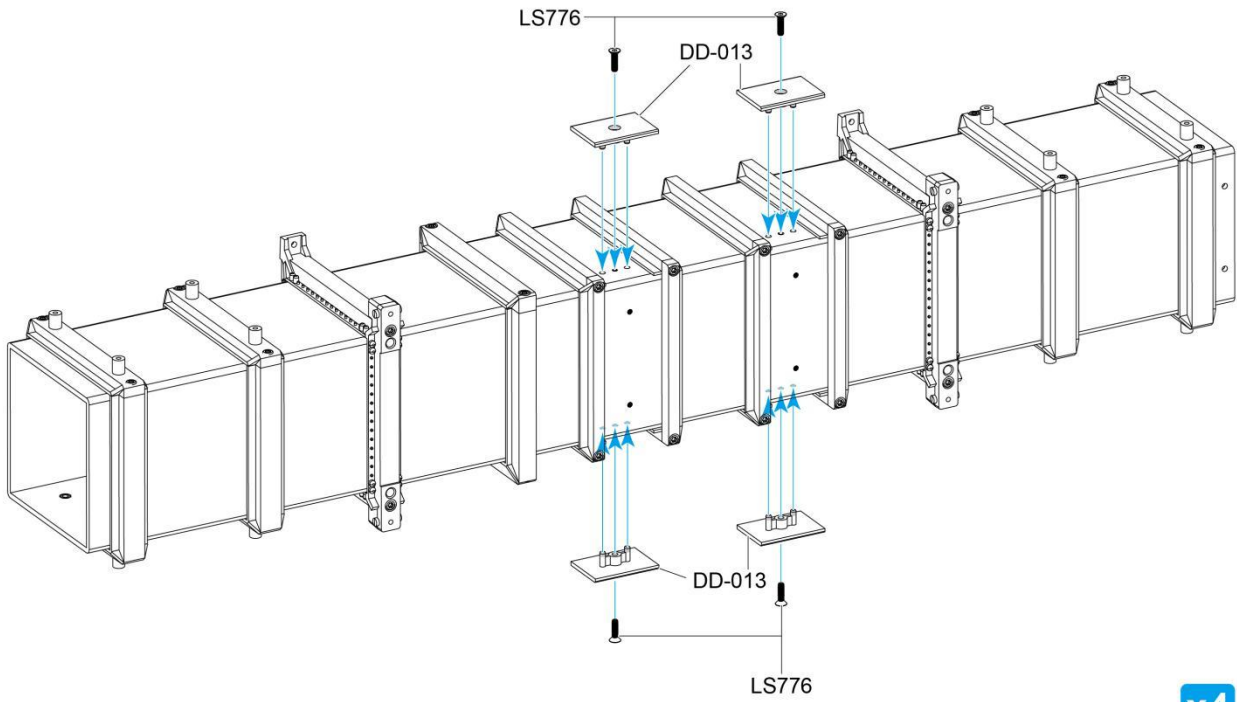

16  
LSKM-210 KM Ø2X10MM

60

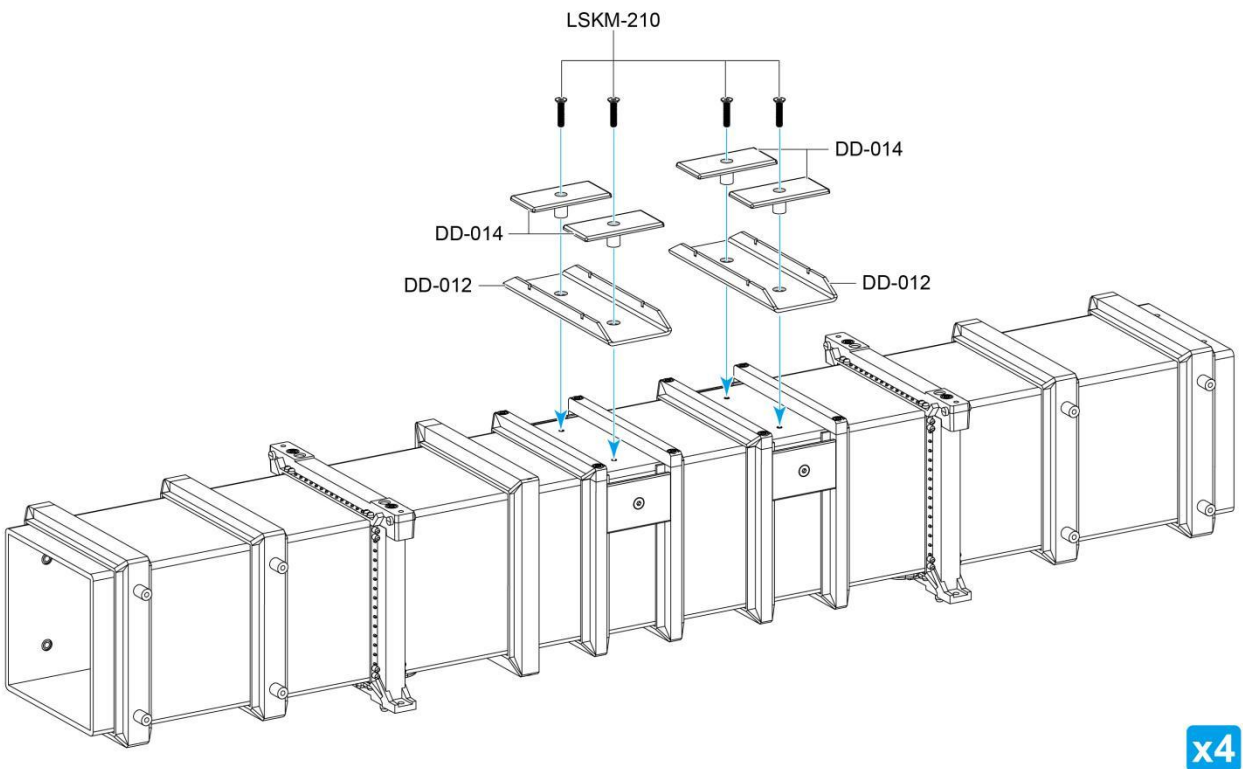



-  ..... 16  
W05009 HM Ø2x6MM
-  ..... 8  
LSTB-36 TB Ø3x6MM

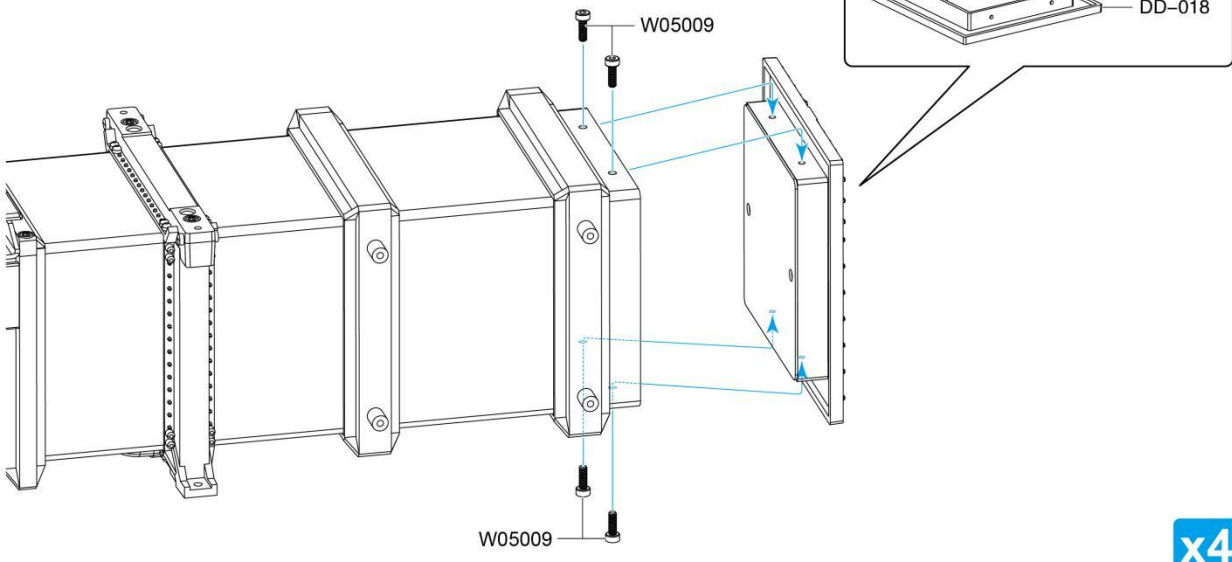

**61**

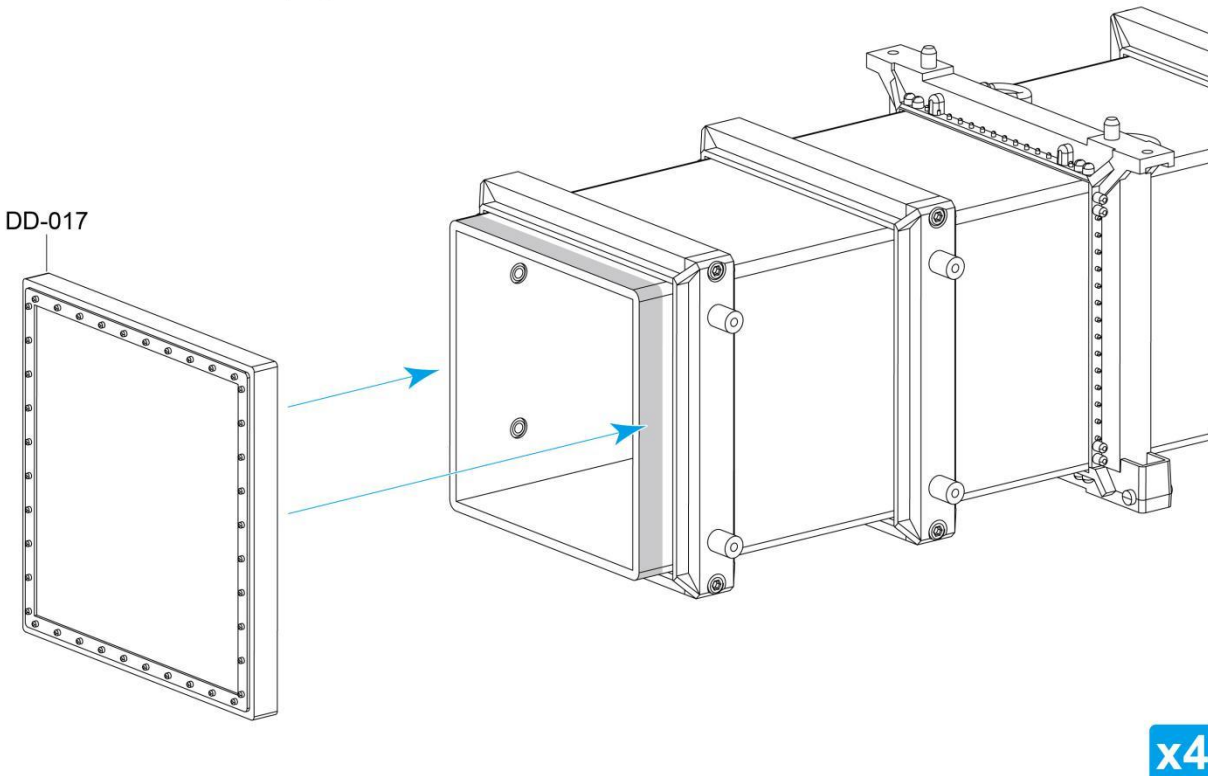

**62**



x2

-  LS020 M2 ..... 8
-  W05011 HM Ø2x10MM ..... 8

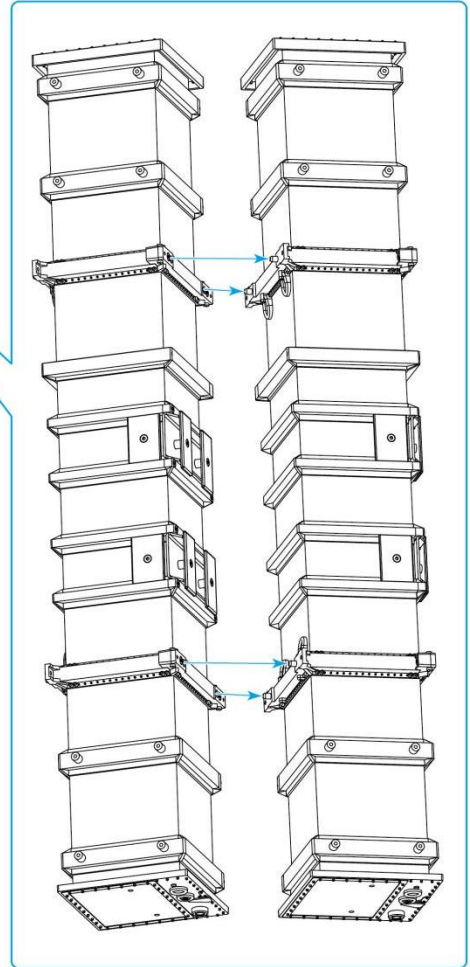
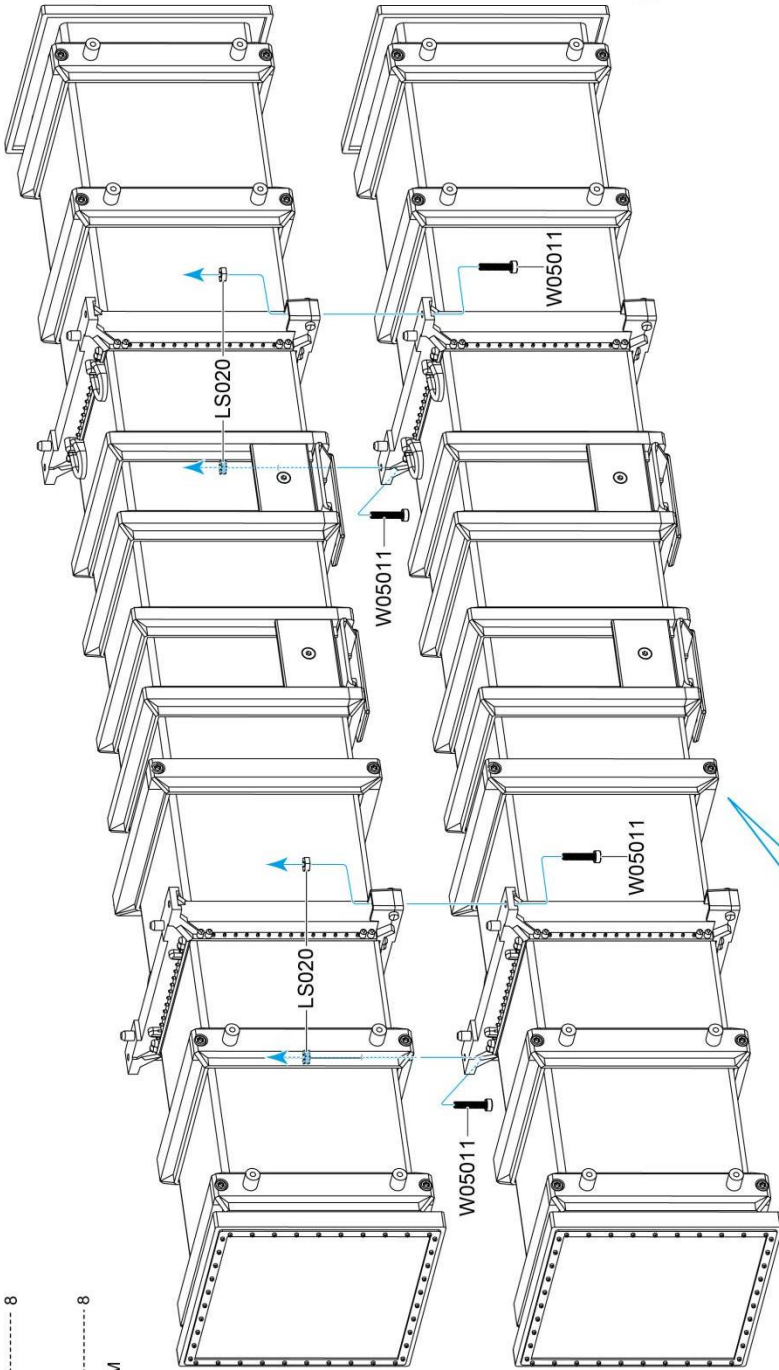

**注意**  
Caution



4块底盖的装配方向要一致。  
The four bottom covers should be assembled in the same direction.

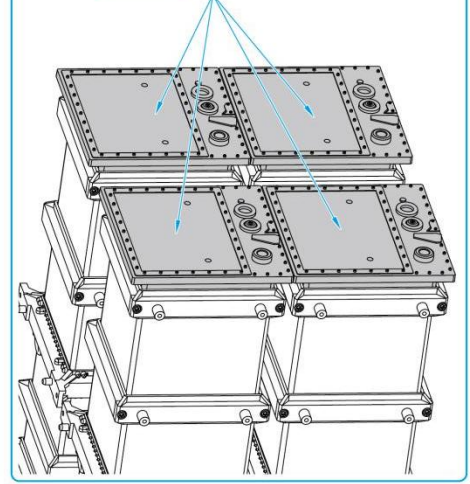

LSKB-210 KB Ø2X10MM

LSKB-210

DD-015

DD-016

LSKB-210

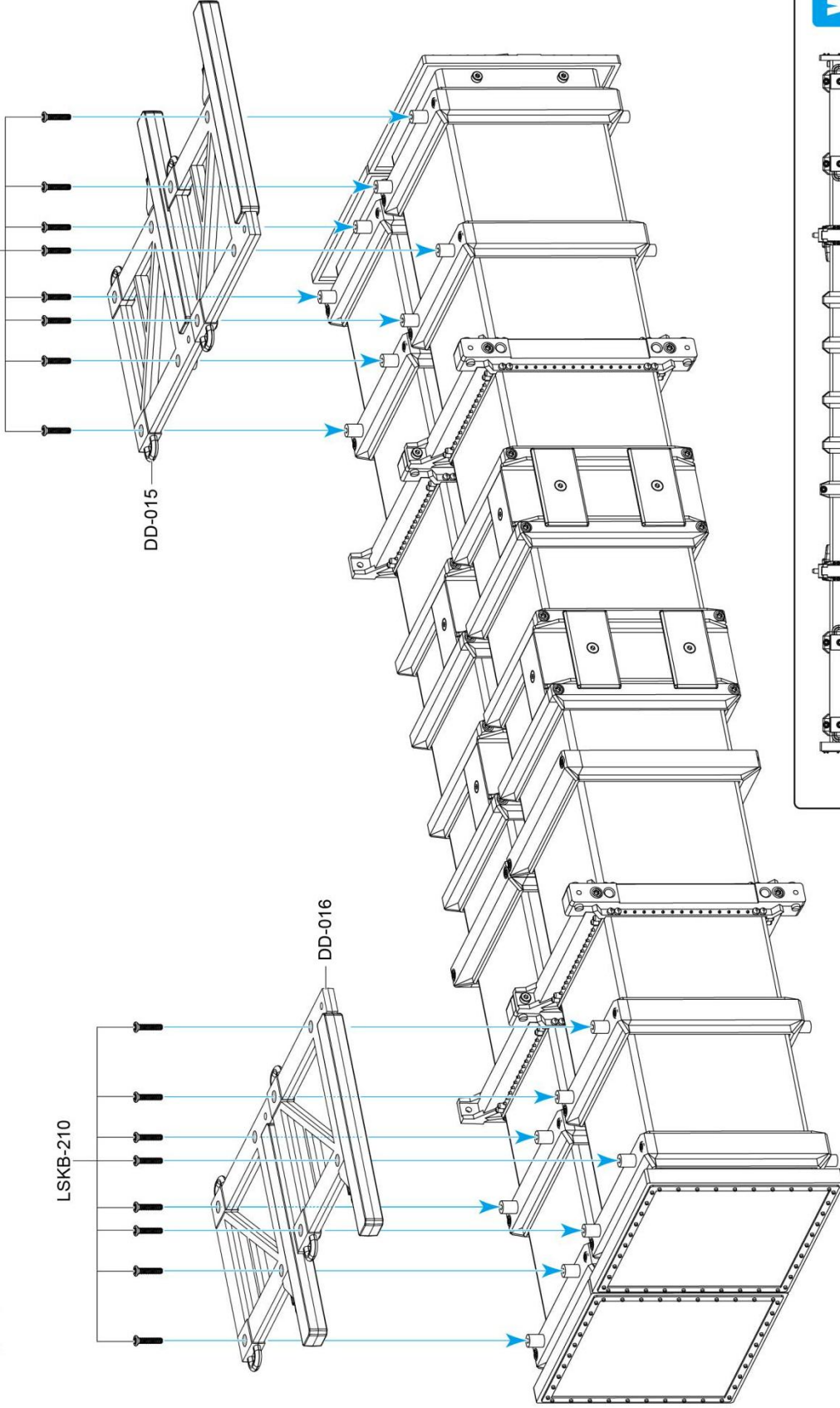

x2

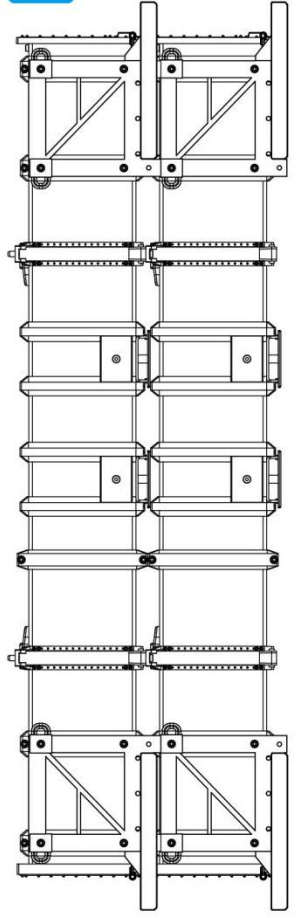

LSKB-210

LSKB-210 KB Ø2X10MM



DD-016

LSKB-210

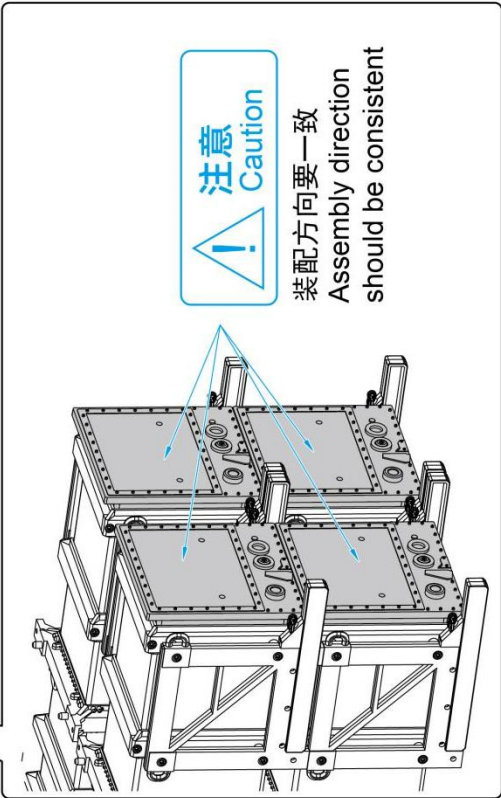
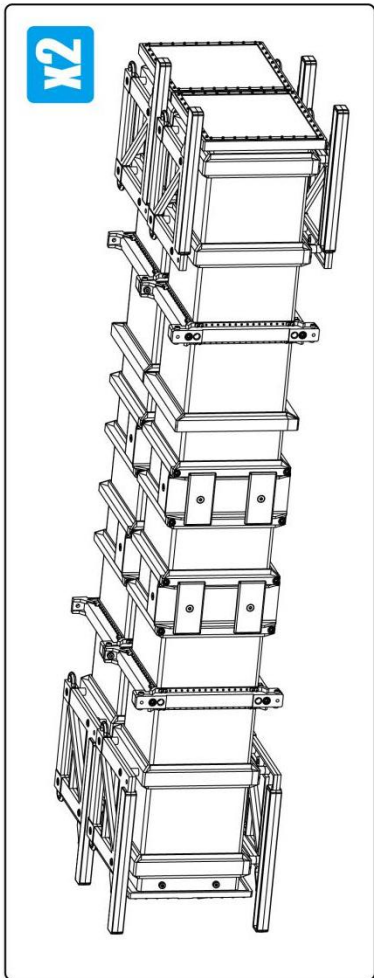
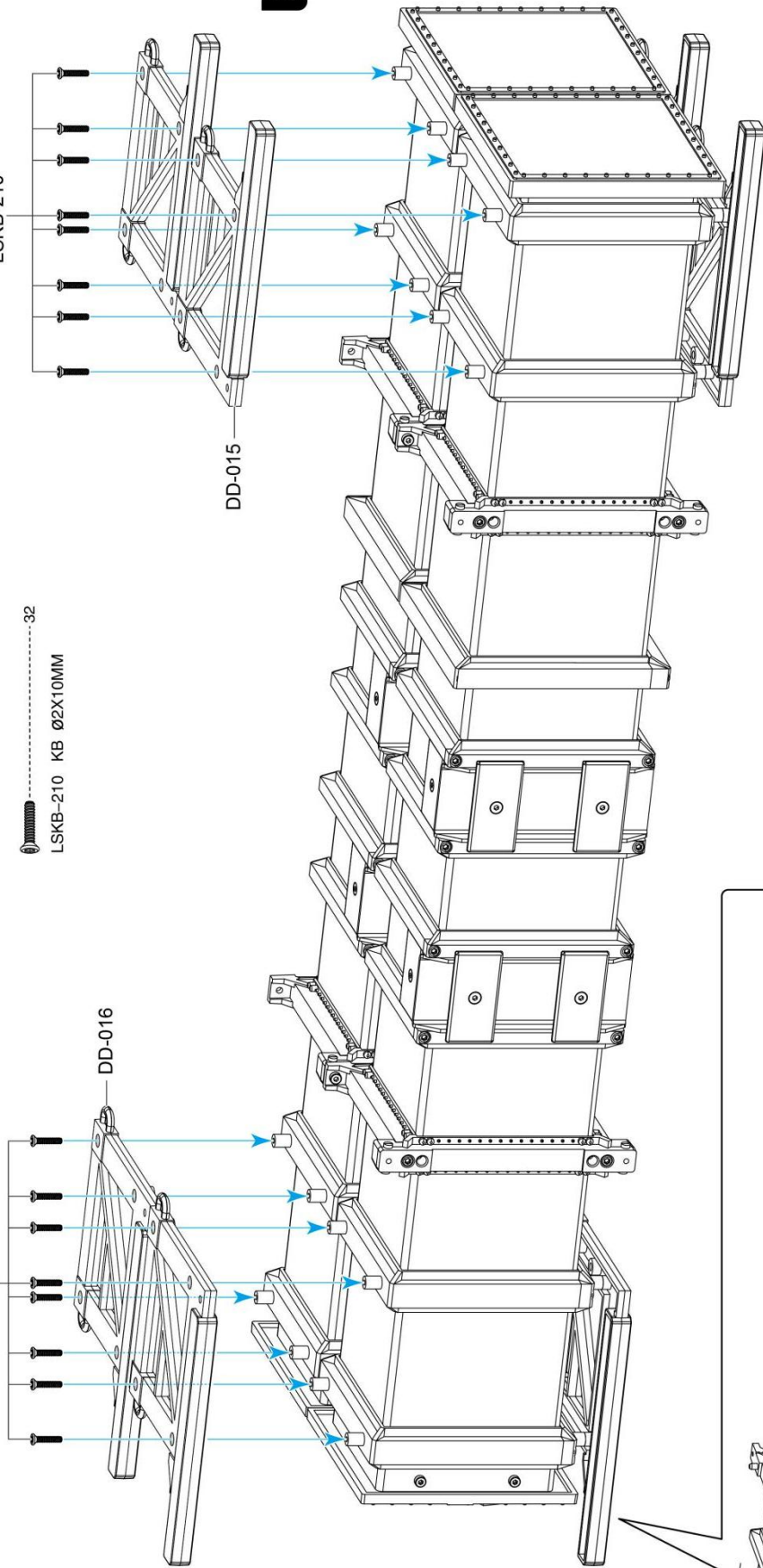

注意  
Caution

装配方向要一致  
Assembly direction  
should be consistent

66

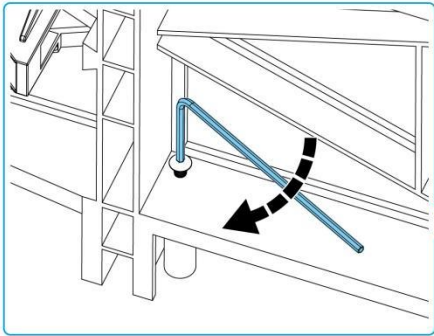

 **注意**  
**Caution**

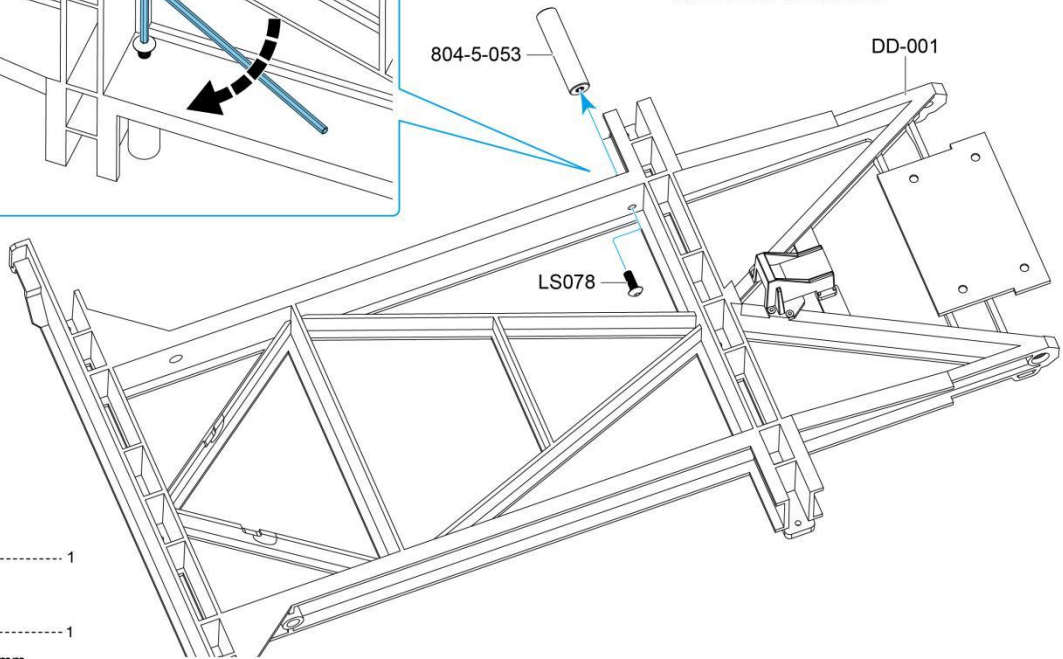

使用内六角扳手，顺时针方向拧紧螺丝。  
Using an inner hexagon wrench, tighten the screws clockwise.

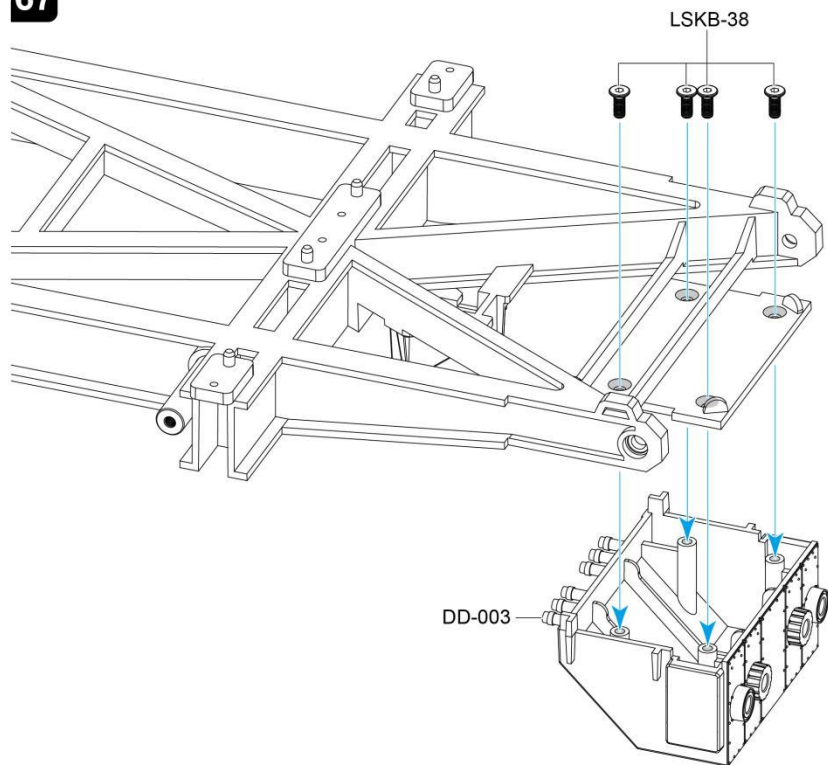

-  ..... 1  
LS078 TM Ø3x8mm
-  ..... 1  
804-5-053 Ø8X34.5mm
-  ..... 4  
LSKB-38 KB Ø3x8MM

67



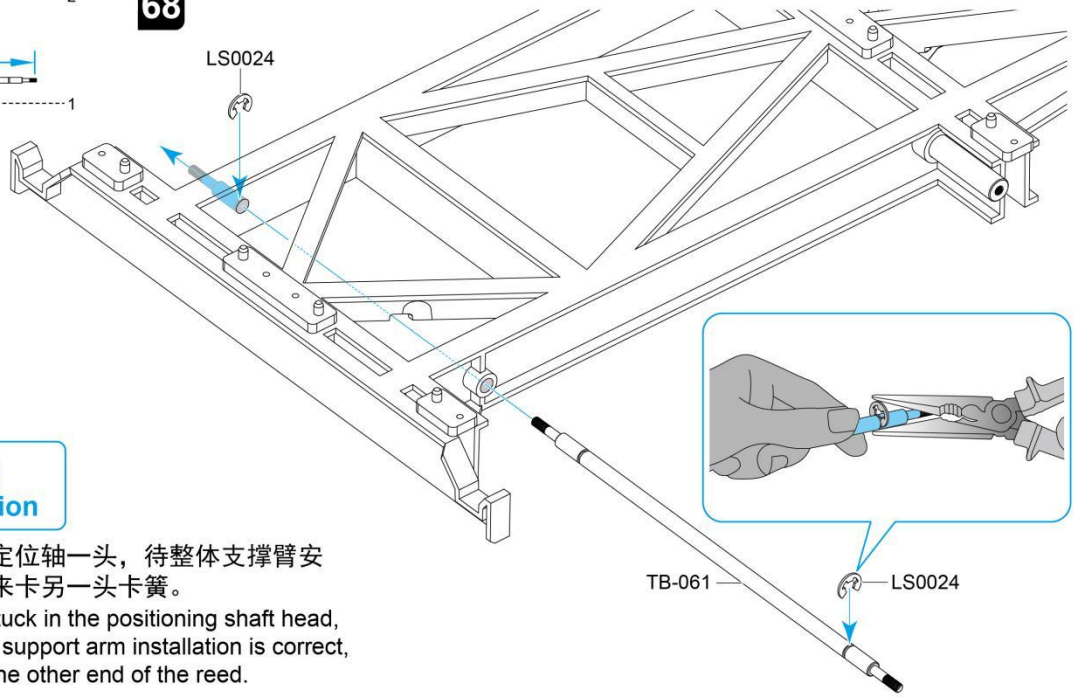

-  ..... 2  
LS024  $\varnothing$ 4mm
-  175mm
- TB-061  $\varnothing$ 5x175mm ..... 1

### 68



 **注意**  
**Caution**

先将卡簧卡住定位轴一头，待整体支撑臂安装无误后，再来卡另一头卡簧。  
First the reed stuck in the positioning shaft head, until the overall support arm installation is correct, and then card the other end of the reed.

-  ..... 8  
W05011 HM  $\varnothing$ 2x10MM
-  ..... 8  
LS020 M2

### 69

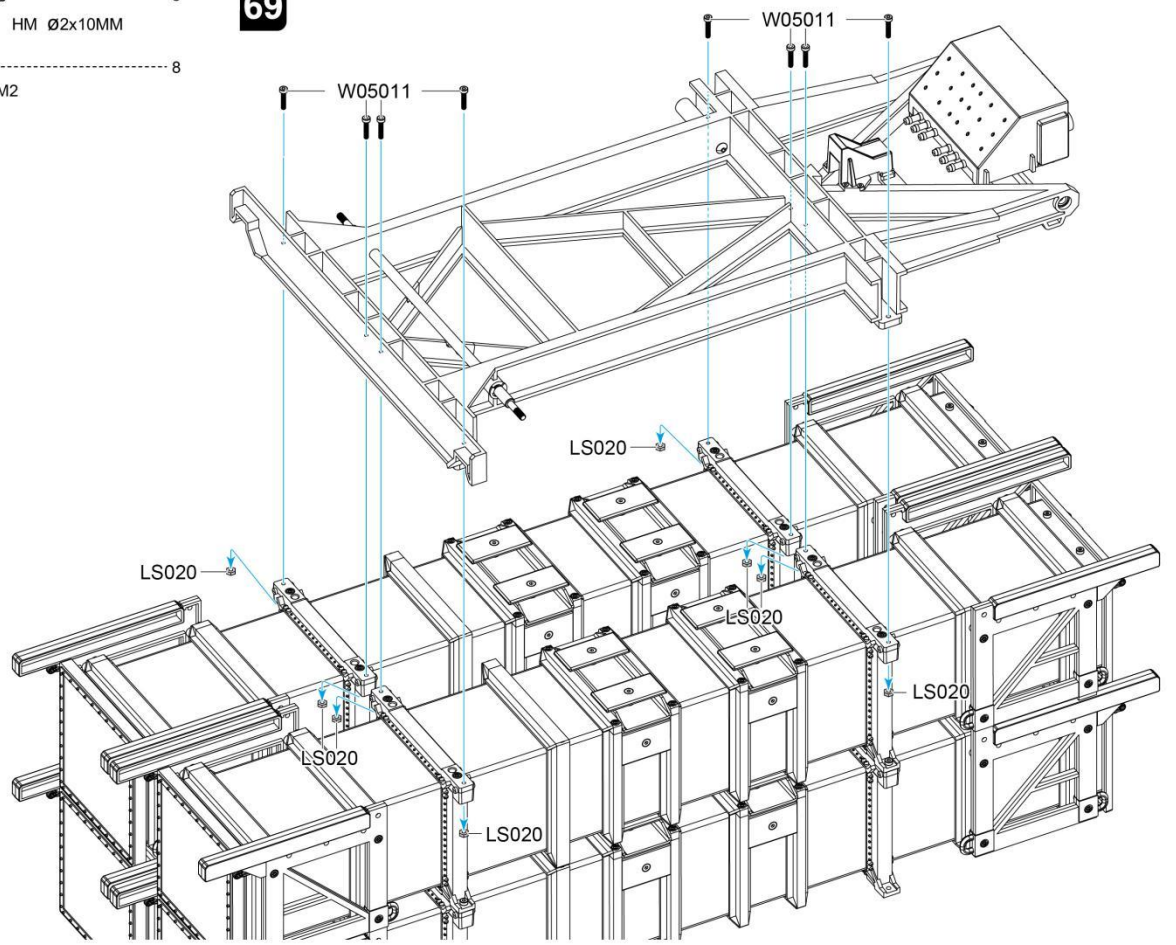

-  1  
LSKB-05 KB Ø2x5MM
-  4  
LS100 TM Ø2x6MM

**70**

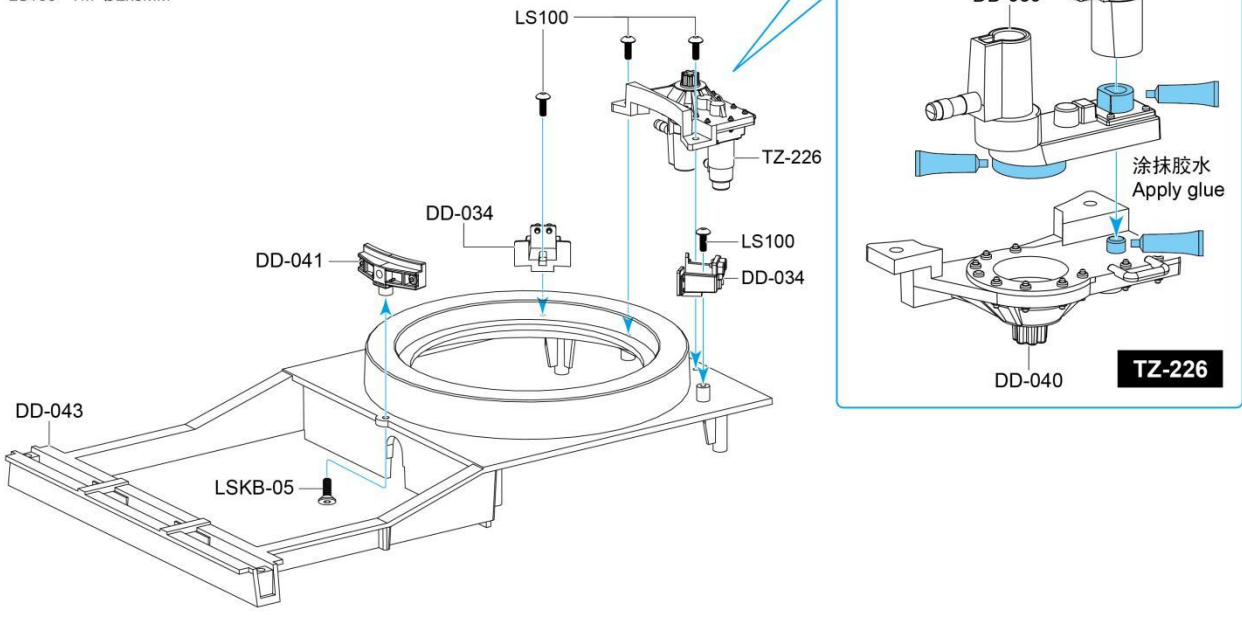

-  8  
G10611 KM Ø2.5x6MM

**71**

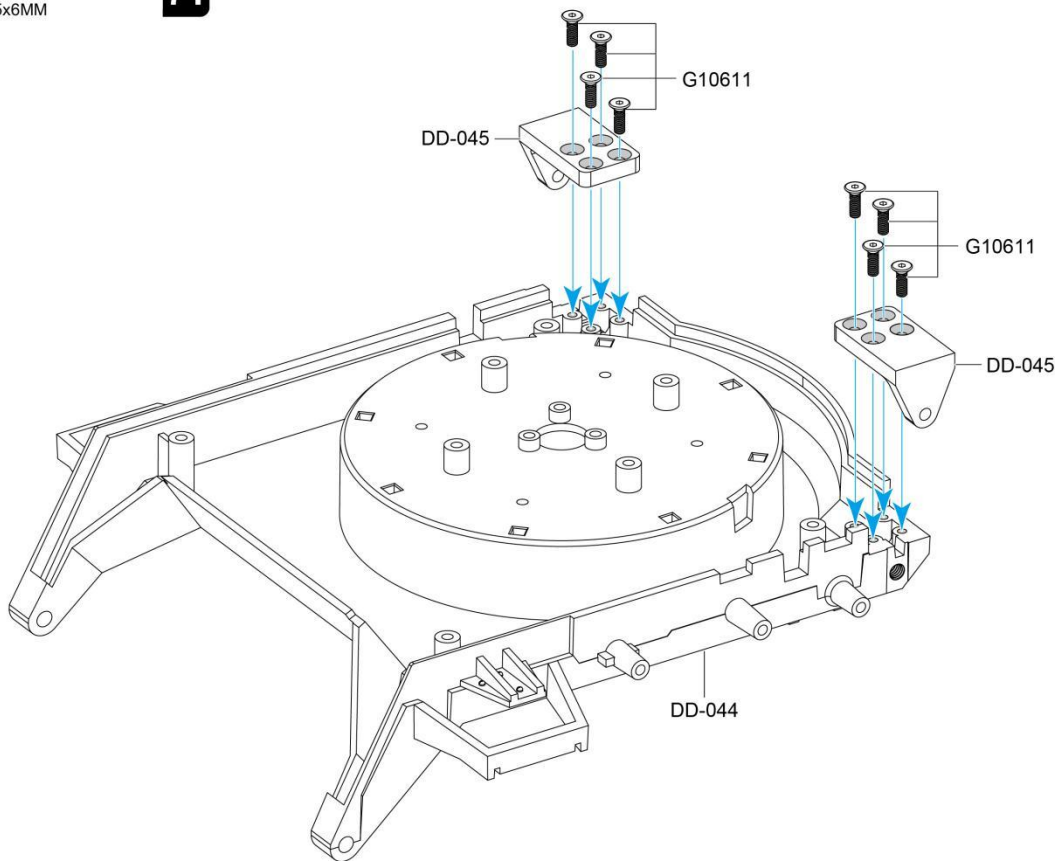

- ④ ----- 4  
P001 KM  $\varnothing 3 \times 8 \text{MM}$
- ③ ----- 3  
LS001 TM  $\varnothing 3 \times 6 \text{MM}$
- ① ----- 1  
XC-105-6 6路导电滑环  
6-way conductive slip ring

**72**

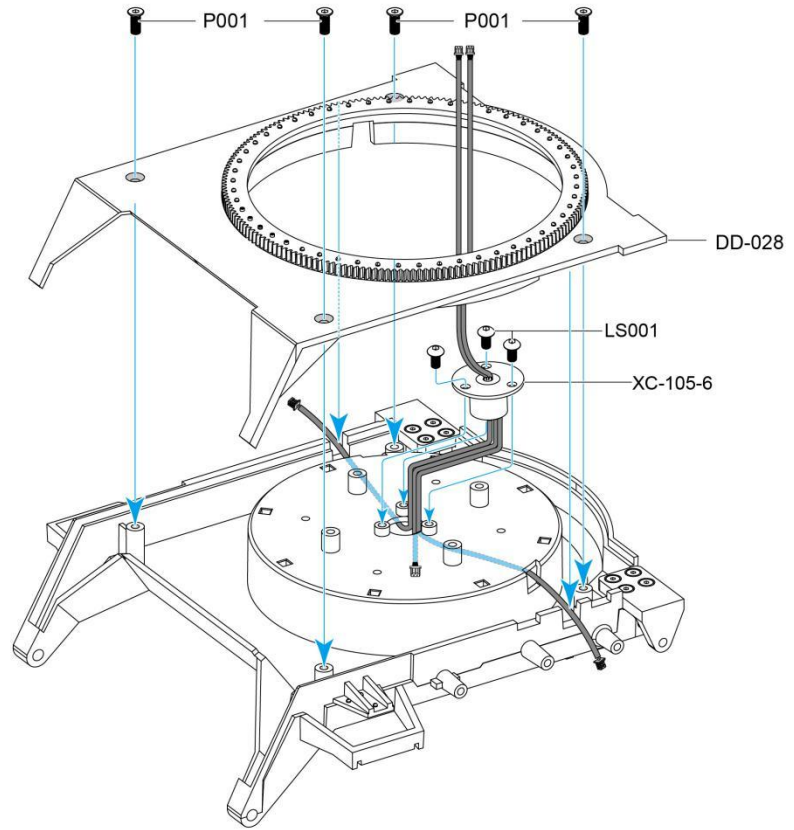

- ⑧ ----- 8  
W141  $\varnothing 3 \text{mm}$

**73**

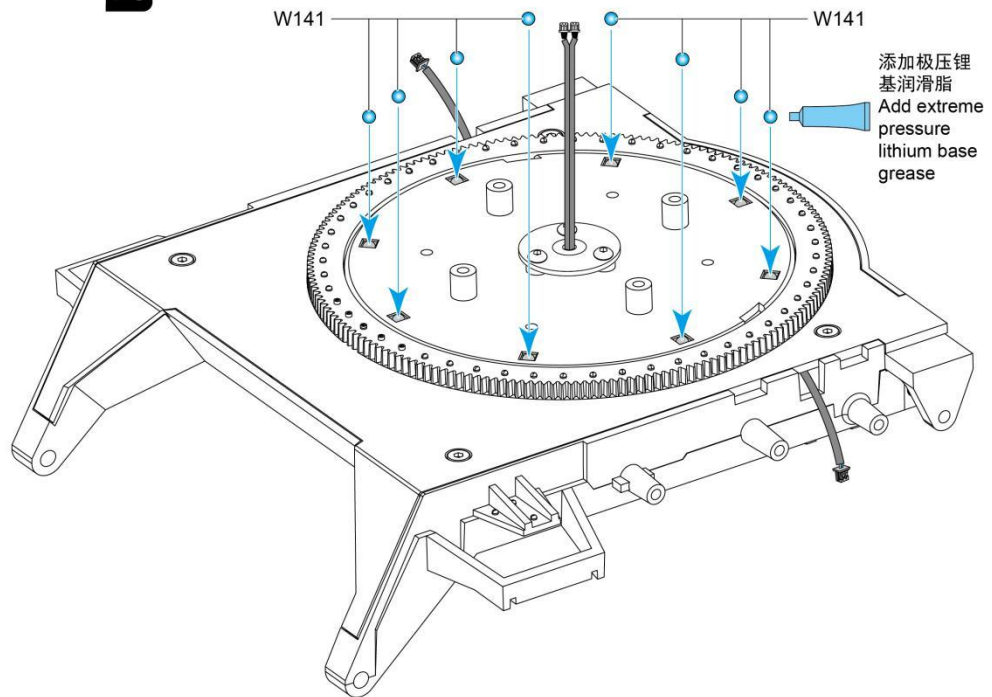



LS001 TM Ø3x6MM

74

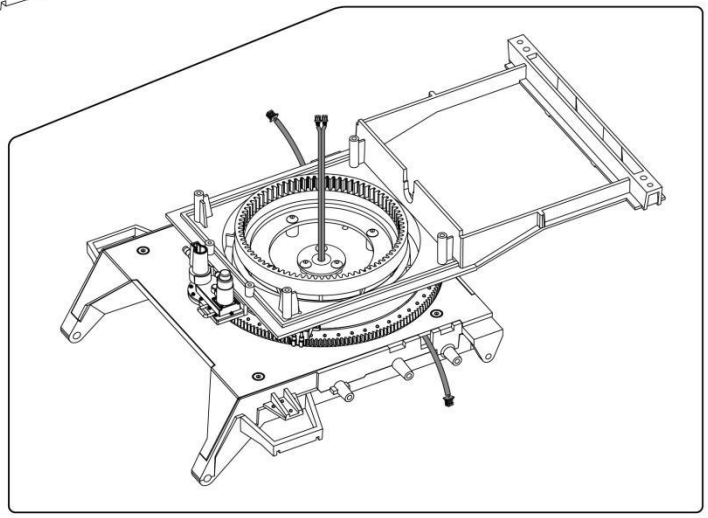
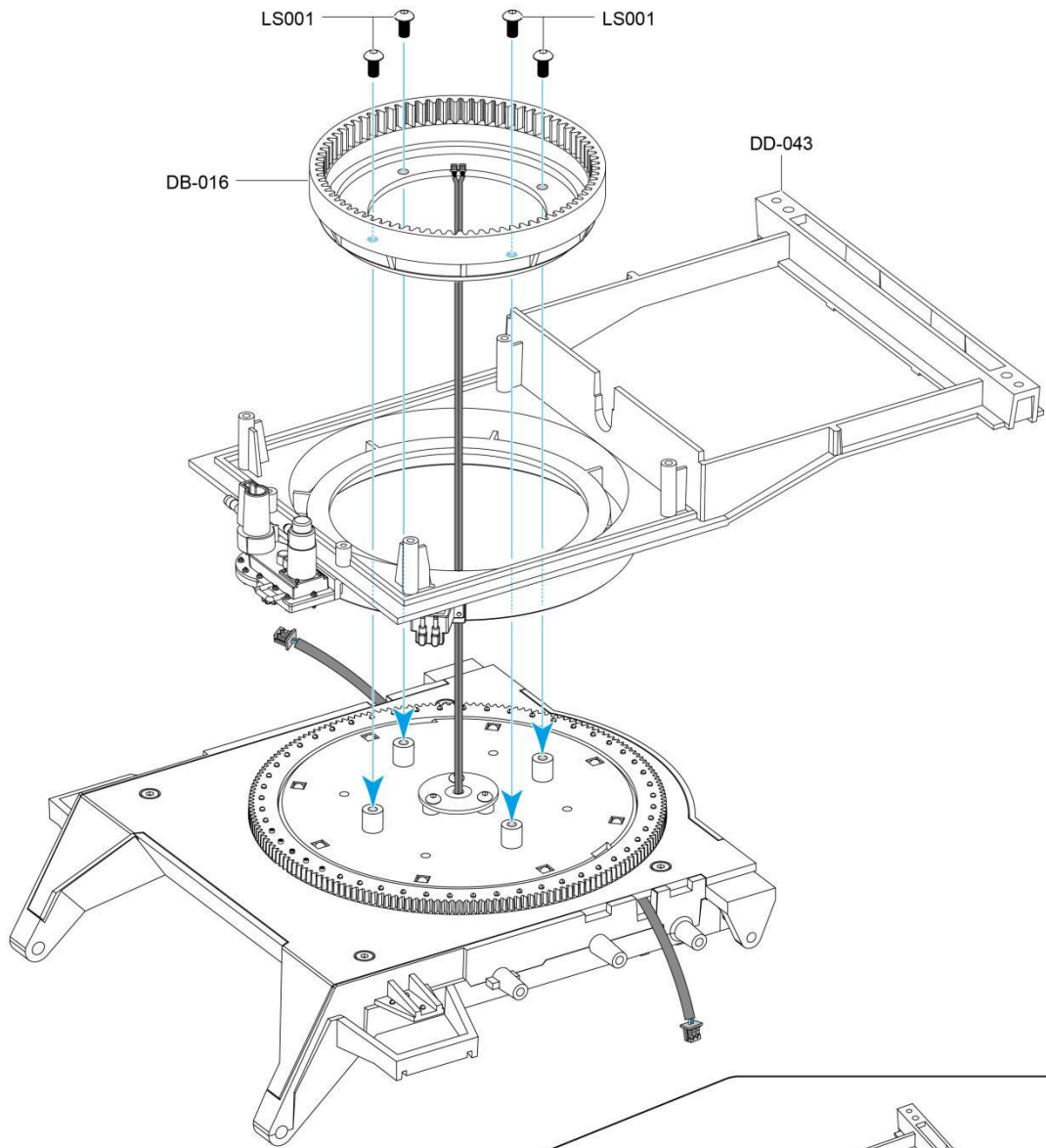

- ④ ..... 4  
LS001 TM Ø3x6MM
- ① ..... 1  
LS831 Ø4x4MM

**75**

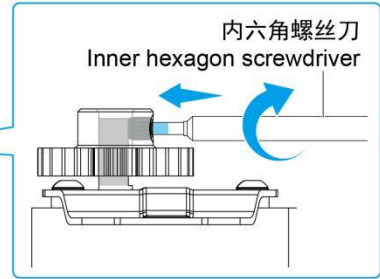
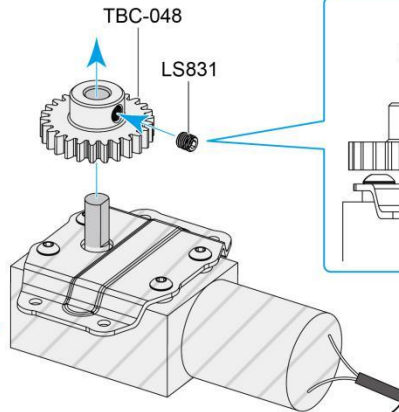
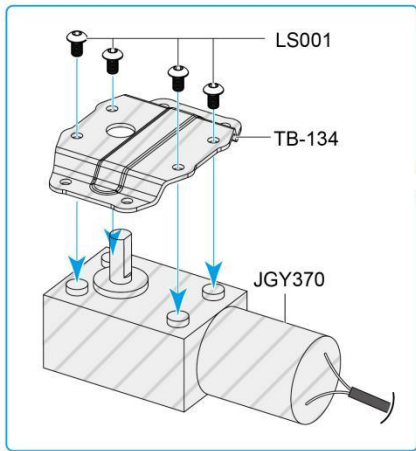

此配件出厂时已组装完成，组装图只是提供组装过程，可用于维护配件。  
This accessory was assembled at the factory, and the assembly diagram simply provides the assembly process, can be used to maintain accessories.

- ④ ..... 4  
LS001 TM Ø3x6MM

**76**

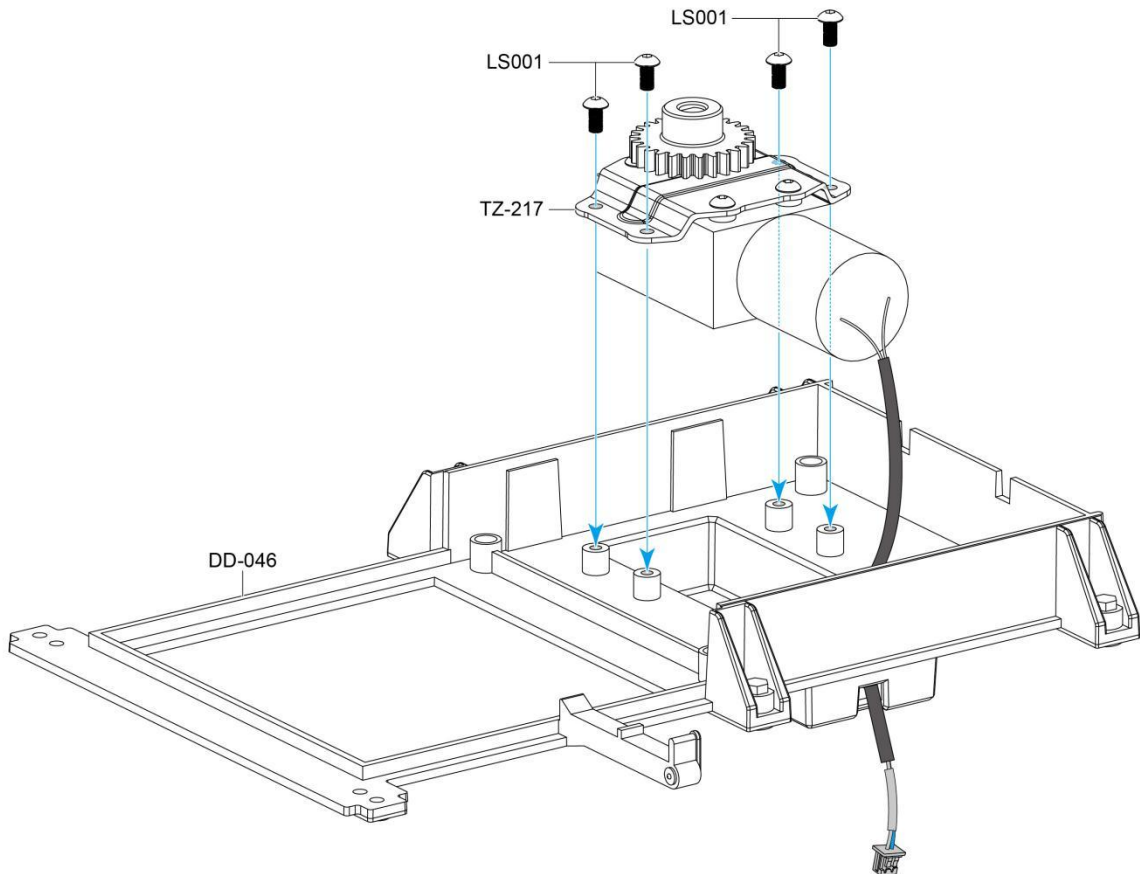

W05012 HM Ø2.5x6MM 4

77

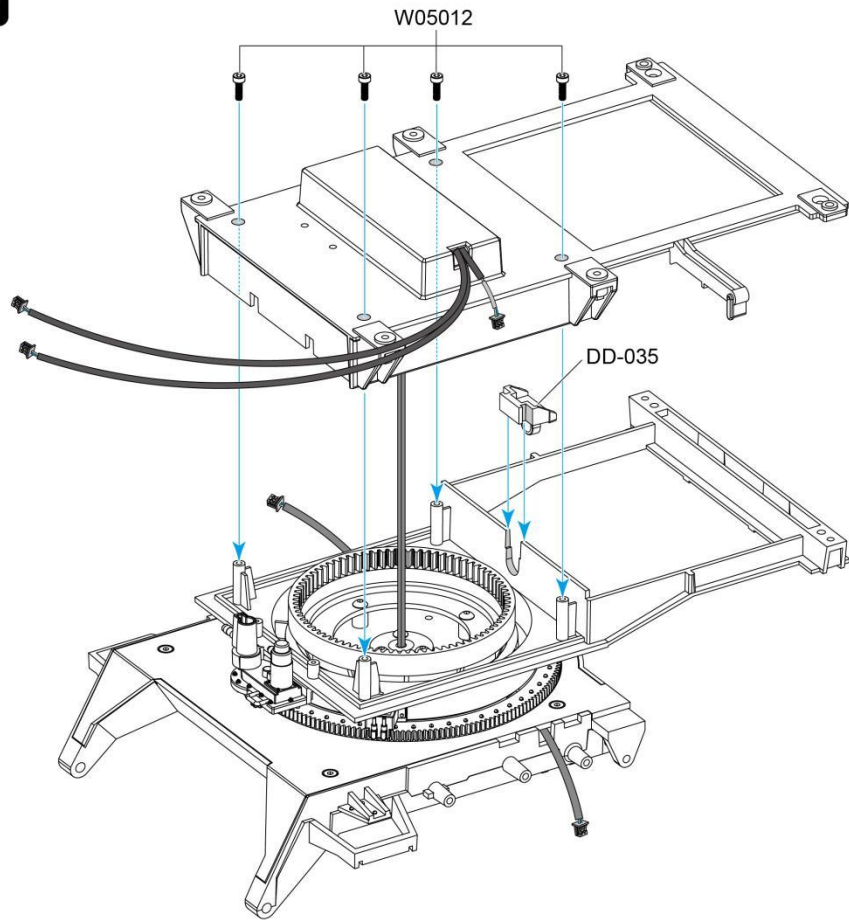

LSTB-310 TB Ø3x10MM 2

78

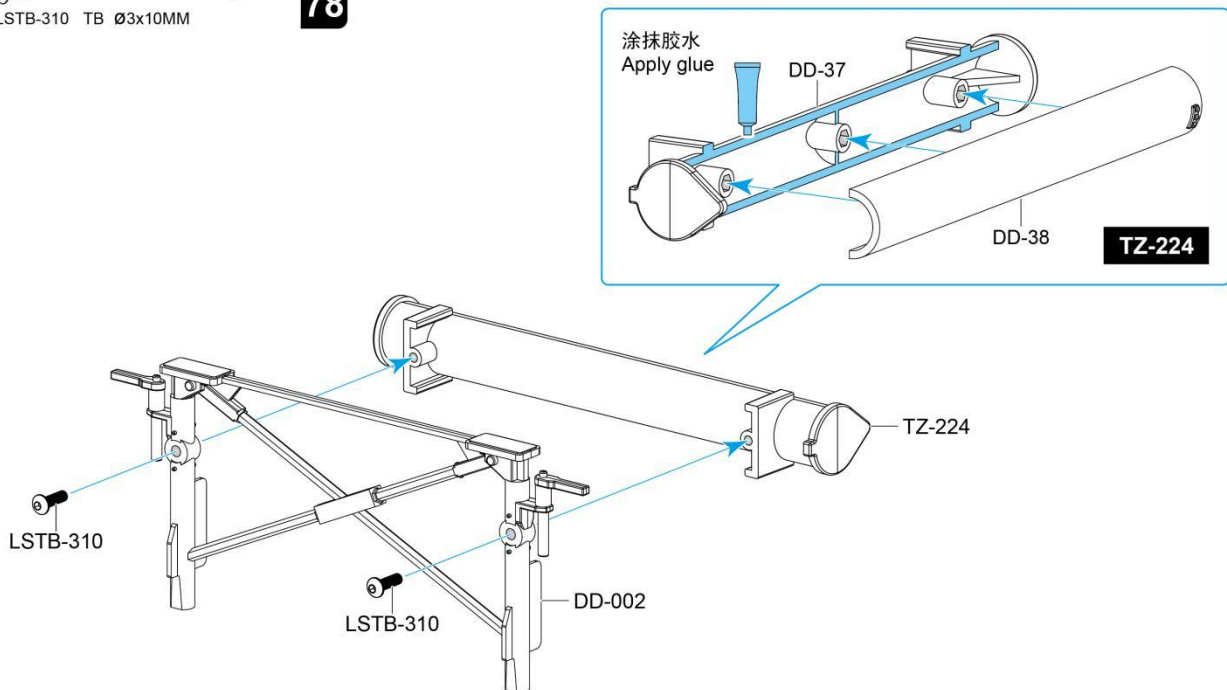

**特别提示:**  
Especially prompt

这一步骤是导弹支撑架的安装，由于会影响到导弹旋转角度，所以这一部件可以先不加螺丝固定。当导弹放下时，再手动放置该支撑架来限位导弹发射塔的下降低度。  
This step is the installation of the missile support frame. Since the rotation angle of the missile will be affected, this part can be fixed without screws. When the missile is lowered, the support frame is manually placed to limit the descending angle of the missile launching tower.

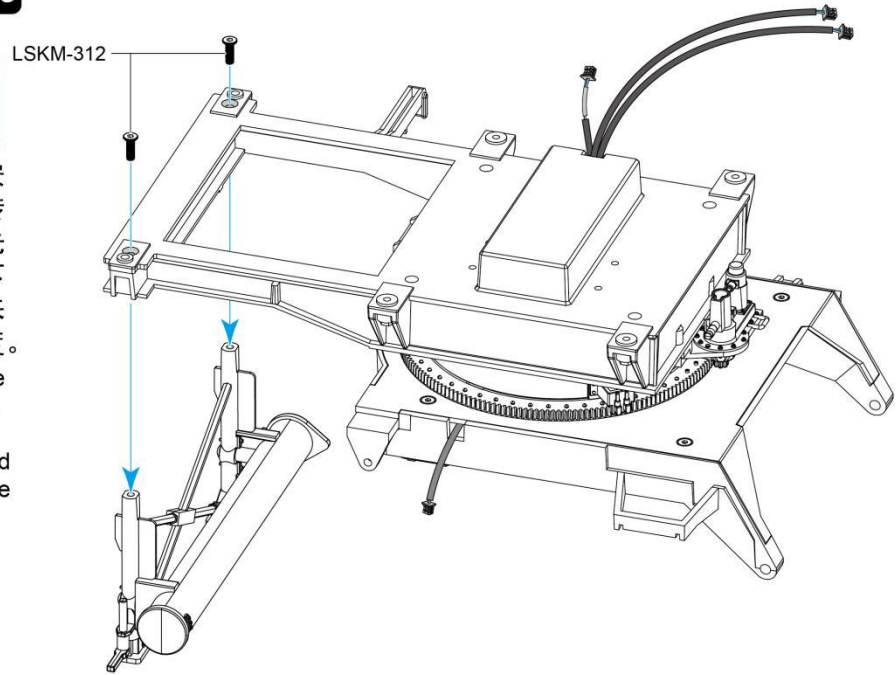

**注意**  
Caution

M4 为5V电压输出，属于多余端口，无需理会，请不要随意私接电源或擅自改装。  
M4 is a 5V voltage output, which is a redundant port. Don't bother about it. Please don't connect the power supply privately or modify it without authorization.

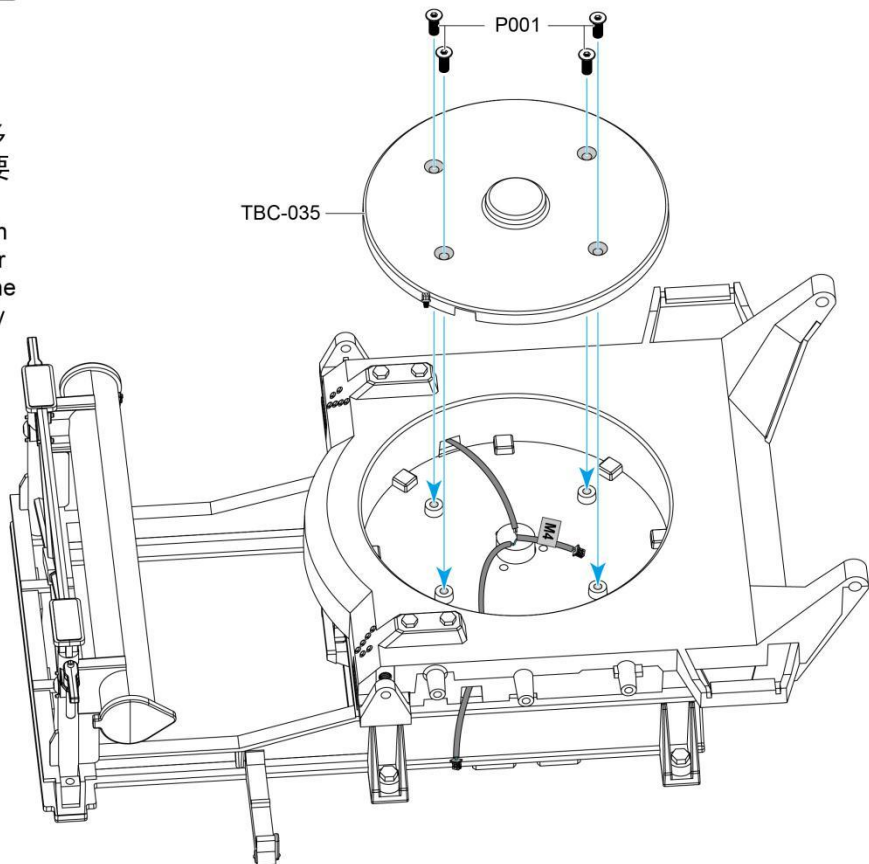

W05014 HM  $\varnothing 3 \times 8 \text{MM}$  2

81

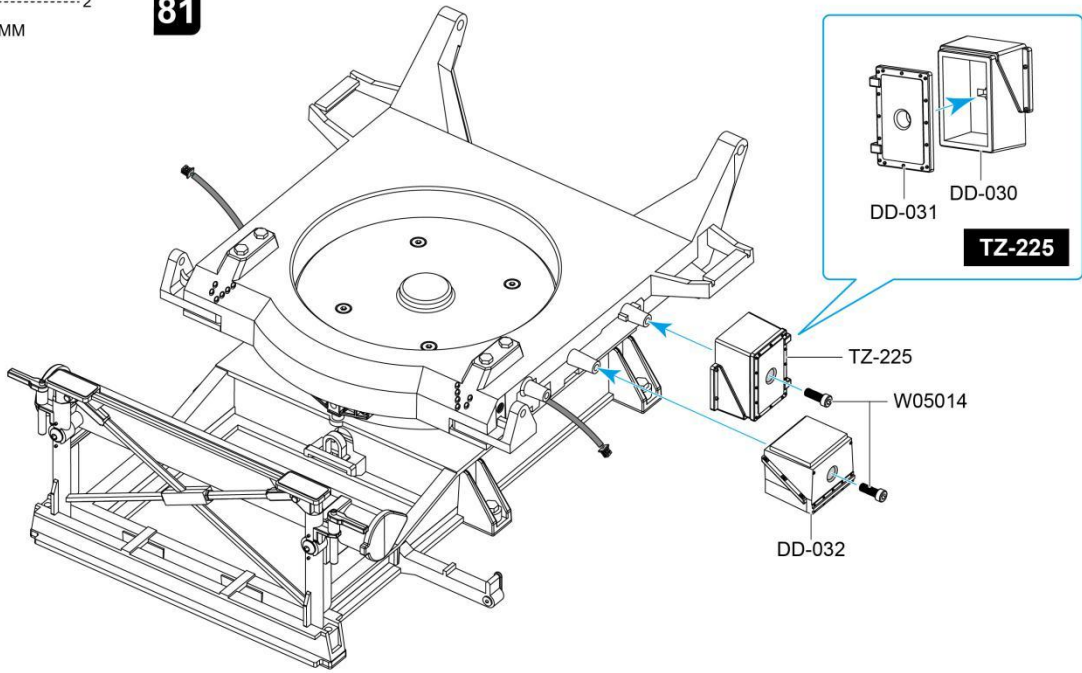

W05021 TM  $\varnothing 3 \times 25 \text{MM}$  1

A1-002  $\varnothing 3.1 \times \varnothing 5 \times 13 \text{mm}$  1

C013  $\varnothing 3.1 \times \varnothing 5 \times 5 \text{mm}$  2

804-5-055  $\varnothing 3.5 \times 70 \text{mm}$  1

82

70 mm

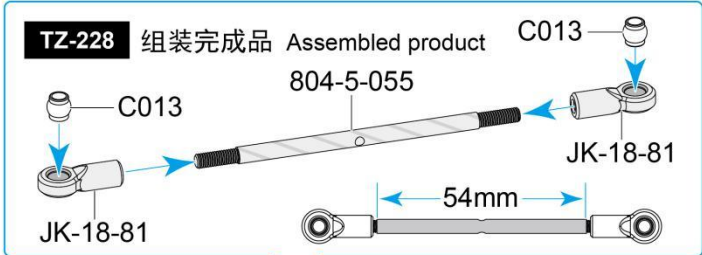

**注意**  
**Caution**

此配件出厂时已组装完成，组装图只是提供组装过程，可用于维护配件。  
This accessory was assembled at the factory, and the assembly diagram simply provides the assembly process, can be used to maintain accessories.

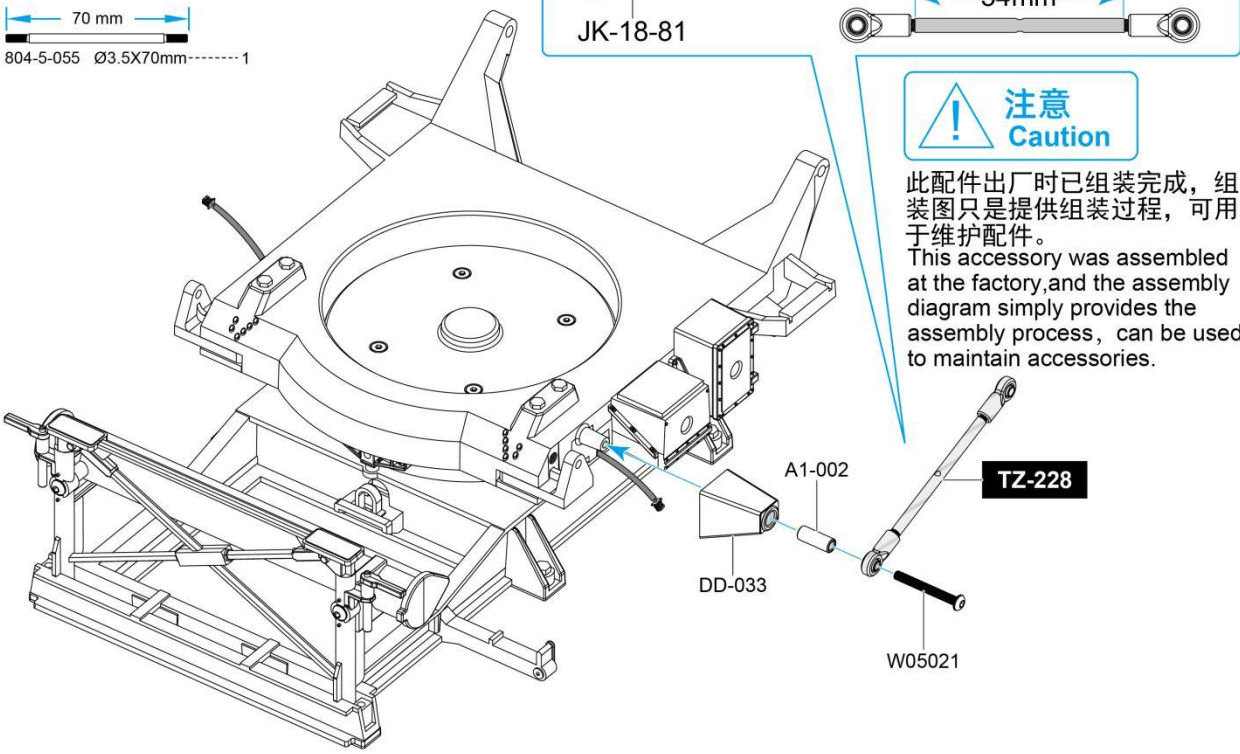

# 83

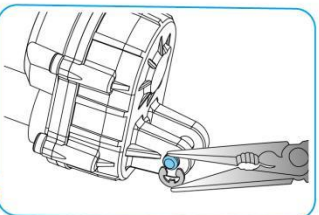
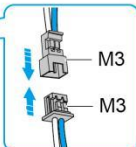
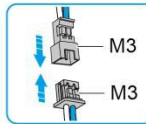
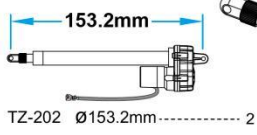

提示：此步骤安装完成后先测试，  
确认功能正常后再安装卡簧。  
Tip: After this step is installed,  
test it first, and then install the  
circlip after confirming that the  
function is normal.

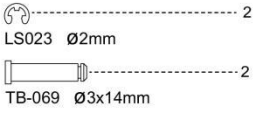

# 84

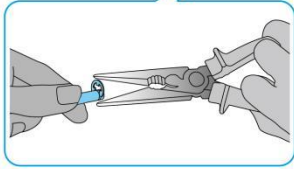
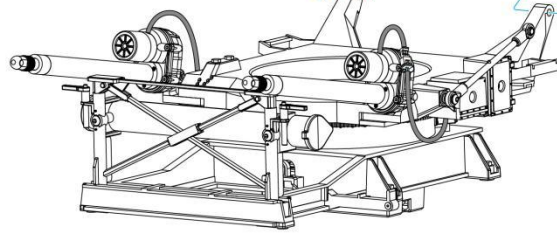
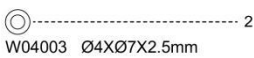
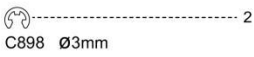
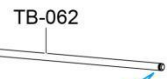
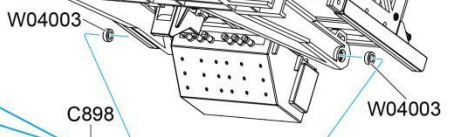
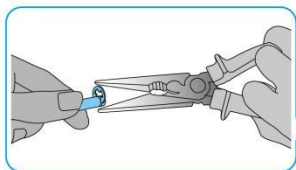
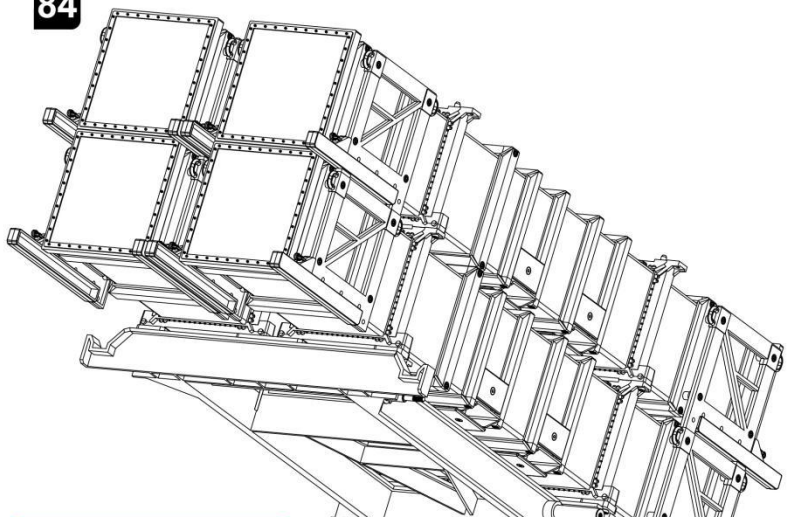

85

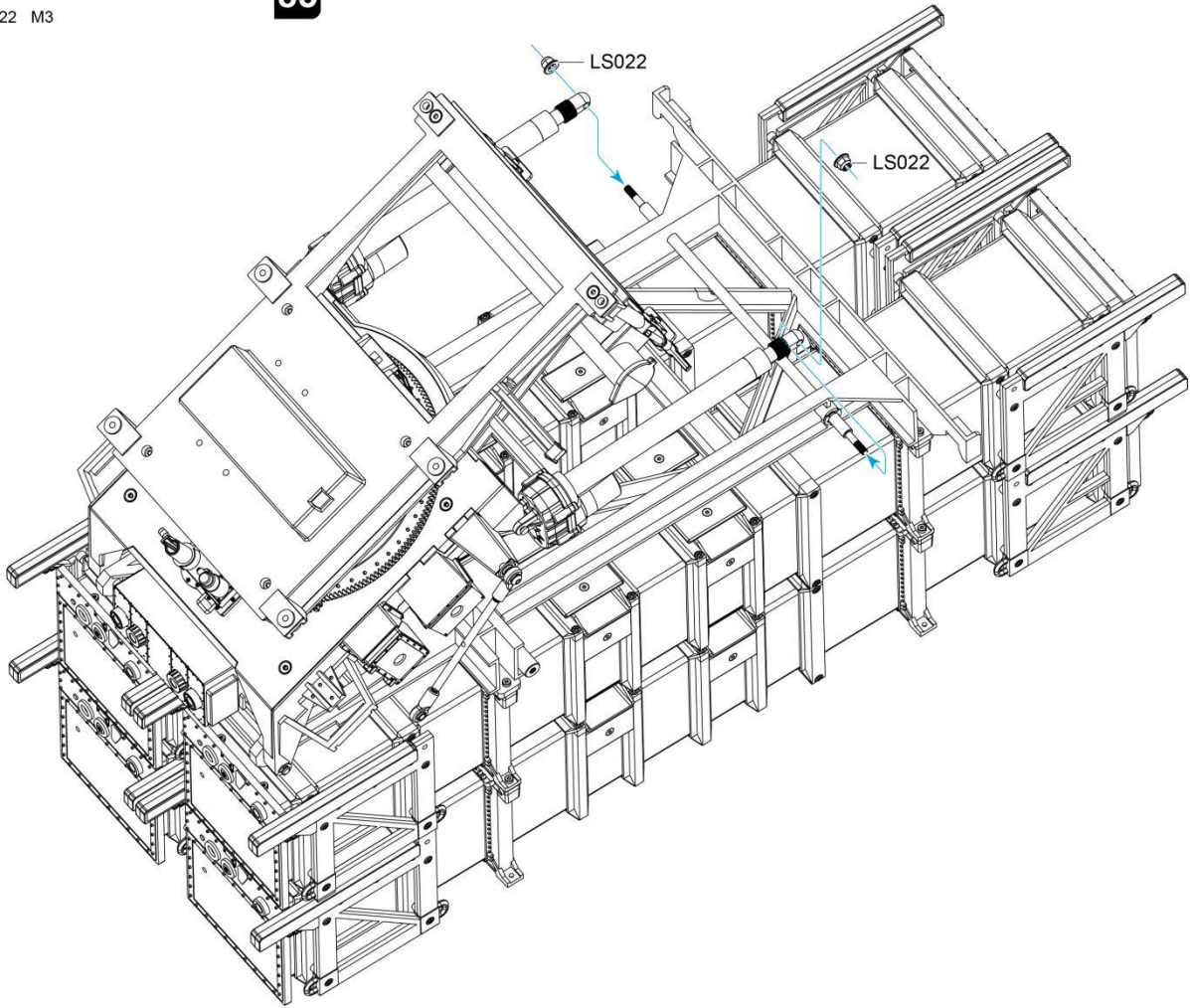

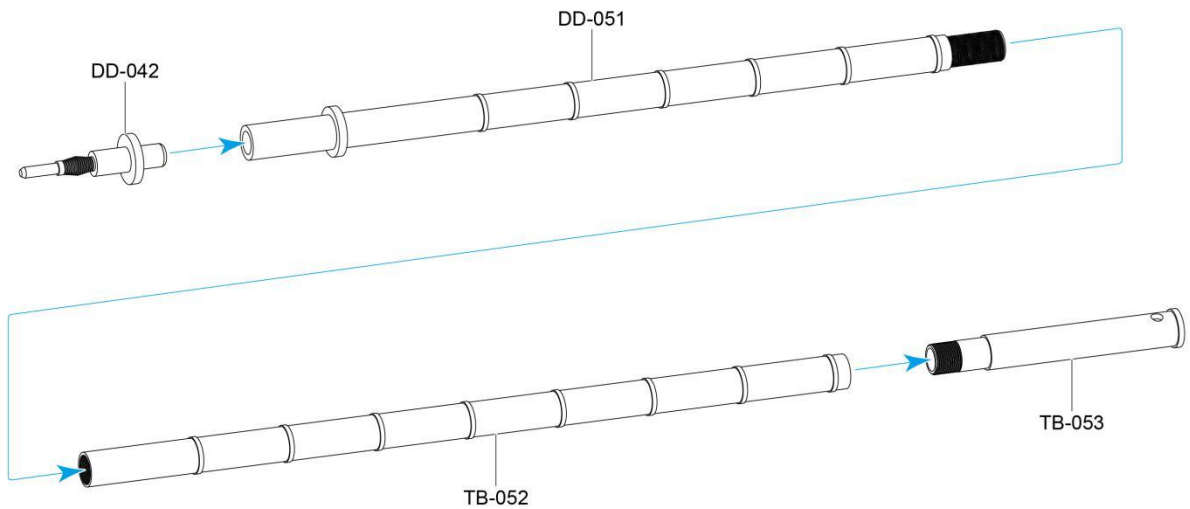

86

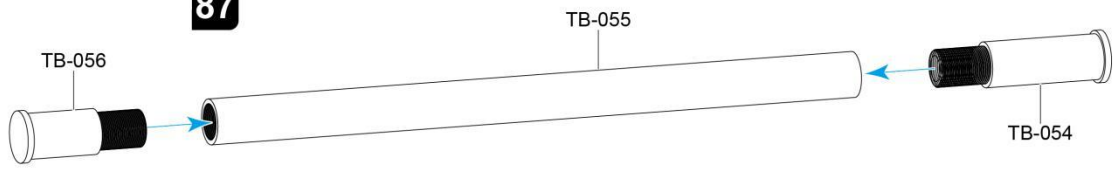

87



-  ..... 2  
P001 KM Ø3x8MM
-  ..... 1  
W05019 TM Ø3x12MM
-  ..... 1  
CU-001 TM Ø5x6.5MM

88

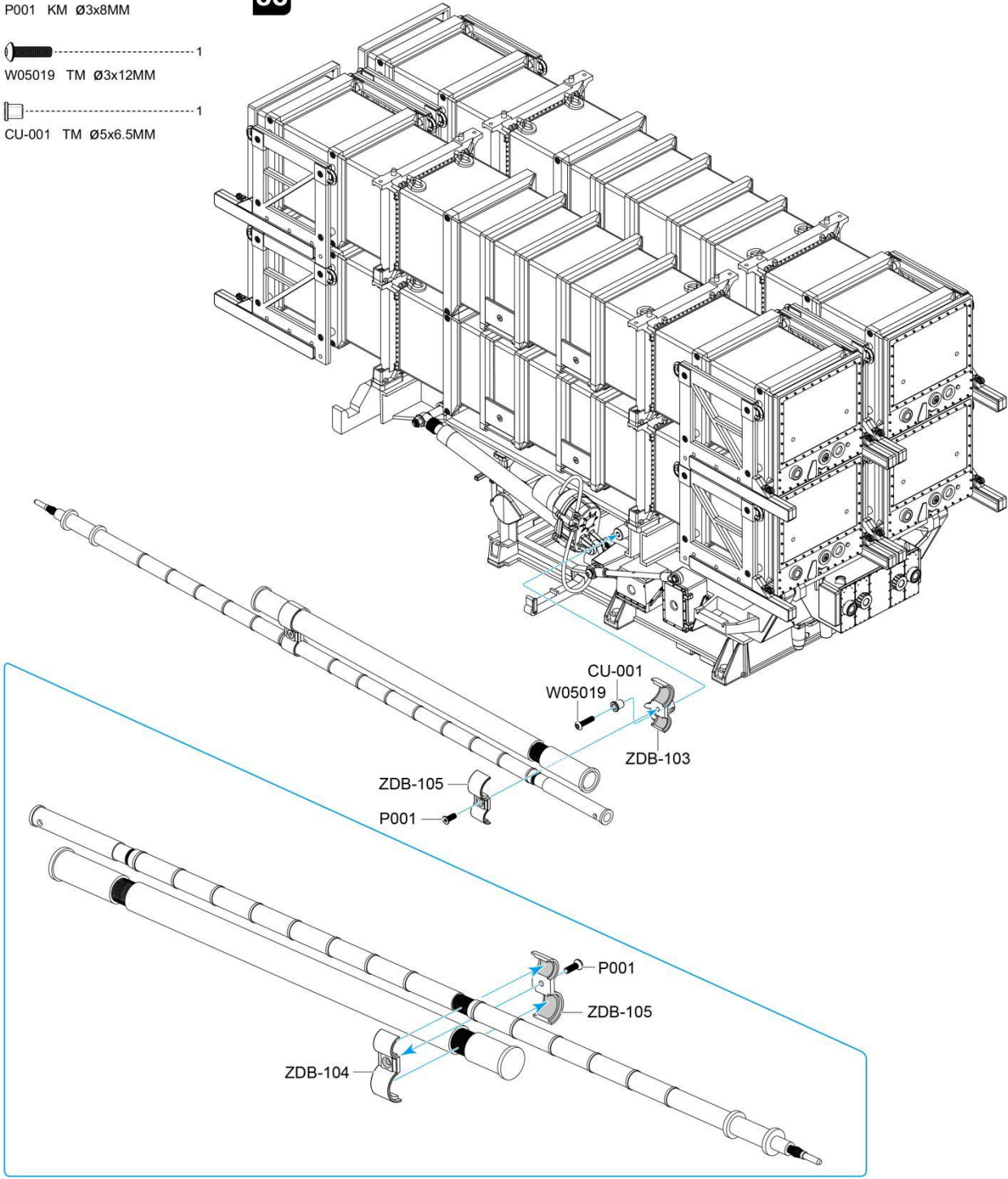





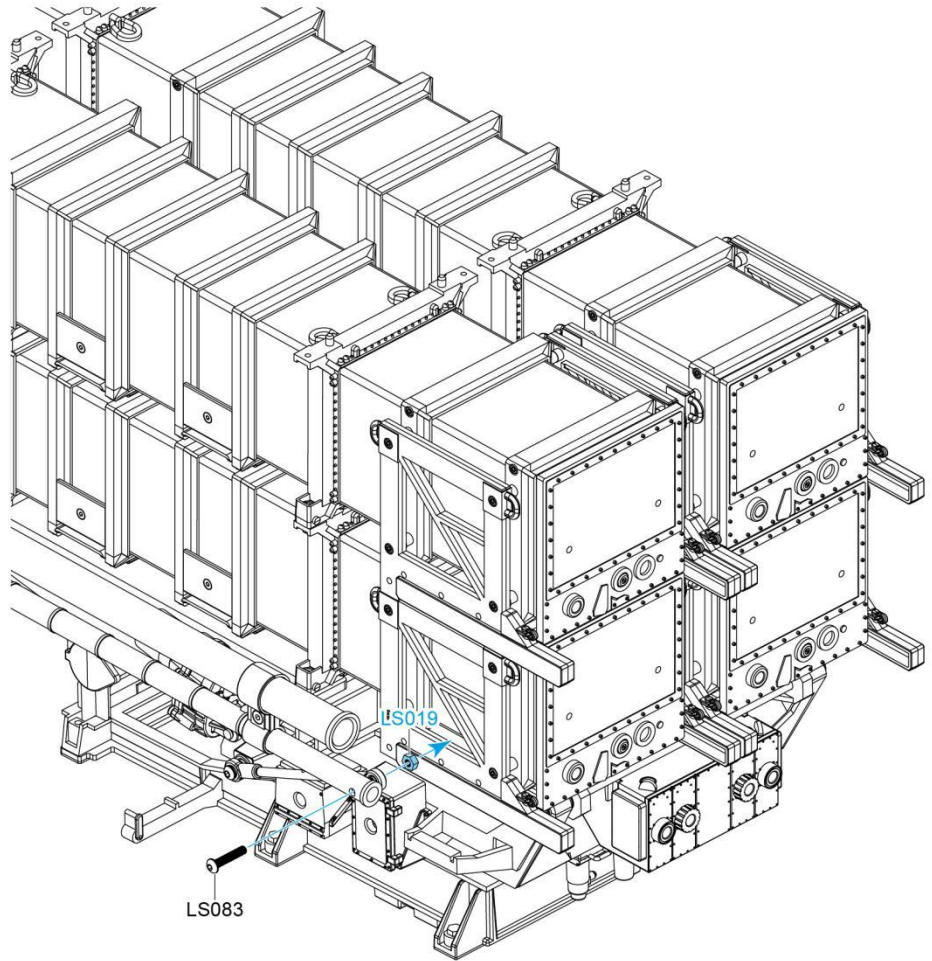

-  ..... 1  
LS083 TM Ø3x16mm
-  ..... 1  
LS019 M3



**89**

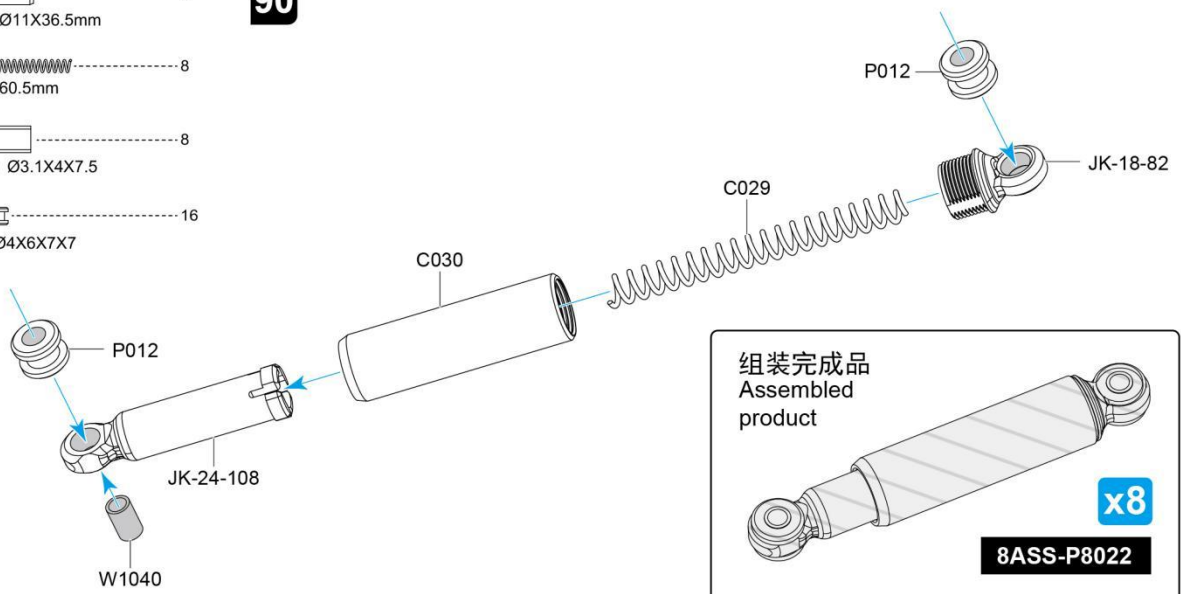

-  ..... 8  
C030 Ø11X36.5mm
-  ..... 8  
C029 60.5mm
-  ..... 8  
W1040 Ø3.1X4X7.5
-  ..... 16  
P012 Ø4X6X7X7

**90**



-  4  
TB-202  $\varnothing 2.5 \times 40 \text{mm}$
-  8  
C013  $\varnothing 3.1 \times \varnothing 5 \times 5 \text{mm}$

**91**



此配件出厂时已组装完成，组装图只是提供组装过程，可用于维护配件。  
This accessory was assembled at the factory, and the assembly diagram simply provides the assembly process, can be used to maintain accessories.

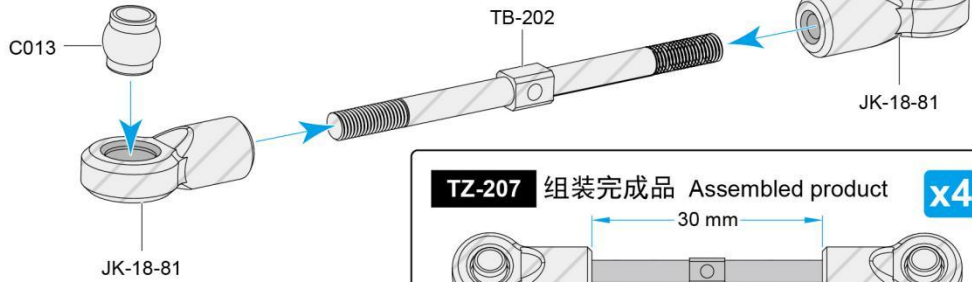

**TZ-207** 组装完成品 Assembled product **x4**

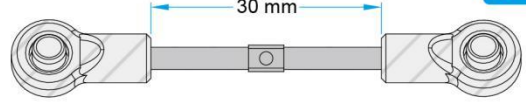

-  6  
LSKB-2612 KB  $\varnothing 2.6 \times 12 \text{mm}$
-  4  
W1037  $\varnothing 3 \times \varnothing 5 \times 3 \text{mm}$

**92**



此配件出厂时已组装完成，组装图只是提供组装过程，可用于维护配件。  
This accessory was assembled at the factory, and the assembly diagram simply provides the assembly process, can be used to maintain accessories.

**8ASS-P0024**

组装完成品  
Assembled product

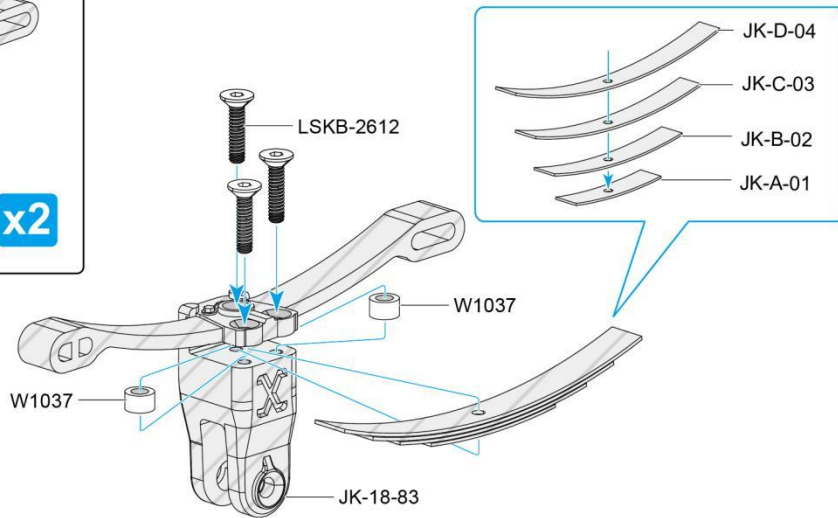
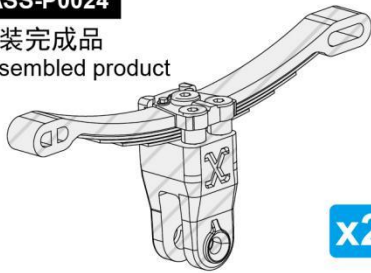



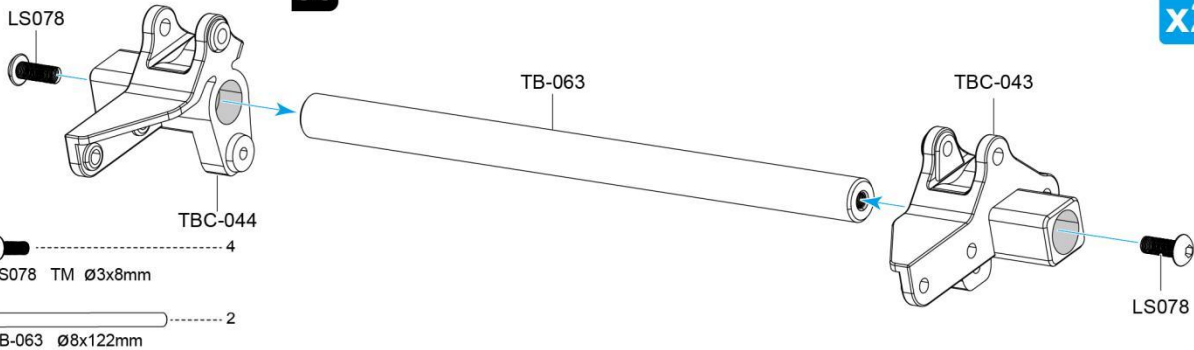

**93**

**x2**



-  4  
LS078 TM  $\varnothing 3 \times 8 \text{mm}$
-  2  
TB-063  $\varnothing 8 \times 122 \text{mm}$

-  ..... 2  
LS078 TM Ø3x8mm
-  ..... 4  
W05007 TM Ø3x14MM
-  ..... 4  
TB-201 42mm
-  ..... 8  
LS225 Ø5XØ9X3mm
-  ..... 4  
LS15003 Ø5.1XØ7X0.4mm

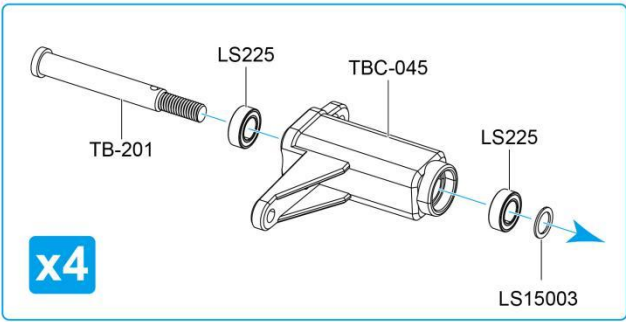
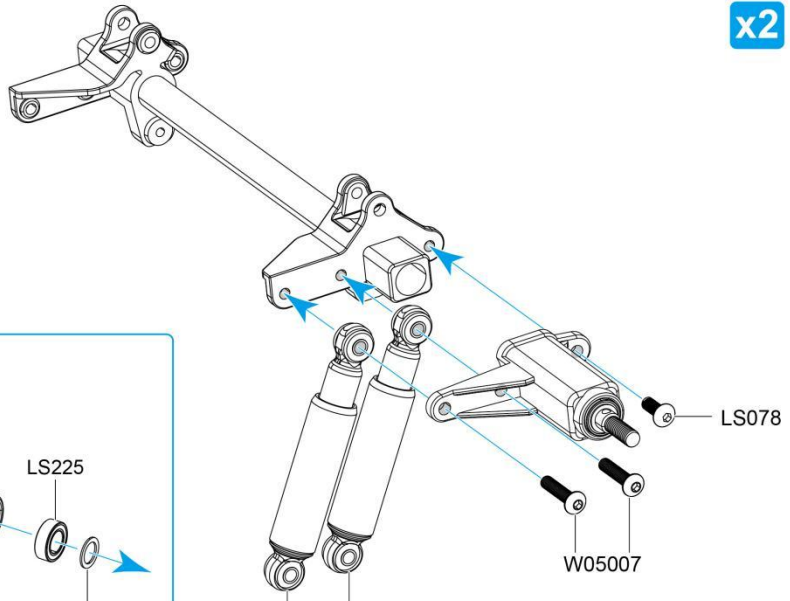

**94**

**x2**



**x4**

**8ASS-P8022**

-  ..... 2  
LS078 TM Ø3x8mm
-  ..... 4  
W05007 TM Ø3x14MM

**95**

**x2**

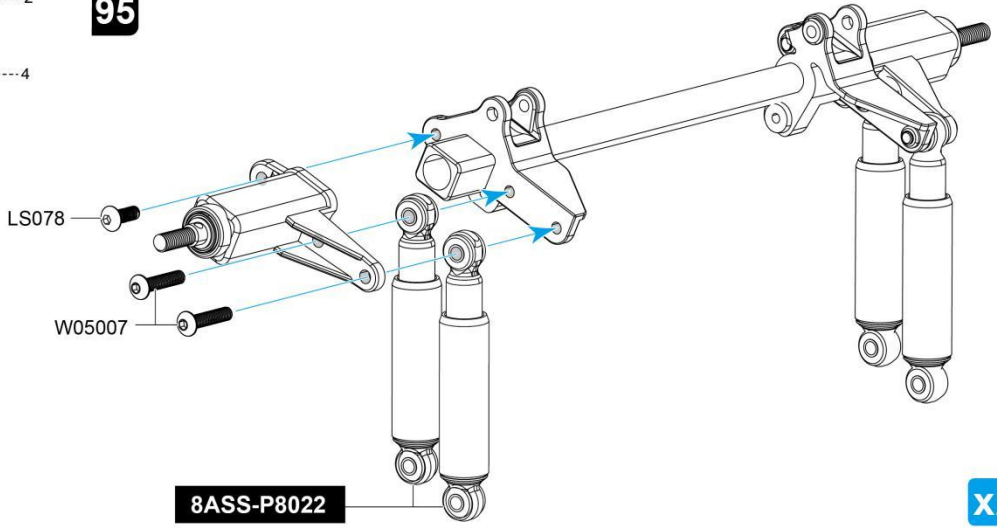

**8ASS-P8022**

-  ..... 4  
W05019 TM Ø3x12MM

**96**

**x2**

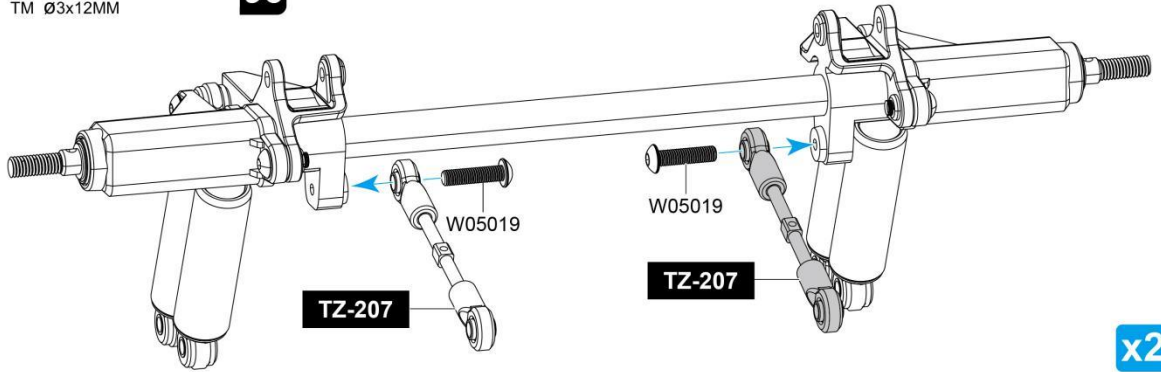



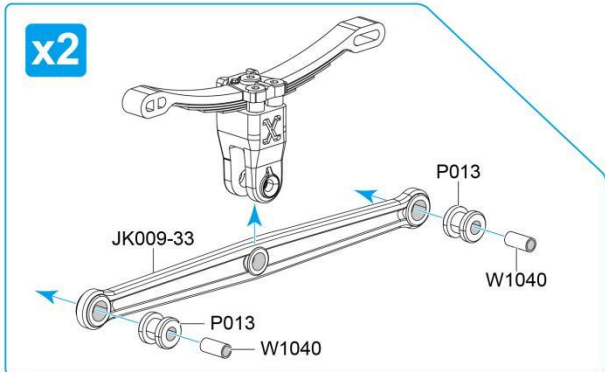
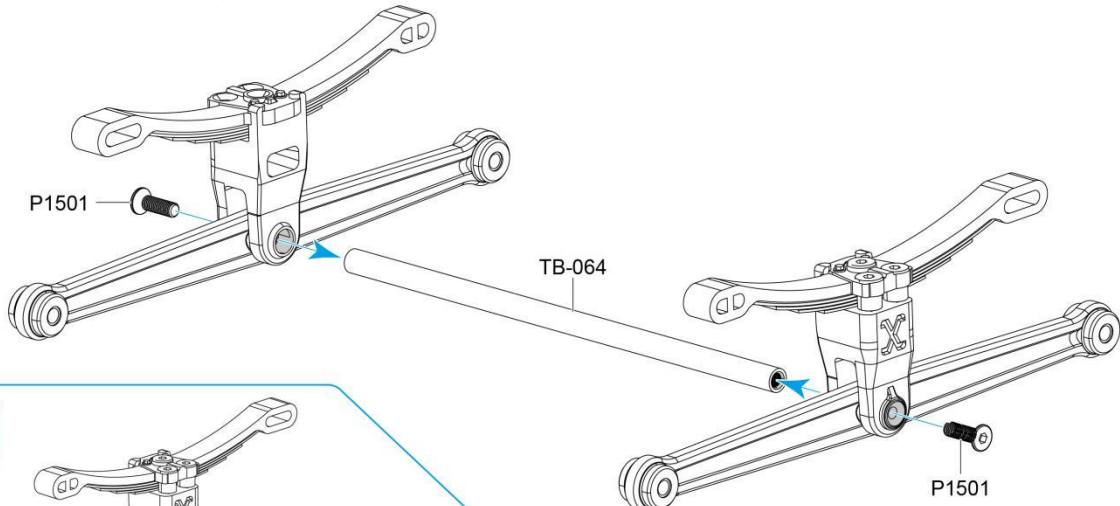

**TZ-207**

**TZ-207**

97





-  ..... 2  
P1501 KM Ø3x10MM
-  ..... 1  
TB-064 Ø5x120.7mm
-  ..... 4  
P013 Ø4X6X9X9
-  ..... 4  
W1040 Ø3.1xØ4x7.5mm

-  ..... 4  
LS083 TM Ø3x16mm

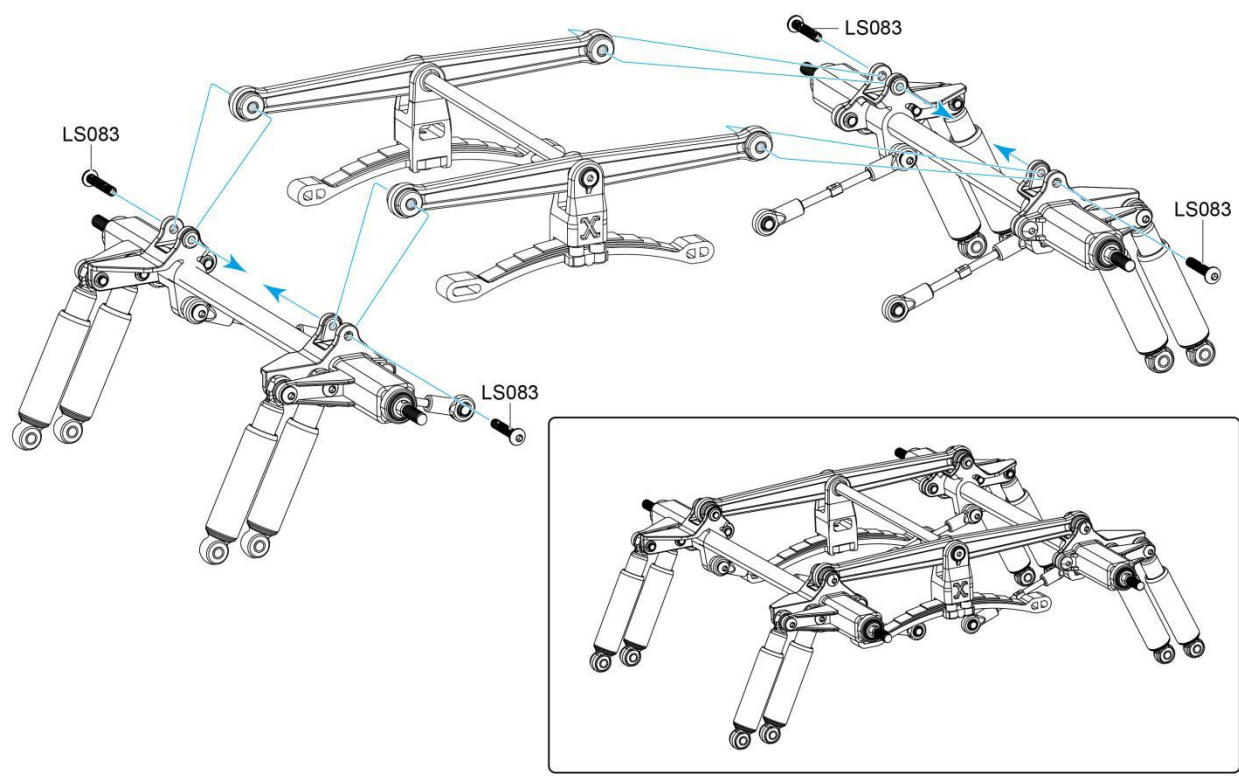
98



-  ..... 4  
W05001 M4
-  ..... 4  
W01003 Ø2x10mm
-  ..... 4  
JK009-34 12mm

**99**

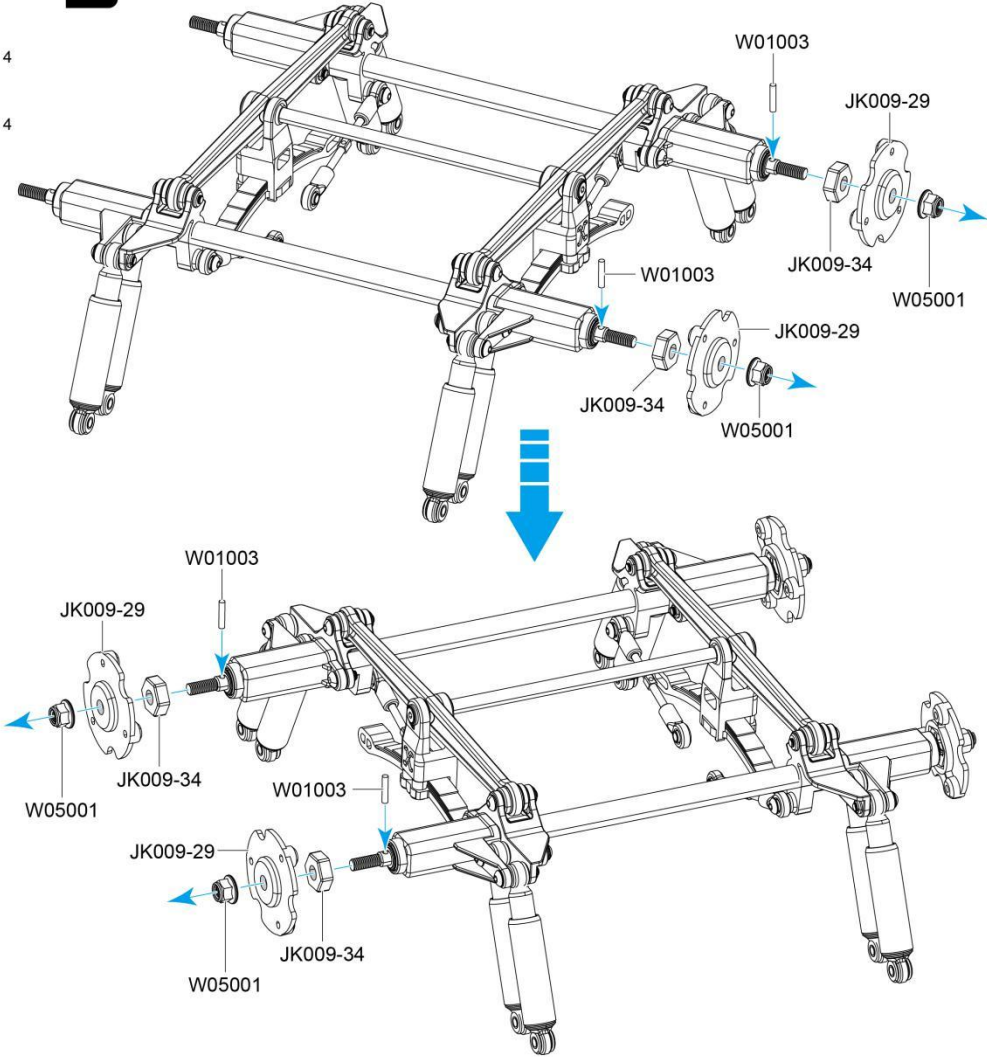

-  ..... 8  
TB-8058 Ø6.5X10.5mm

**100**

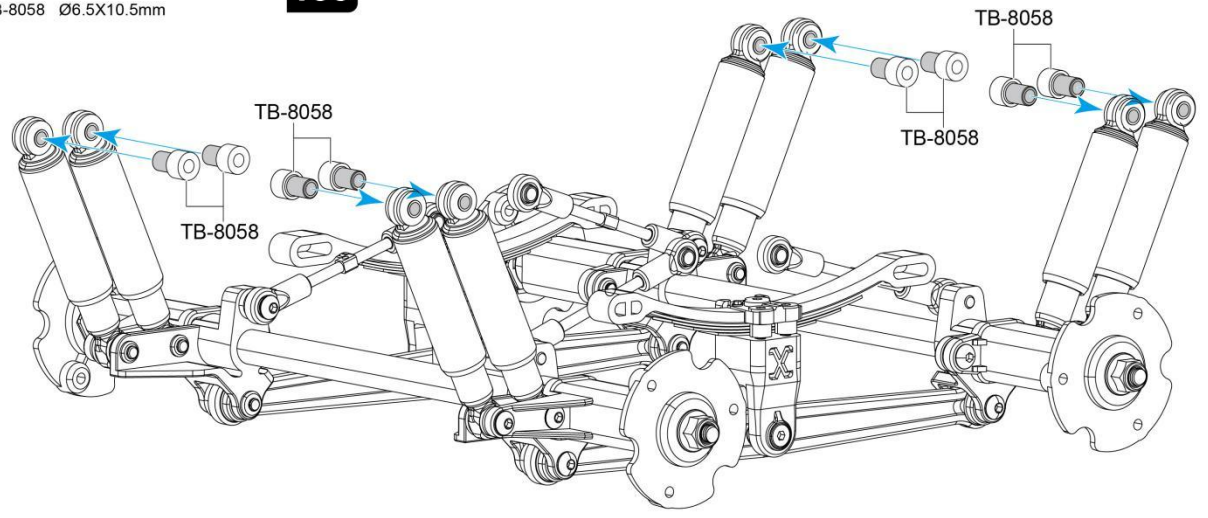

-  ..... 2  
LS001 TM Ø3x6MM
-  ..... 4  
W05016 KM Ø2x6mm

**101**

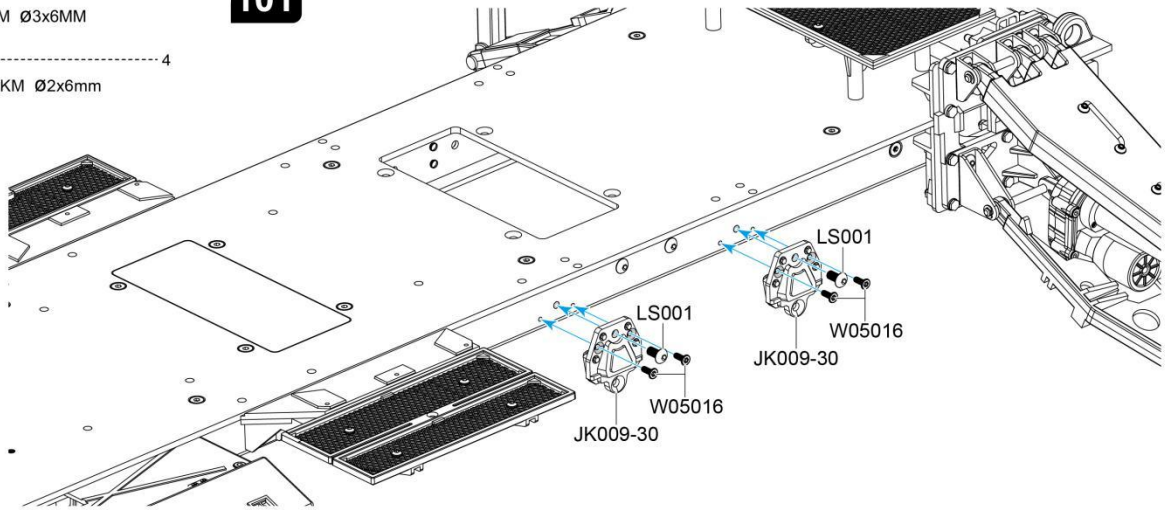

**102**

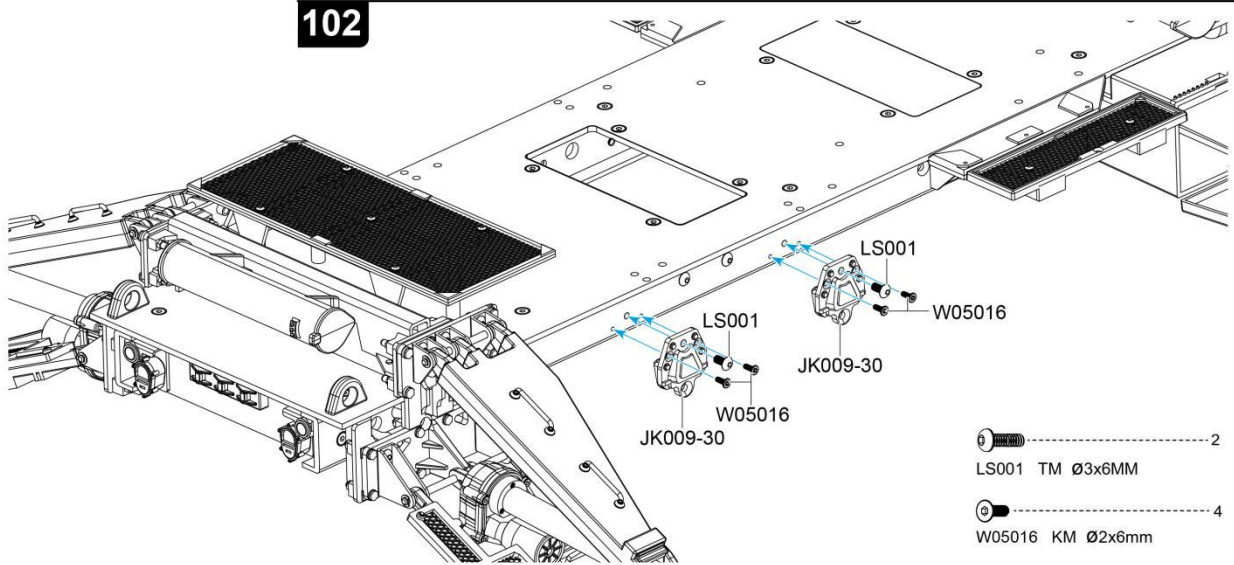

-  ..... 2  
LS001 TM Ø3x6MM
-  ..... 4  
W05016 KM Ø2x6mm

-  ..... 14  
LSPM-153 KB Ø1.5x3MM
-  ..... 4  
LSZ-01544 KB Ø2x4MM

**103**

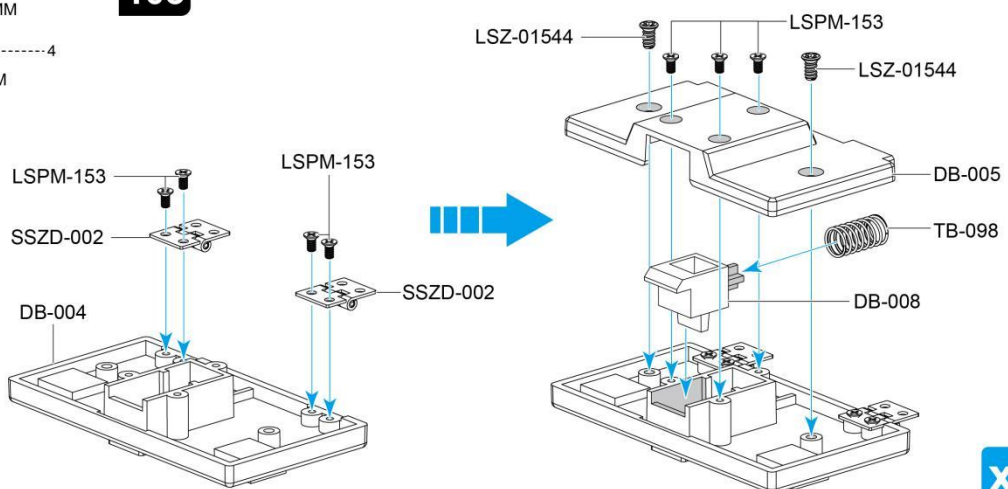

**x2**

104

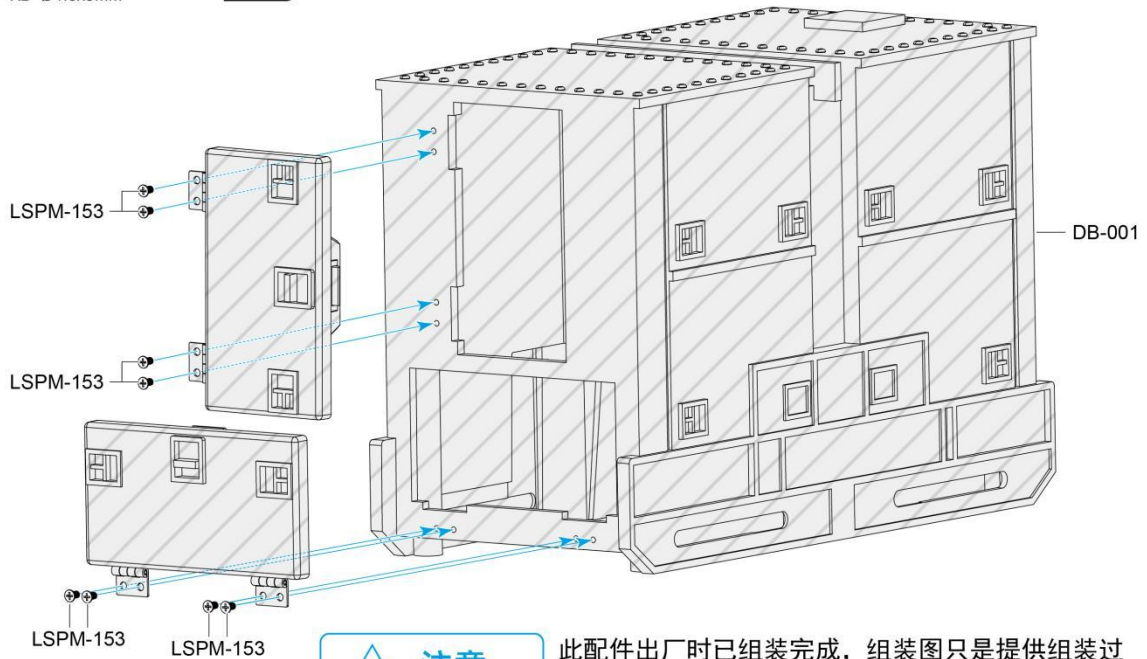

此配件出厂时已组装完成，组装图只是提供组装过程，可用于维护配件。  
This accessory was assembled at the factory, and the assembly diagram simply provides the assembly process, can be used to maintain accessories.

105

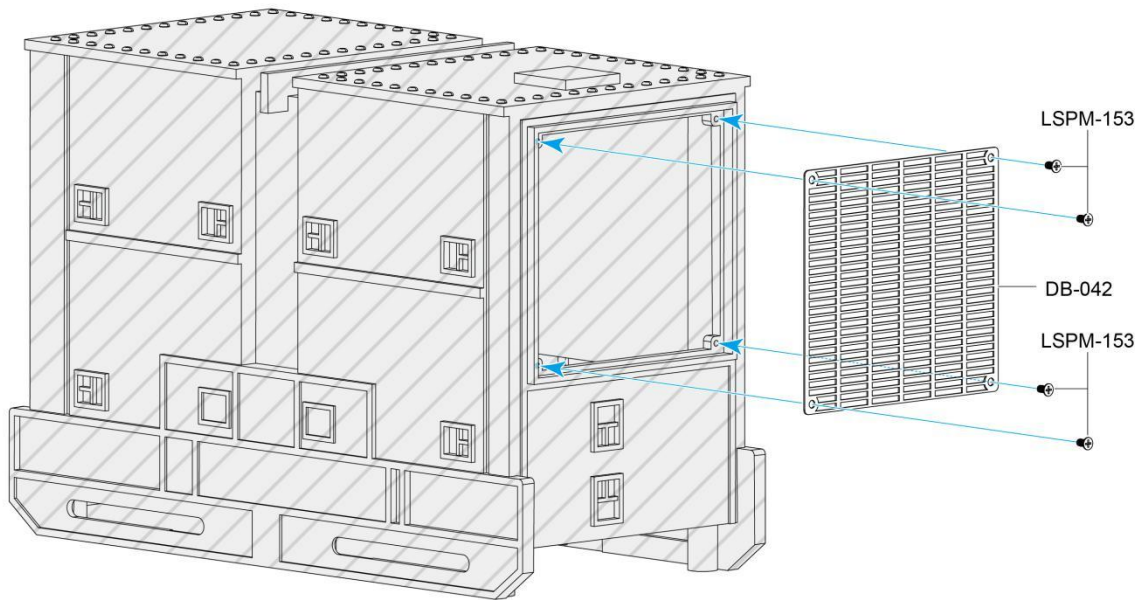

此配件出厂时已组装完成，组装图只是提供组装过程，可用于维护配件。  
This accessory was assembled at the factory, and the assembly diagram simply provides the assembly process, can be used to maintain accessories.

④ ..... 4  
LSTB38 TB Ø3x8MM

**106**

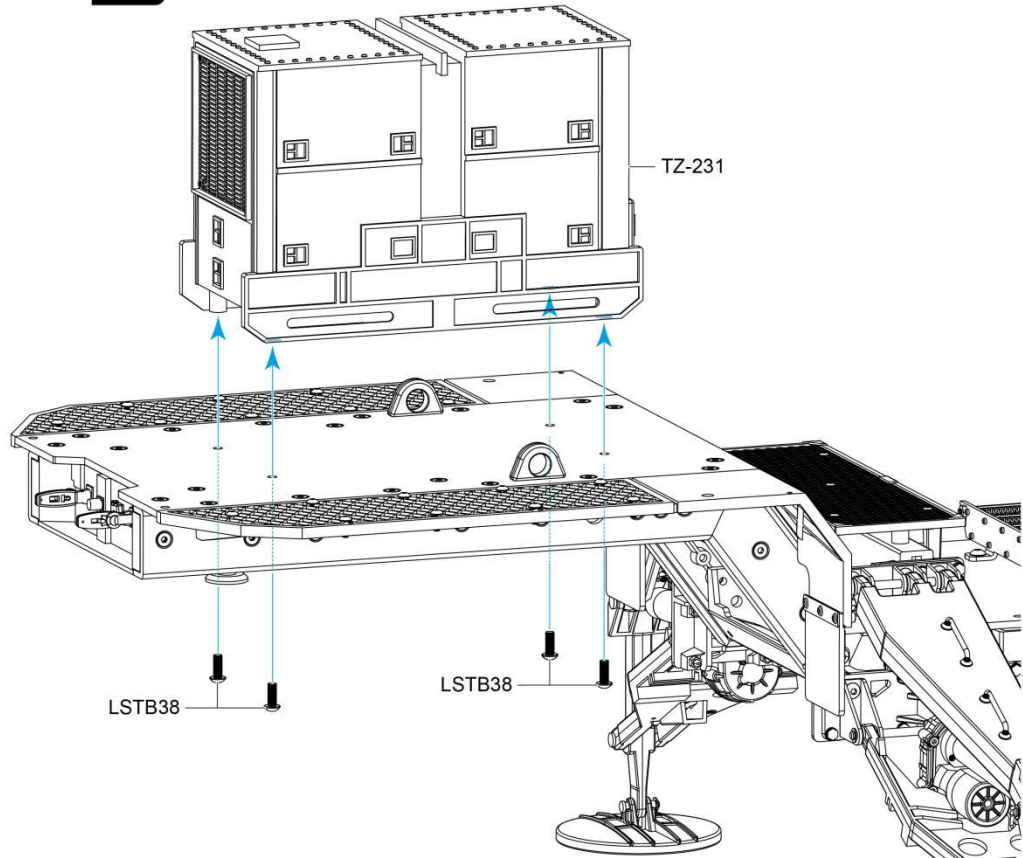

⑥ ..... 6  
LSTB-26 TB Ø2x6MM

④ ..... 4  
TB-097 12MM

**107**



此配件出厂时已组装完成，组装图只是提供组装过程，可用于维护配件。  
This accessory was assembled at the factory, and the assembly diagram simply provides the assembly process, can be used to maintain accessories.

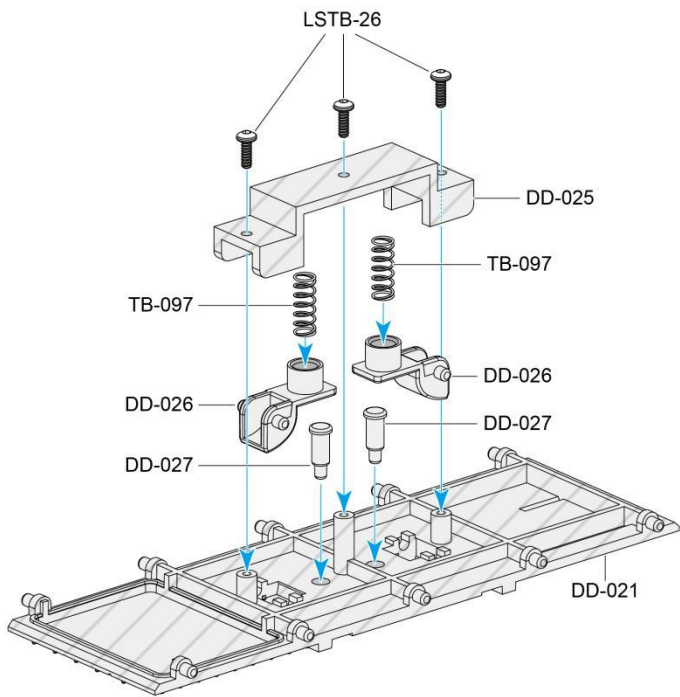
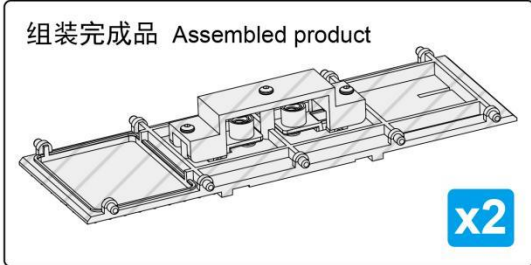



4  
LSTB38 TB Ø3x8MM

### 108

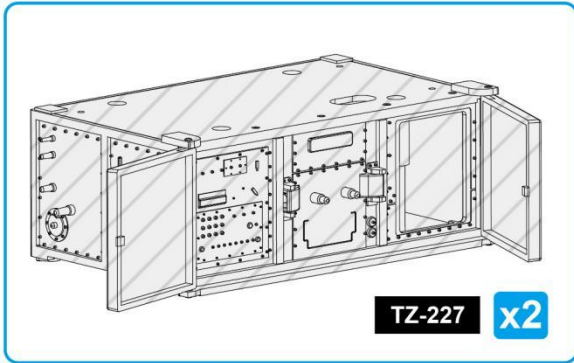

此配件出厂时已组装完成，组装图只是提供组装过程，可用于维护配件。  
This accessory was assembled at the factory, and the assembly diagram simply provides the assembly process, can be used to maintain accessories.

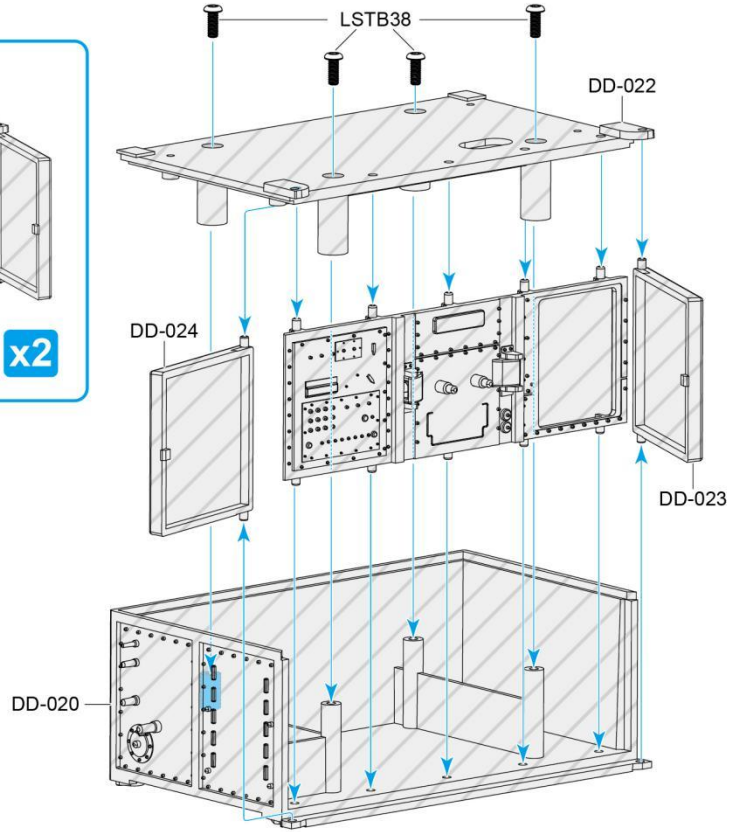

8  
LSKB-38 KB Ø3x8MM

### 109

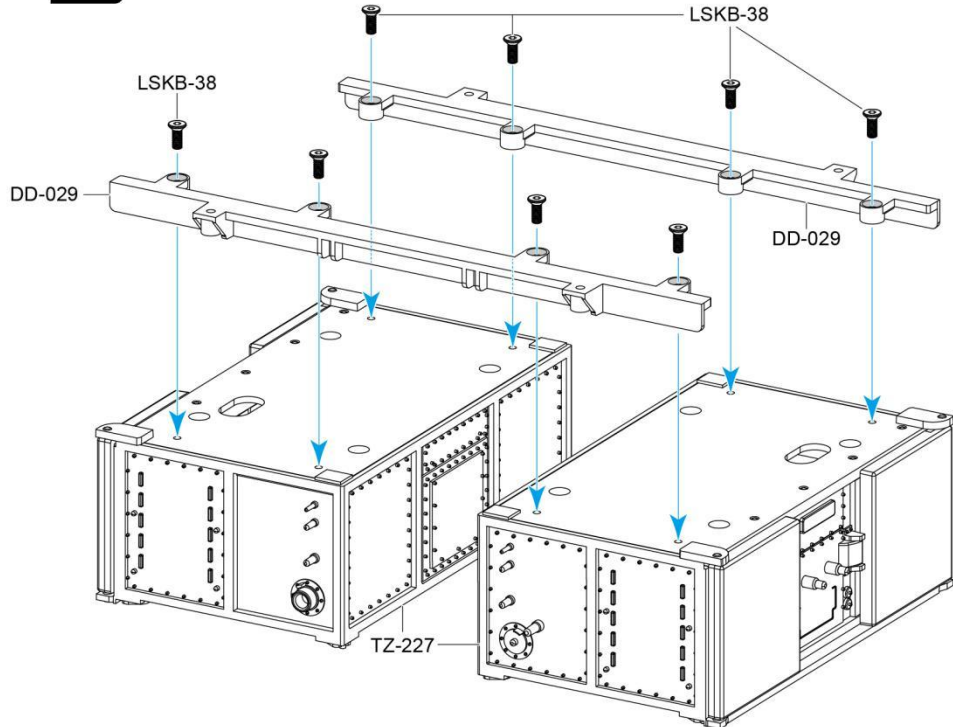

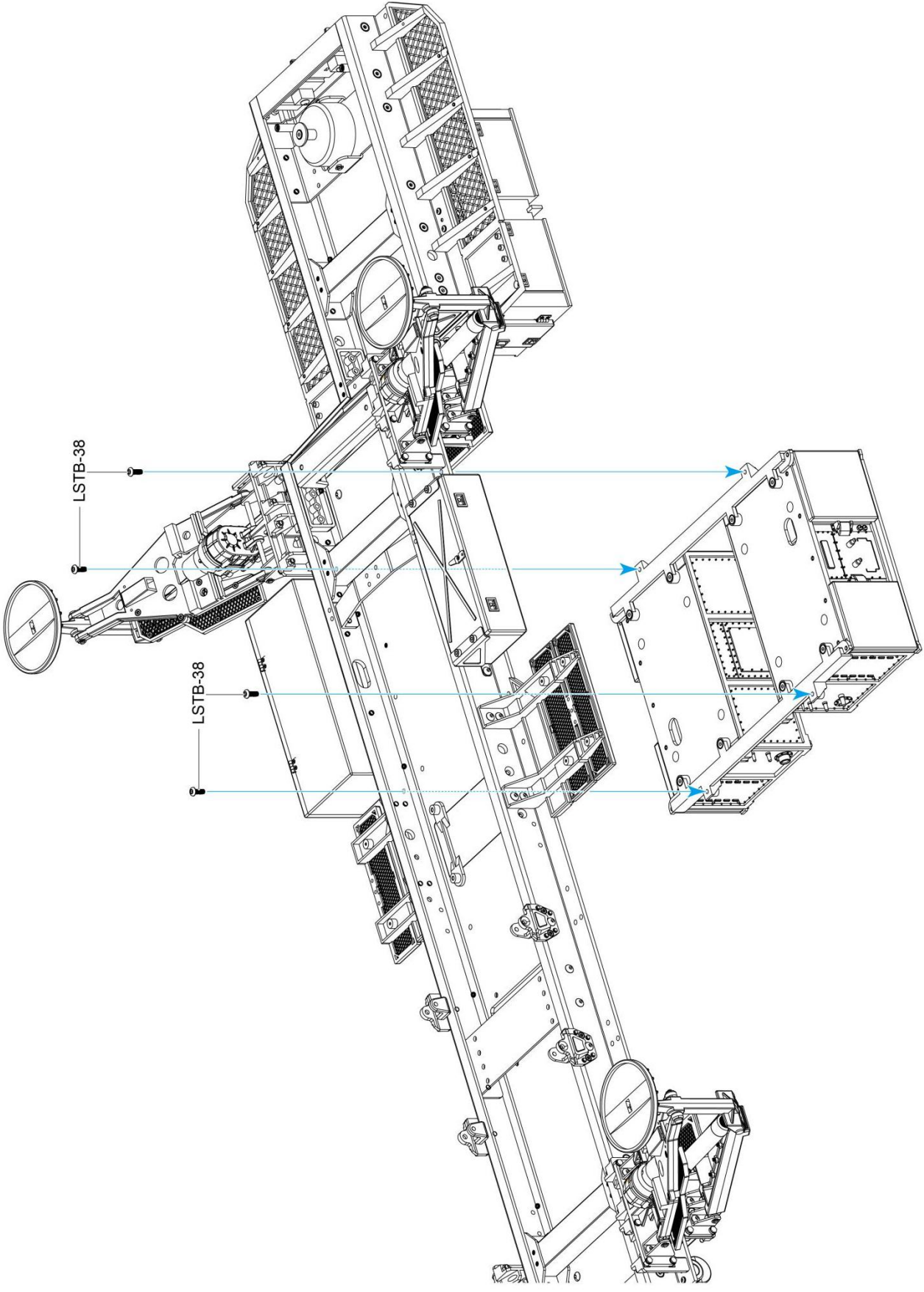

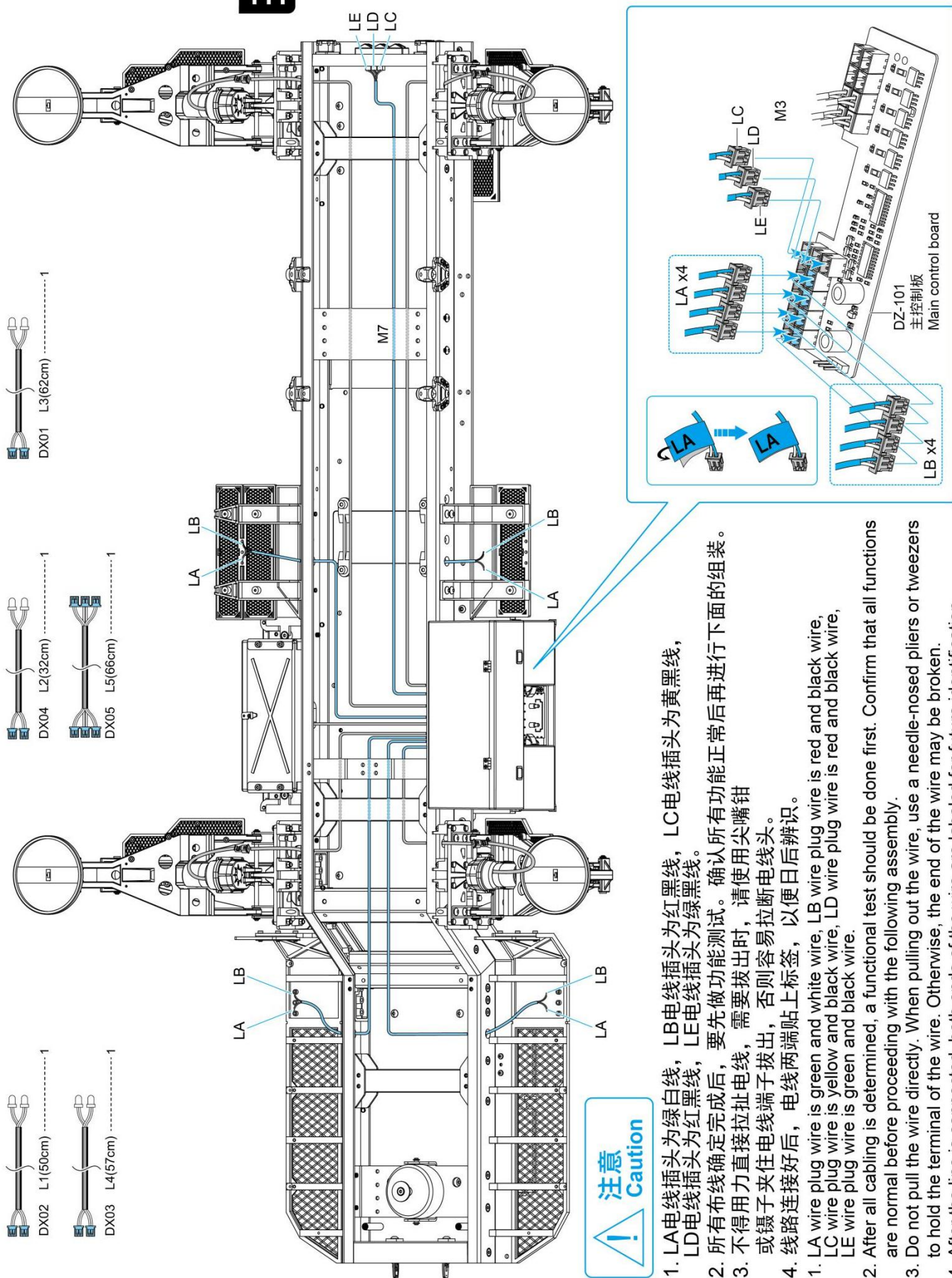





**注意**  
Caution

1. LA电线插头为绿白线，LB电线插头为红黑线，LE电线插头为红黑线，LD电线插头为红黑线，LC电线插头为黄黑线。
2. 所有布线确定完成后，要先做功能测试。确认所有功能正常后再进行下面的组装。
3. 不得用力直接拉扯电线，需要拔出时，请使用尖嘴钳或镊子夹住电线端子拔出，否则容易拉断电线头。
4. 线路连接好后，电线两端贴上标签，以便日后辨识。
  1. LA wire plug wire is green and white wire, LB wire plug wire is red and black wire, LC wire plug wire is yellow and black wire, LD wire plug wire is red and black wire, LE wire plug wire is green and black wire.
2. After all cabling is determined, a functional test should be done first. Confirm that all functions are normal before proceeding with the following assembly.
3. Do not pull the wire directly. When pulling out the wire, use a needle-nosed pliers or tweezers to hold the terminal of the wire. Otherwise, the end of the wire may be broken.
4. After the line is connected, both ends of the wire are labeled for future identification.

-  ..... 8  
LSPB-174 PB Ø1.7X4MM
-  ..... 2  
P544 KB Ø2x6MM
-  ..... 4  
TBC-004 黄色转向灯罩  
Yellow turn lamp shade
-  ..... 4  
TBC-005 红色雾灯罩  
Red fog lampshade

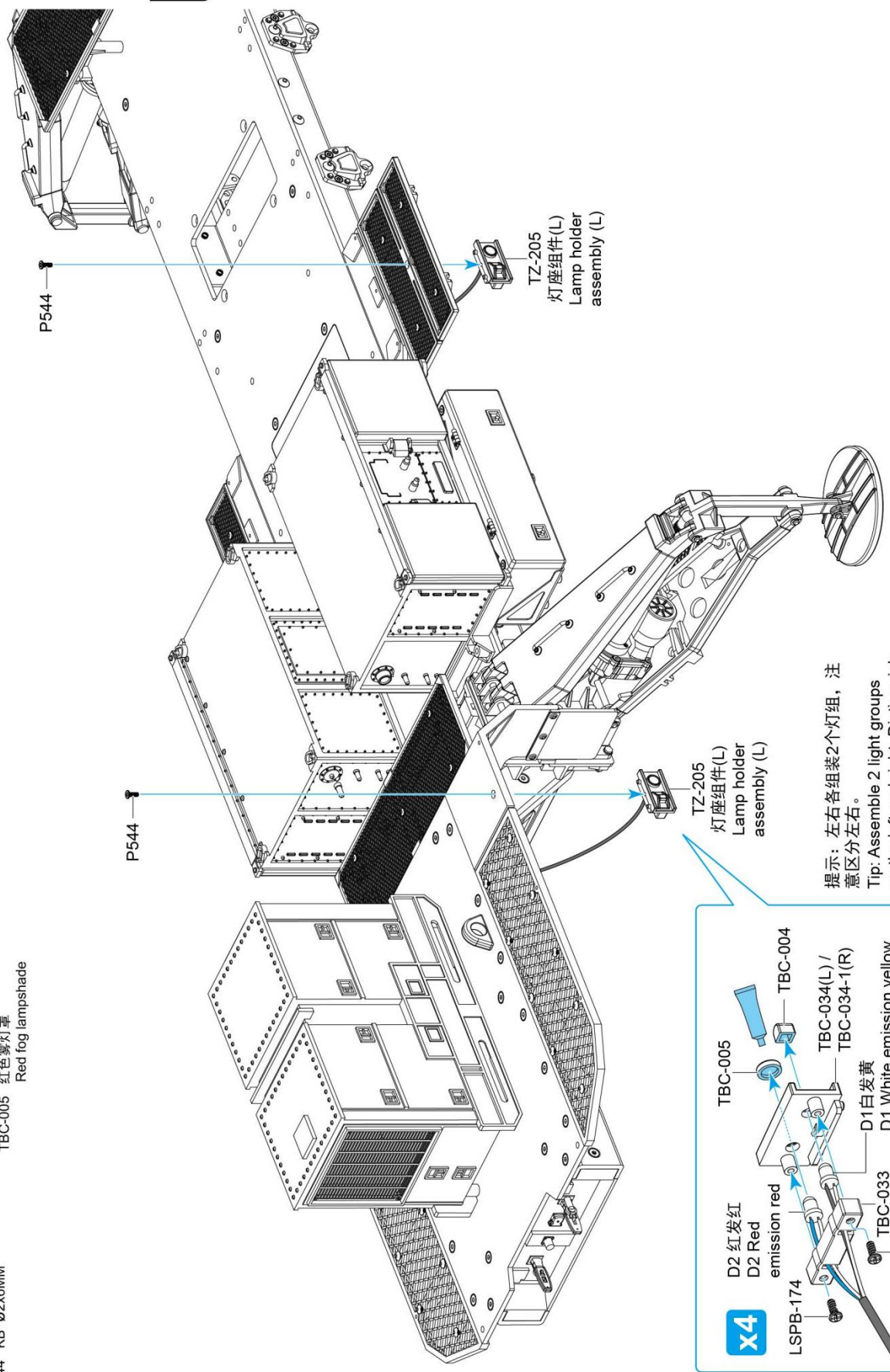

**X4**

- TBC-005
- TBC-004
- TBC-034(L) / TBC-034-1(R)
- D1 白发黄  
D1 White emission yellow
- TBC-033
- LSPB-174
- D2 红发红  
D2 Red emission red

TZ-205  
灯座组件(L)  
Lamp holder  
assembly (L)

TZ-205  
灯座组件(L)  
Lamp holder  
assembly (L)

提示：左右各组装2个灯组，注意区分左右。  
Tip: Assemble 2 light groups on the left and right. Distinguish between left and right.

④ P544 KB Ø2x6MM

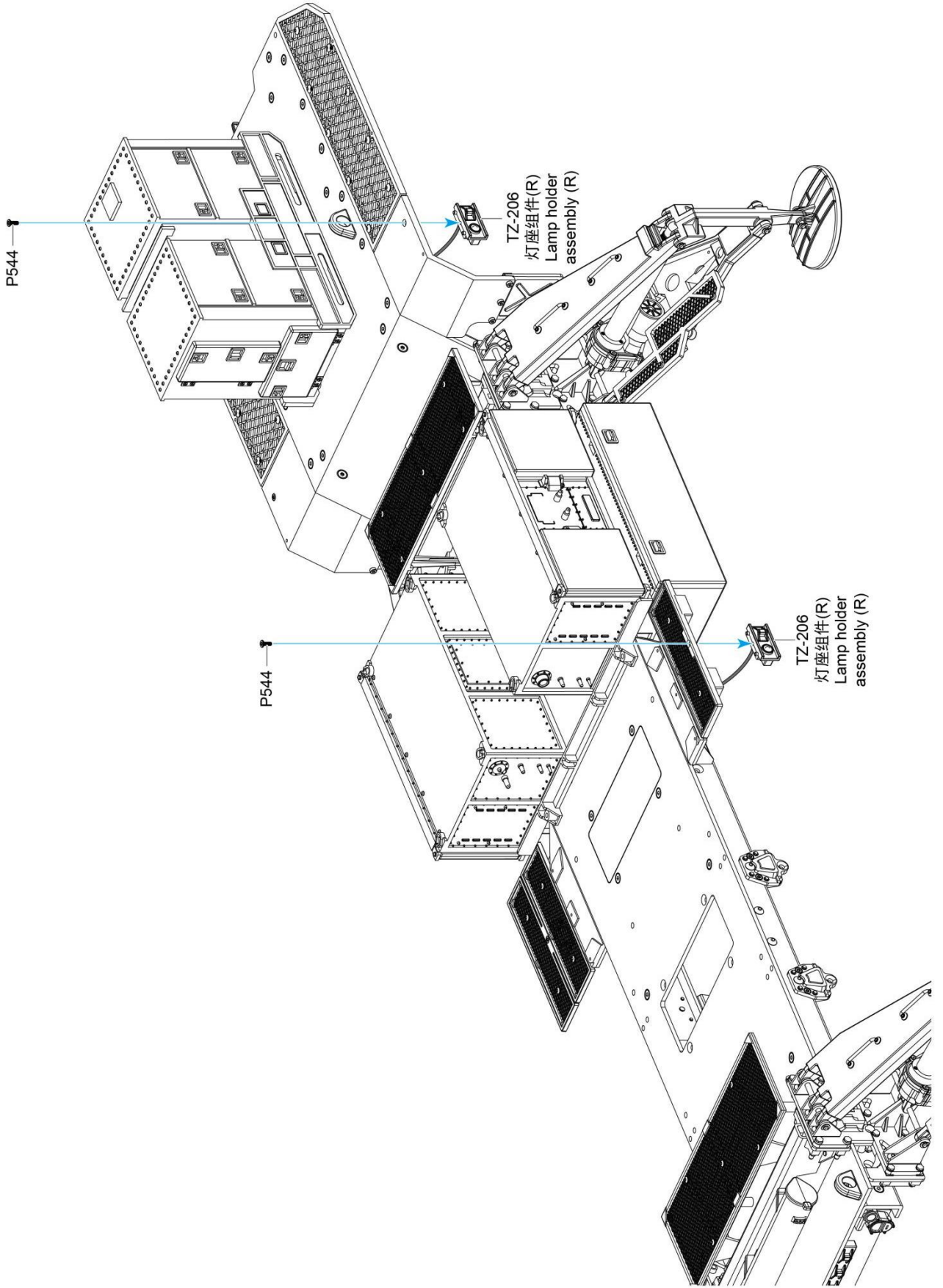

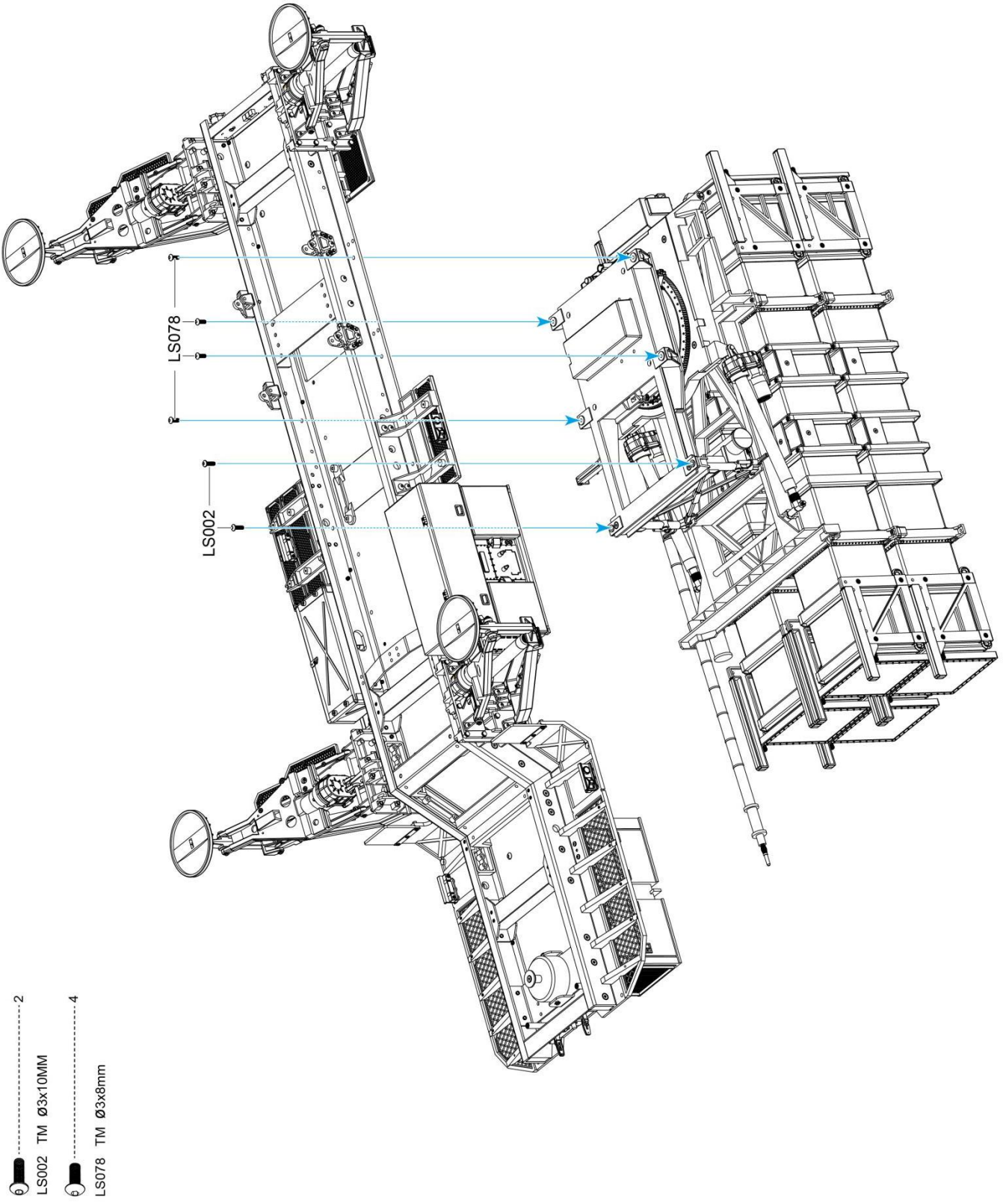

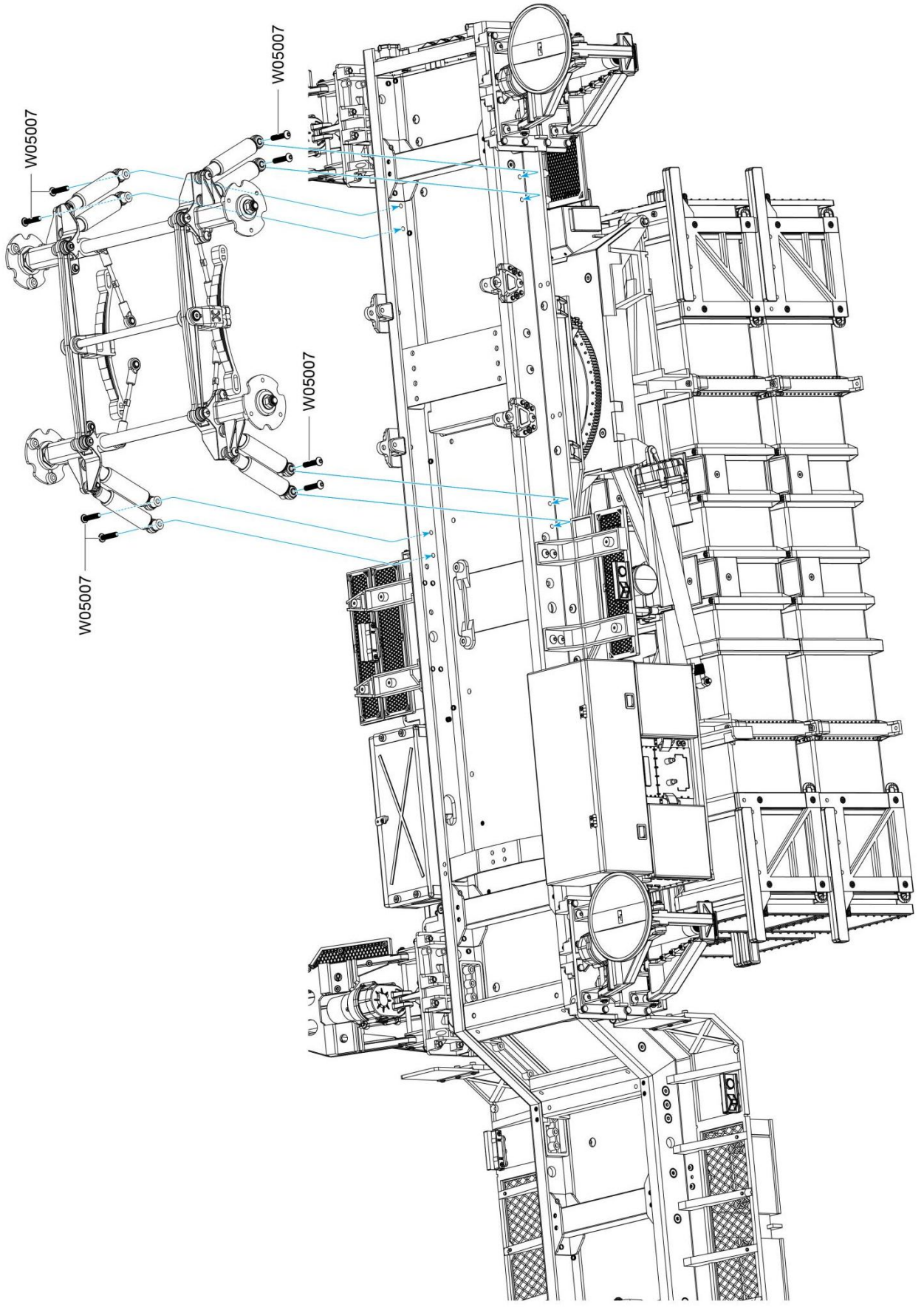

W05007 TM Ø3x14MM

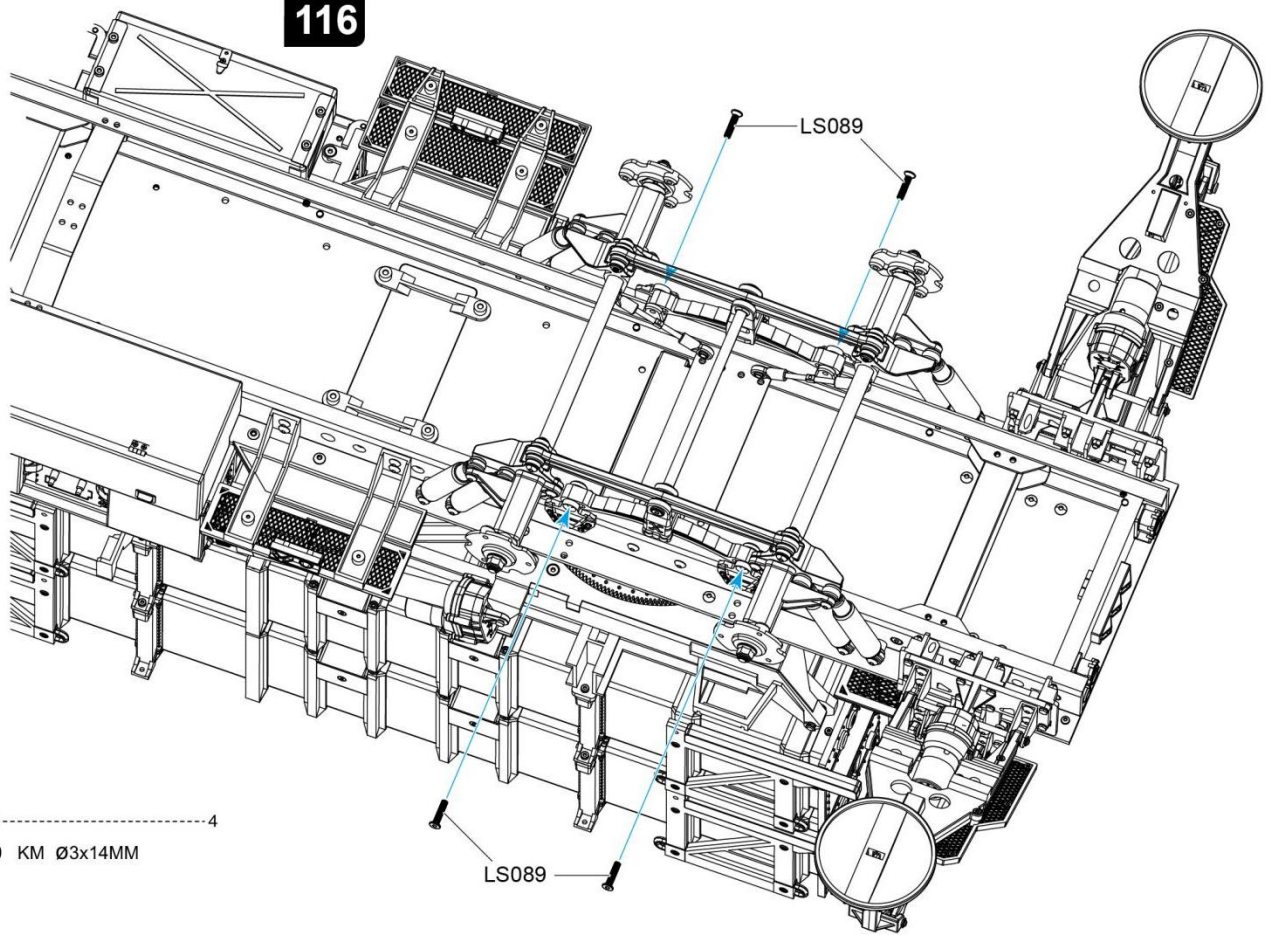

**116**



 ..... 4  
 LS089 KM Ø3x14MM

 ..... 6  
 W05009 HM Ø2x6MM

 ..... 2  
 C044

**117**

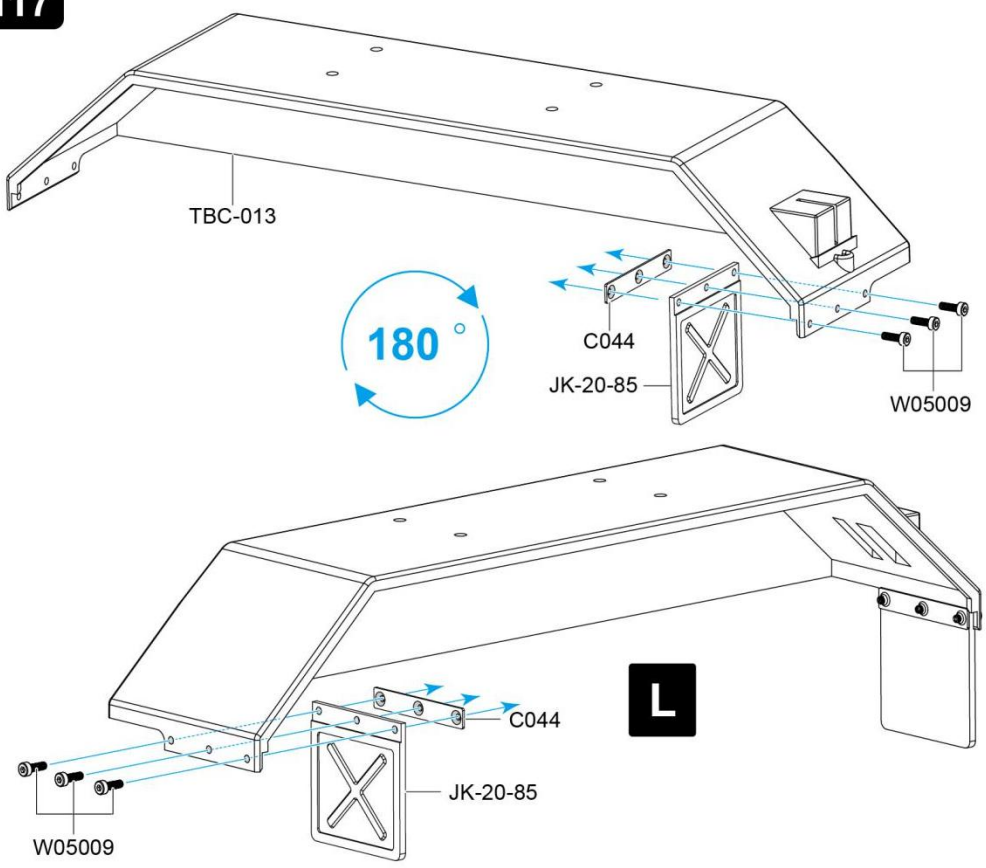

TBC-013

180°

C044

JK-20-85

W05009

**L**

C044

JK-20-85

W05009



LSKB-38 KB Ø3x8MM

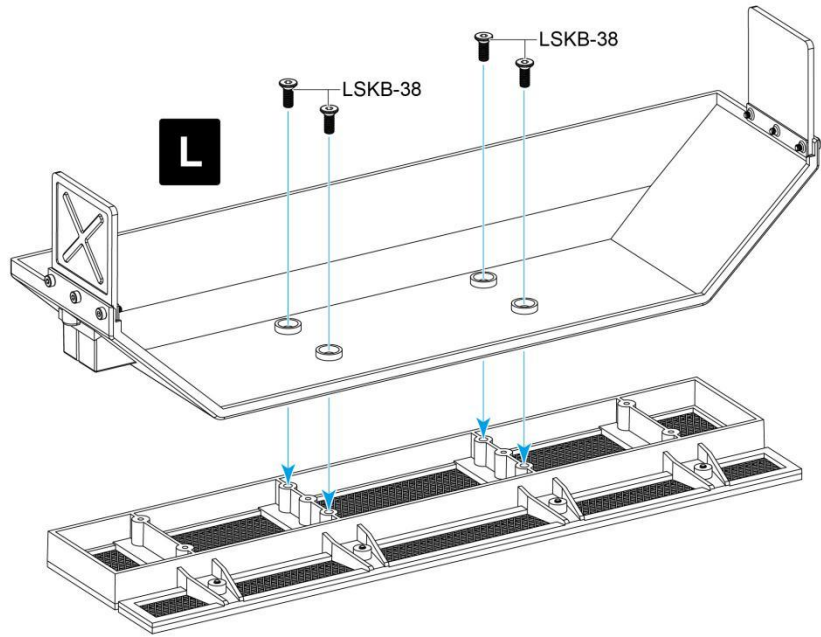

118

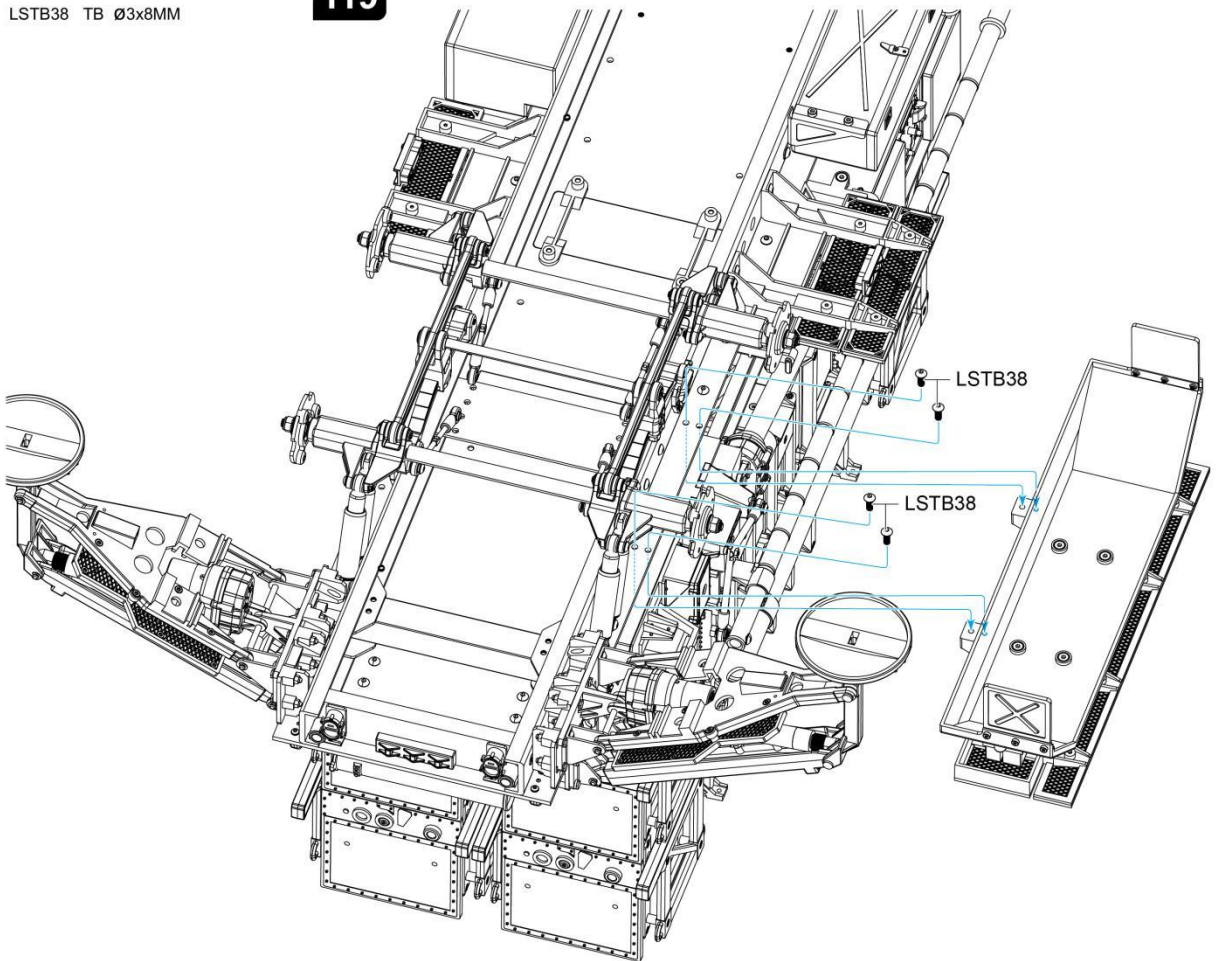

LSTB38 TB Ø3x8MM

119



-  ..... 6  
W05009 HM Ø2x6MM
-  ..... 2  
C044

**120**

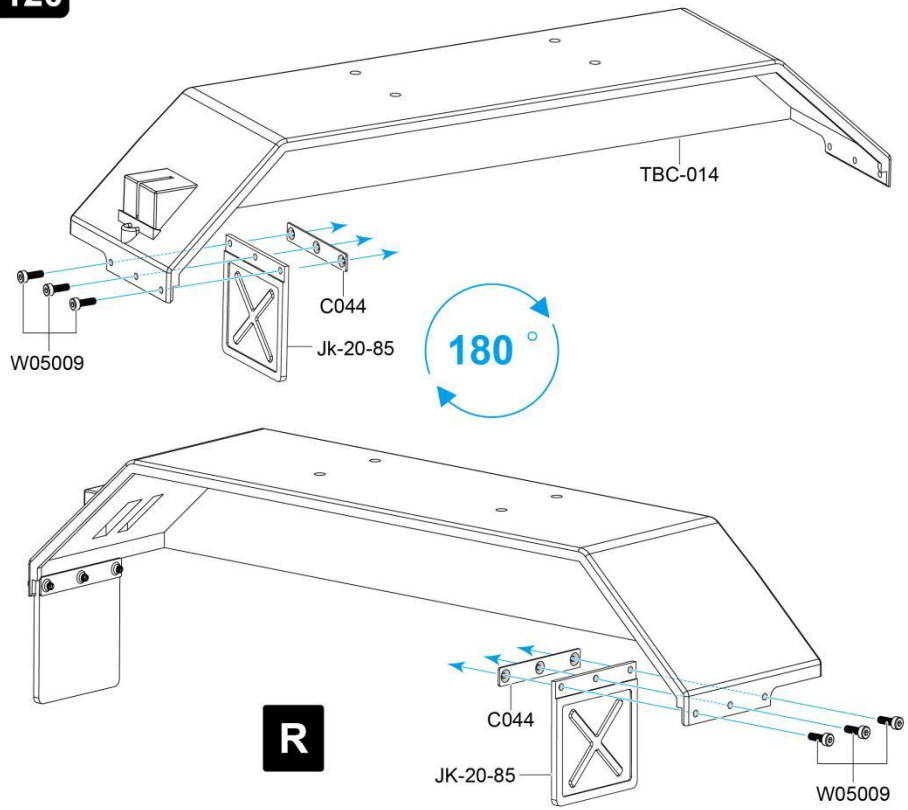

-  ..... 4  
LSKB-38 KB Ø3x8MM

**121**

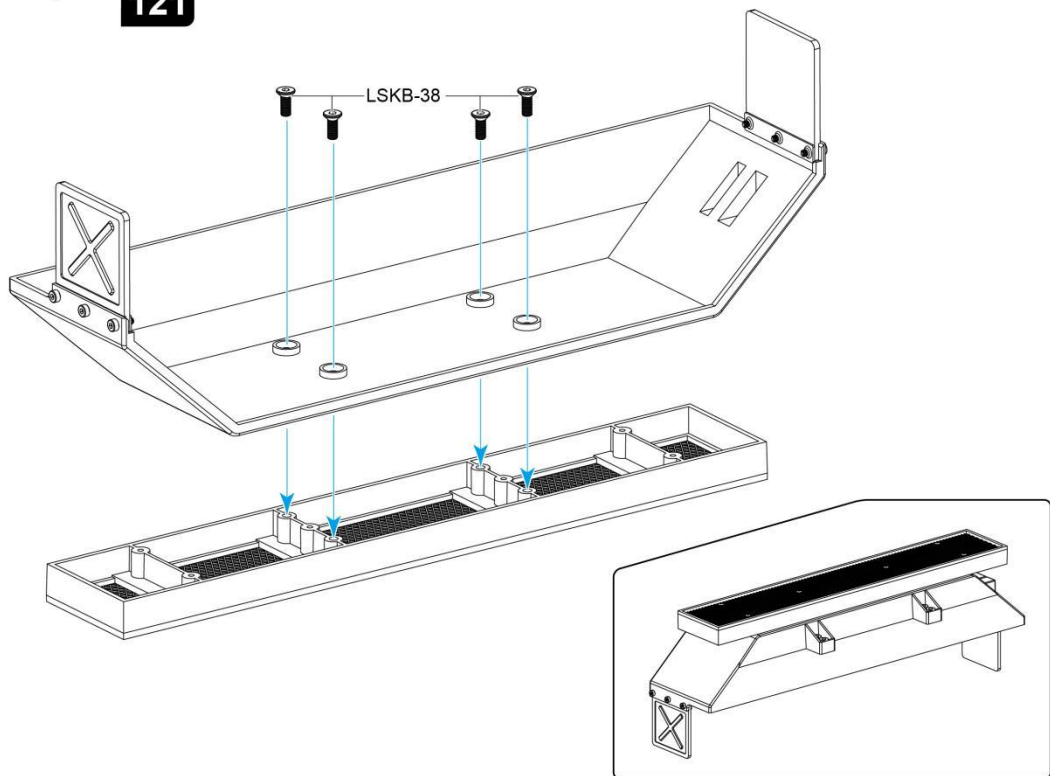

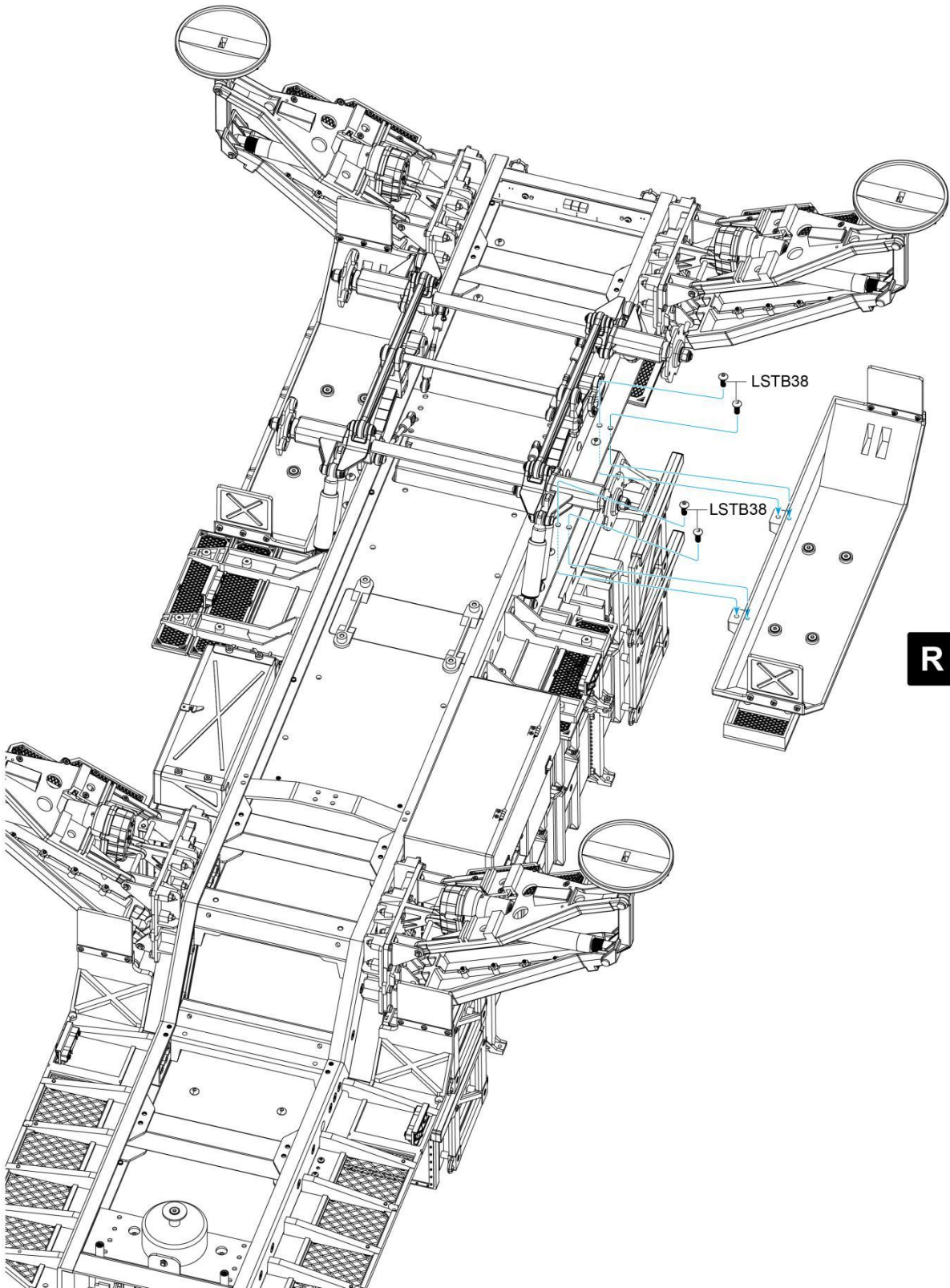

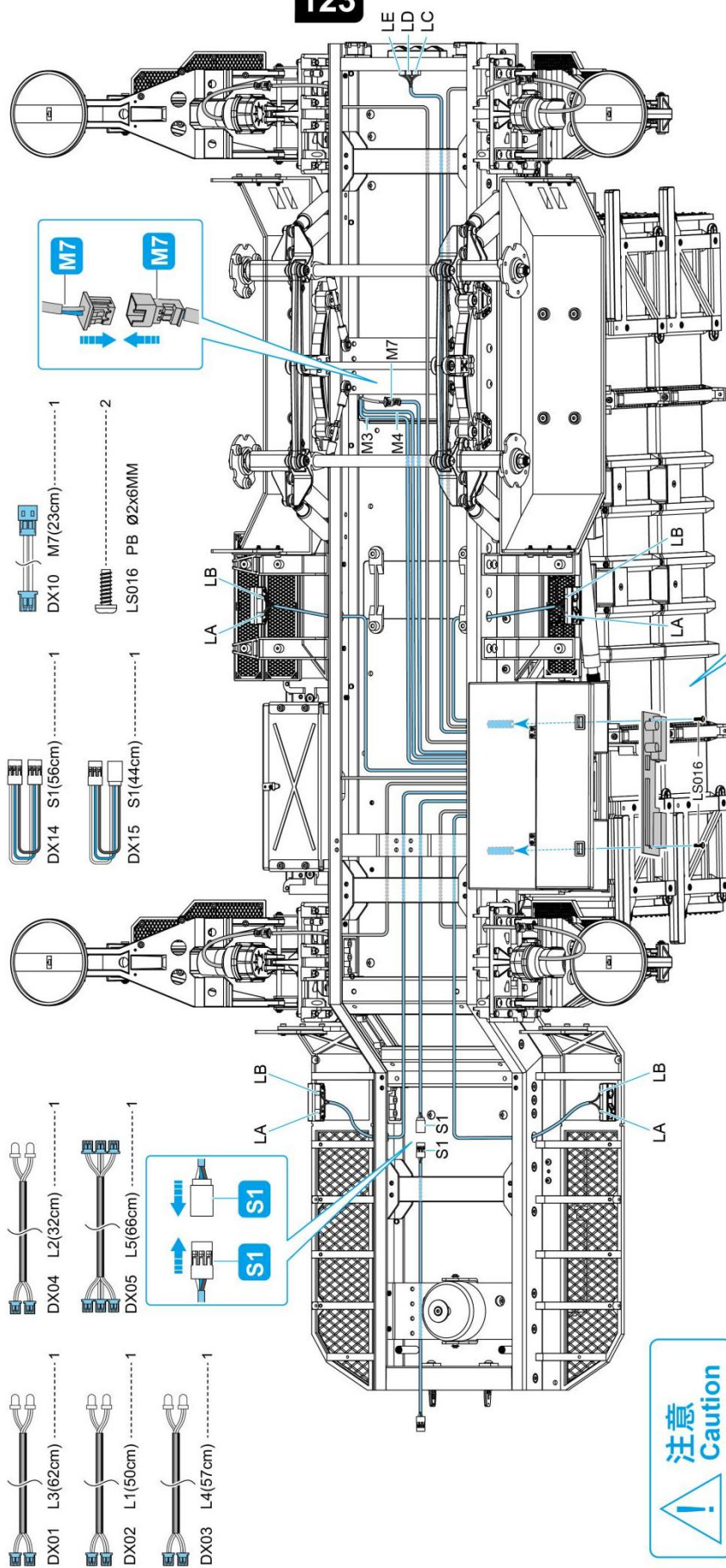

- DX01 L3(62cm) .....1
- DX02 L1(50cm) .....1
- DX03 L4(57cm) .....1
- DX04 L2(32cm) .....1
- DX05 L5(66cm) .....1
- DX14 S1(56cm) .....1
- DX15 S1(44cm) .....1

- M7 (2x) .....1
- M3 .....1
- M4 .....1
- S1 (2x) .....1
- LS016 PB Ø2x6MM .....2

**注意**  
Caution

1. S1为功能控制线(延长线), 用于连接前车头使用, 仅限使用本厂8通方控操作时连接, 可先将连接线布置到位, 以方便切换操作模式;
2. 注意正负电源不得接反, 按照红正黑负对接, 同时注意电路板插针的正负极, 确认后连接正电源再做功能测试, 无误后方可进行余下组装。
3. 连接电线时, 请注意电线的合理穿插, 不得用力直接拉扯电线, 需要拔出时, 请使用尖嘴钳或镊子夹住电线端子拔出, 否则容易拉断电线头。
4. 功能确认无误后将所有电线捋顺并用扎带捆绑整齐。视情况根据需要进行合理捆绑电线。
5. 线路连接好后, 电线两端贴上标签, 以便日后辨识。

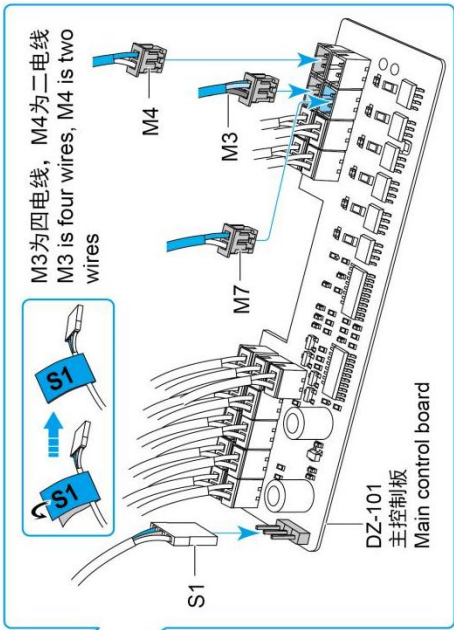

1. S1 is a functional control line (extension line), used to connect to the front car head, and can only be connected when using the factory's 8-way square control operation. The connection line can be arranged in place to facilitate switching operation modes.
2. Note that the positive and negative power supply must not be connected reversely. Connect them in accordance with the red positive and black negative. At the same time, pay attention to the positive and negative poles of the circuit board pins. After confirming the connection is correct, perform the function test, and then proceed to the rest of the assembly.
3. When connecting the wires, please pay attention to the reasonable insertion of the wires. Do not pull the wires directly. When you need to pull them out, please use needle-nose pliers or tweezers to clamp the wire terminals and pull them out, otherwise the wire ends will be easily pulled off.
4. After the function is confirmed to be correct, straighten all the wires and tie them neatly with cable ties. Bundle the wires reasonably according to the situation and needs.
5. After the wiring is connected, label both ends of the wire for easy identification in the future.

组装此步骤时，先确认该产品功能是否全部正常！  
When assembling this step, first confirm whether the  
product functions are all normal!

**特别提示**  
Special note

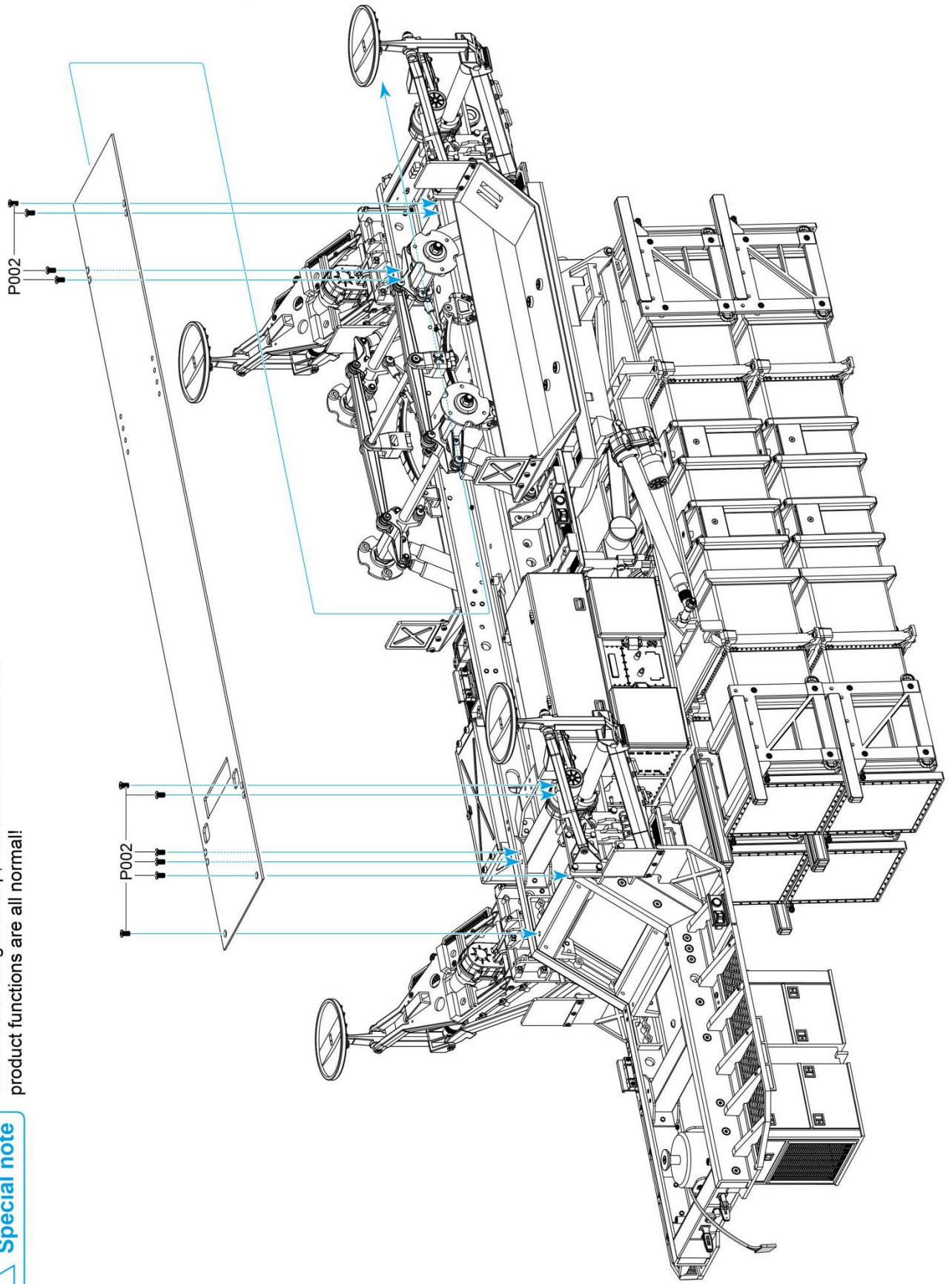

④ ..... 8  
P002 KM Ø3x6MM

125

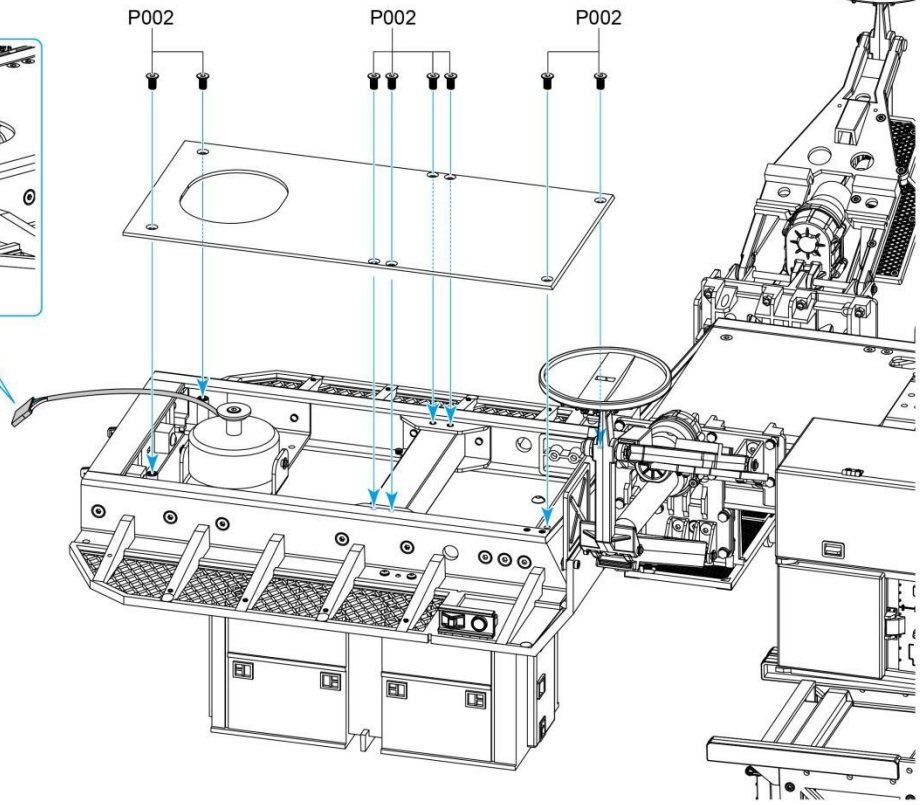
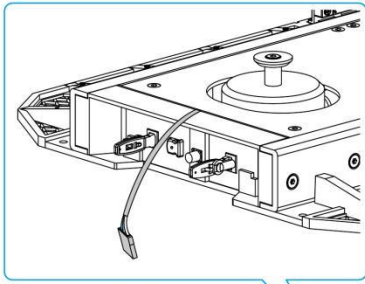

④ ..... 4  
P002 KM Ø3x6MM

126

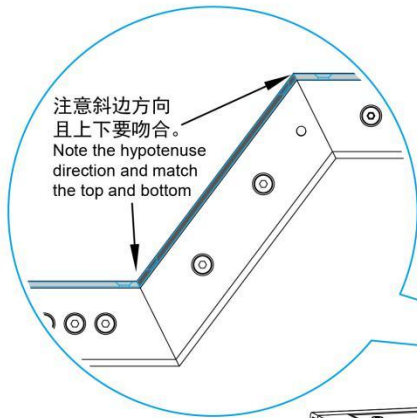

由于零件尺寸公差，此处组装会出现误差属于正常现象，可适当自行调整。  
Due to the size tolerance of parts, it is normal for assembly errors to occur here, which can be adjusted appropriately

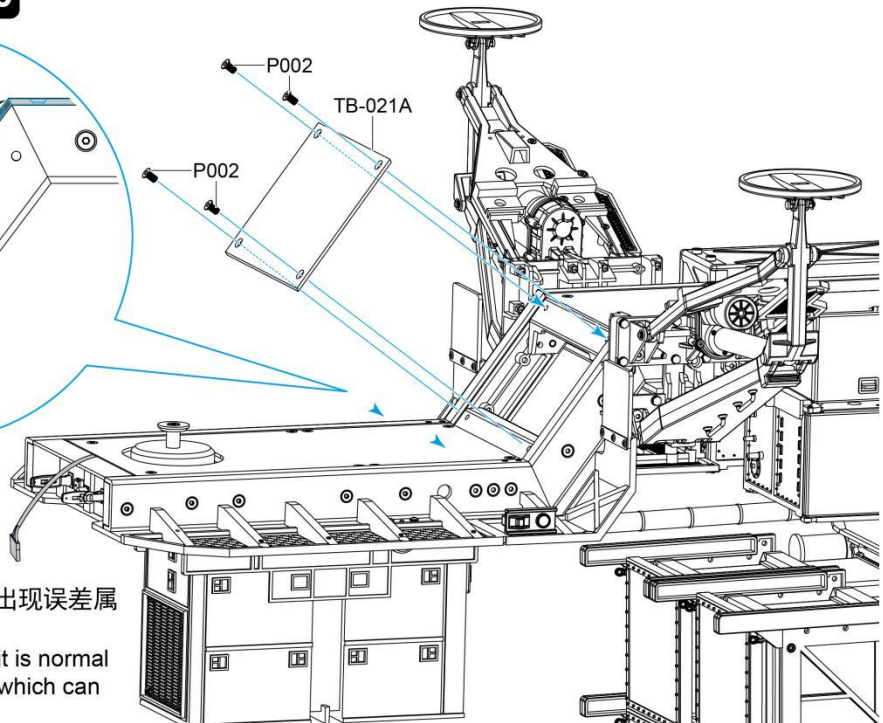

LS001 TM Ø3x6MM 8

TB-087 4

127

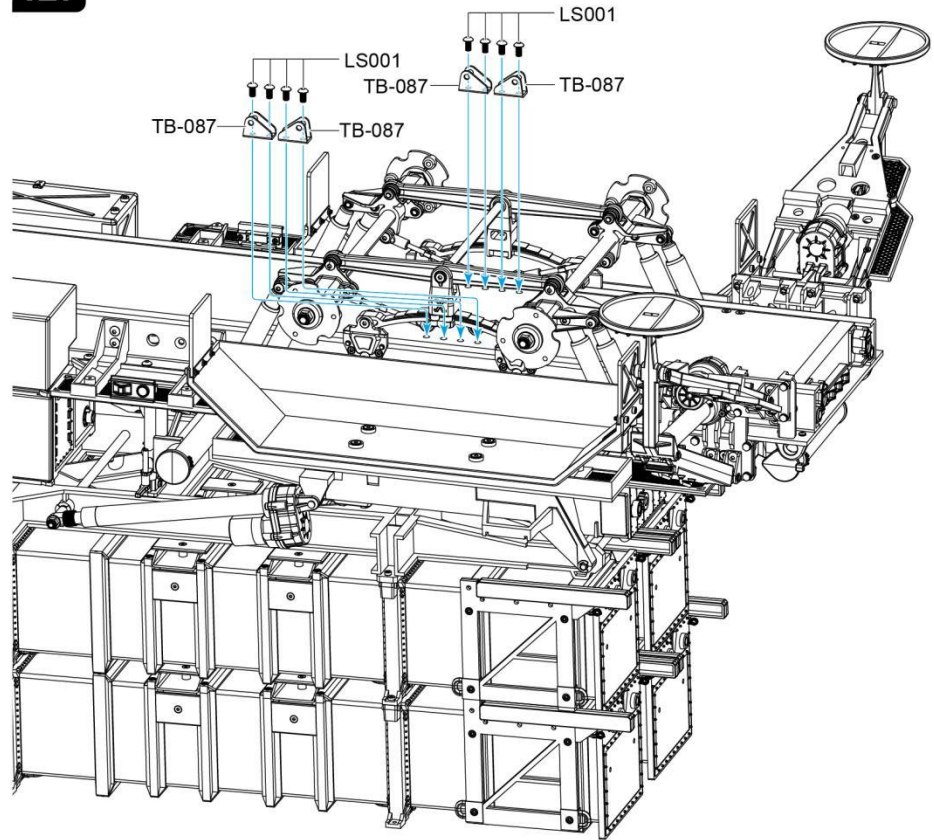



W05019 TM Ø3x12MM 4

LS019 M3 4

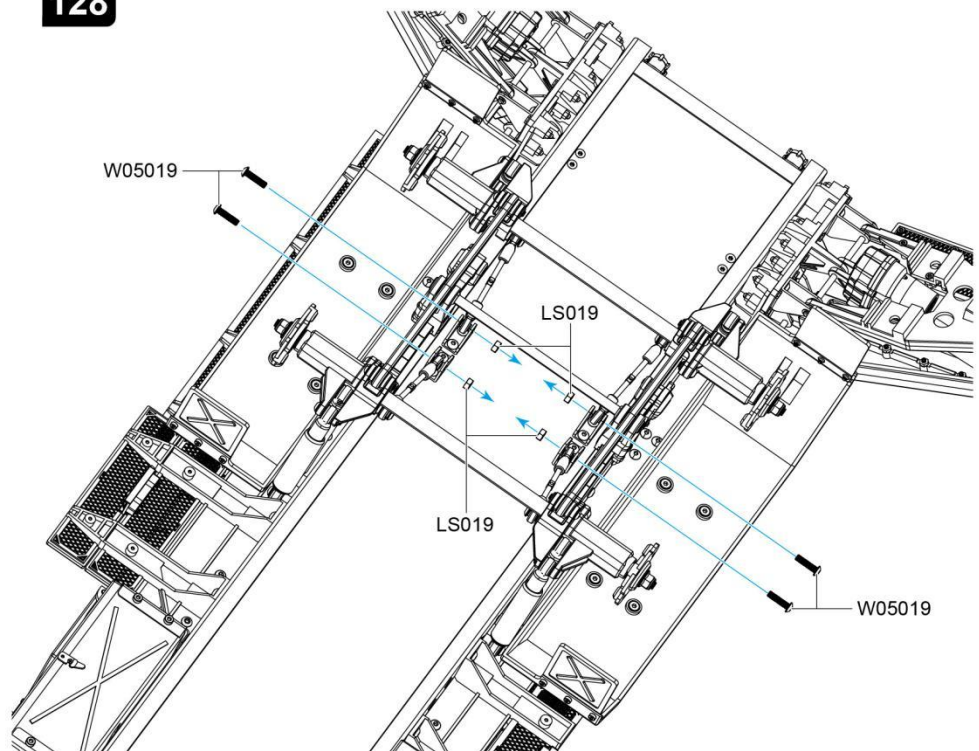



128

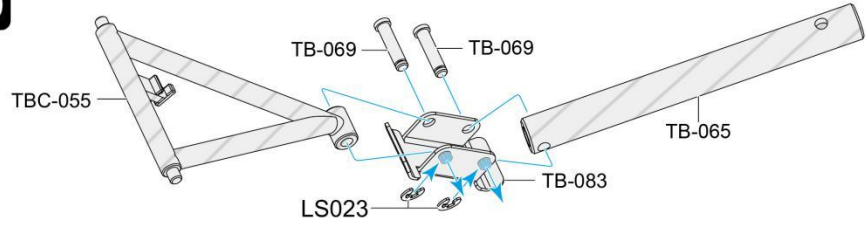

-  ..... 2  
TB-069 Ø3x14mm
-  ..... 2  
LS023 Ø2mm



### 129

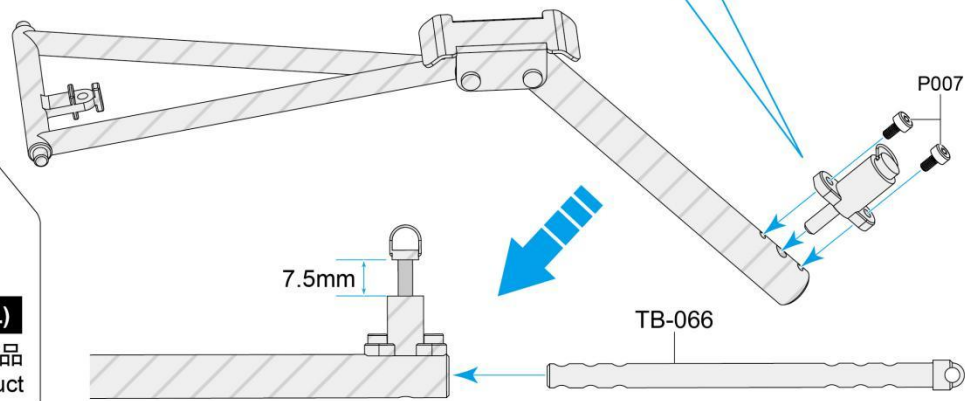
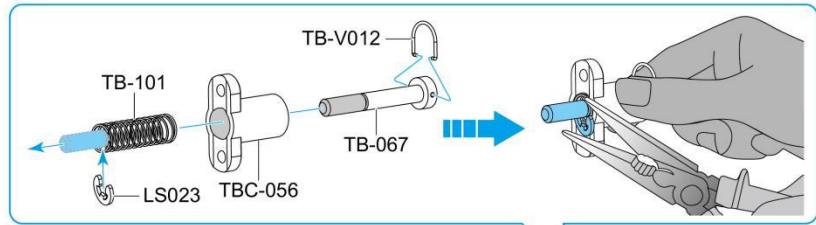

-  ..... 2  
P007 HM Ø2x4MM
-  ..... 1  
LS023 Ø2mm
-  ..... 1  
TB-101
-  ..... 1  
TB-V012

### 130



-  ..... 8  
LSZ0701 TM Ø3x5MM
-  ..... 2  
TB-084
-  ..... 2  
TB-085

### 131

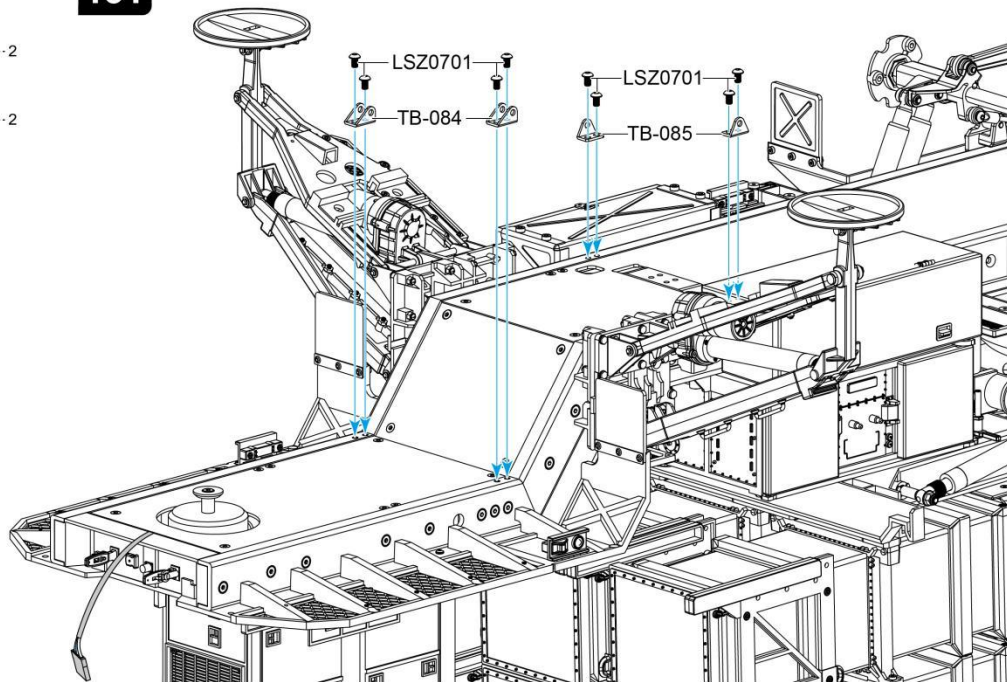





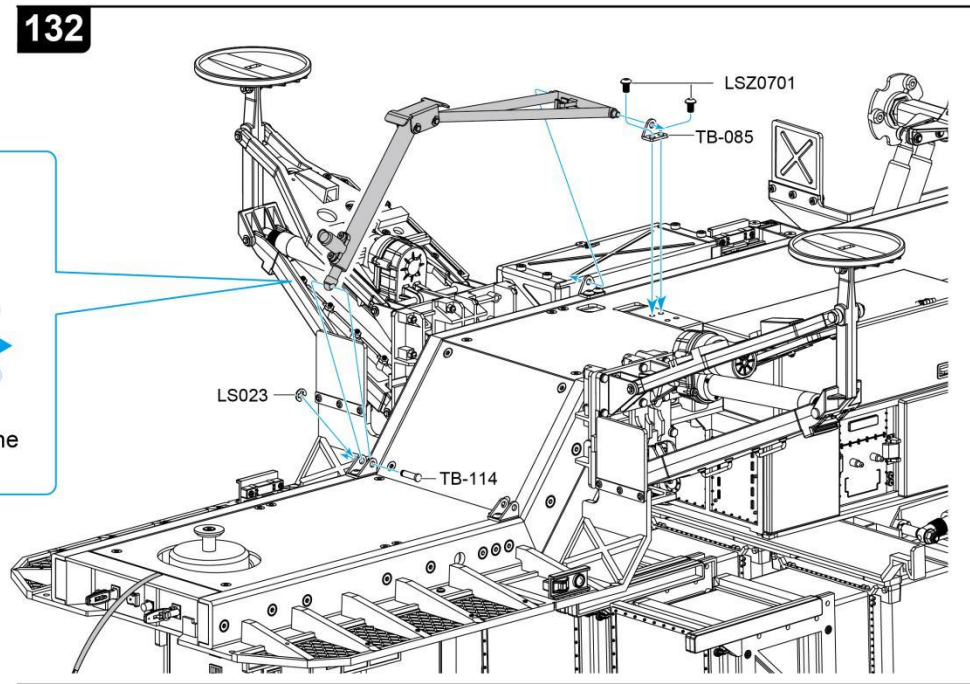
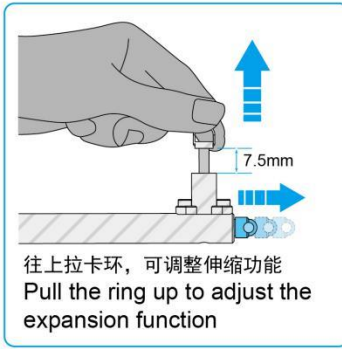

-  ..... 2  
LSZ0701 TM Ø3x5MM
-  ..... 1  
TB-114 Ø3x12MM

### 132





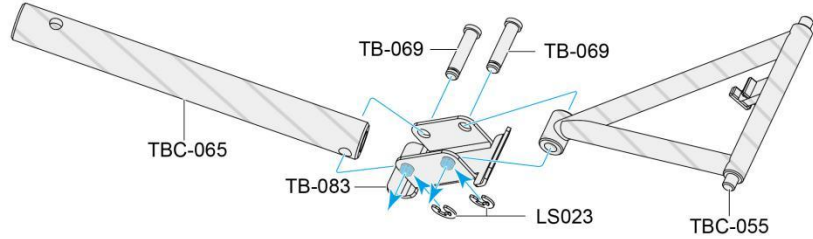

-  ..... 1  
LS203 Ø2mm
-  ..... 1  
TB-085
-  ..... 2  
TB-069 Ø3x14mm
-  ..... 2  
LS203 Ø2mm

### 133

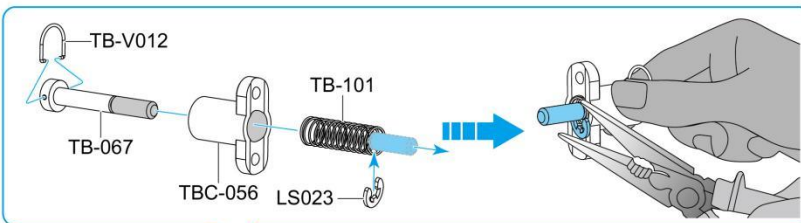

### 134



-  ..... 2  
P007 HM Ø2x4MM
-  ..... 1  
LS203 Ø2mm
-  ..... 1  
TB-101
-  ..... 1  
TB-V012

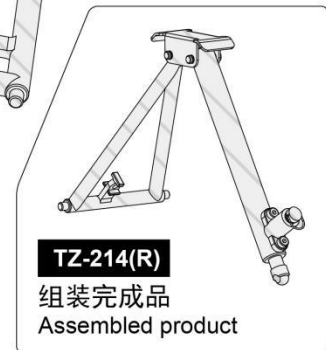
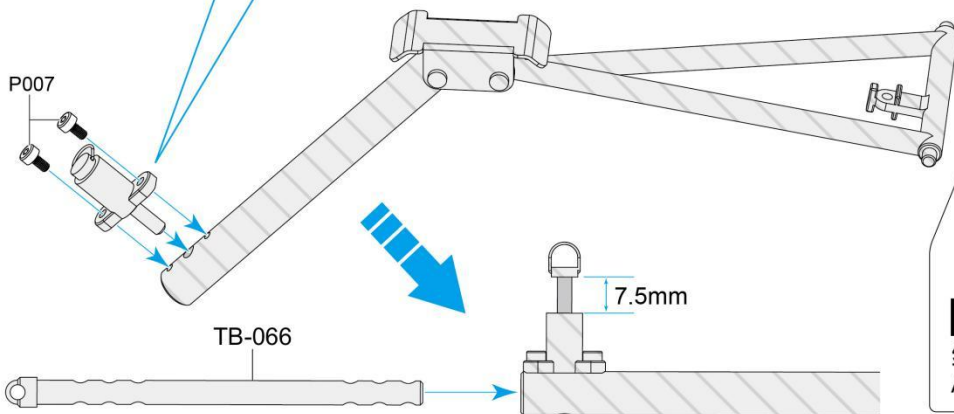

-  .....2  
LSZ0701 TM Ø3x5MM
-  .....1  
TB-114 Ø3x12MM
-  .....1  
LS023 Ø2mm
-  .....1  
TB-085

### 135

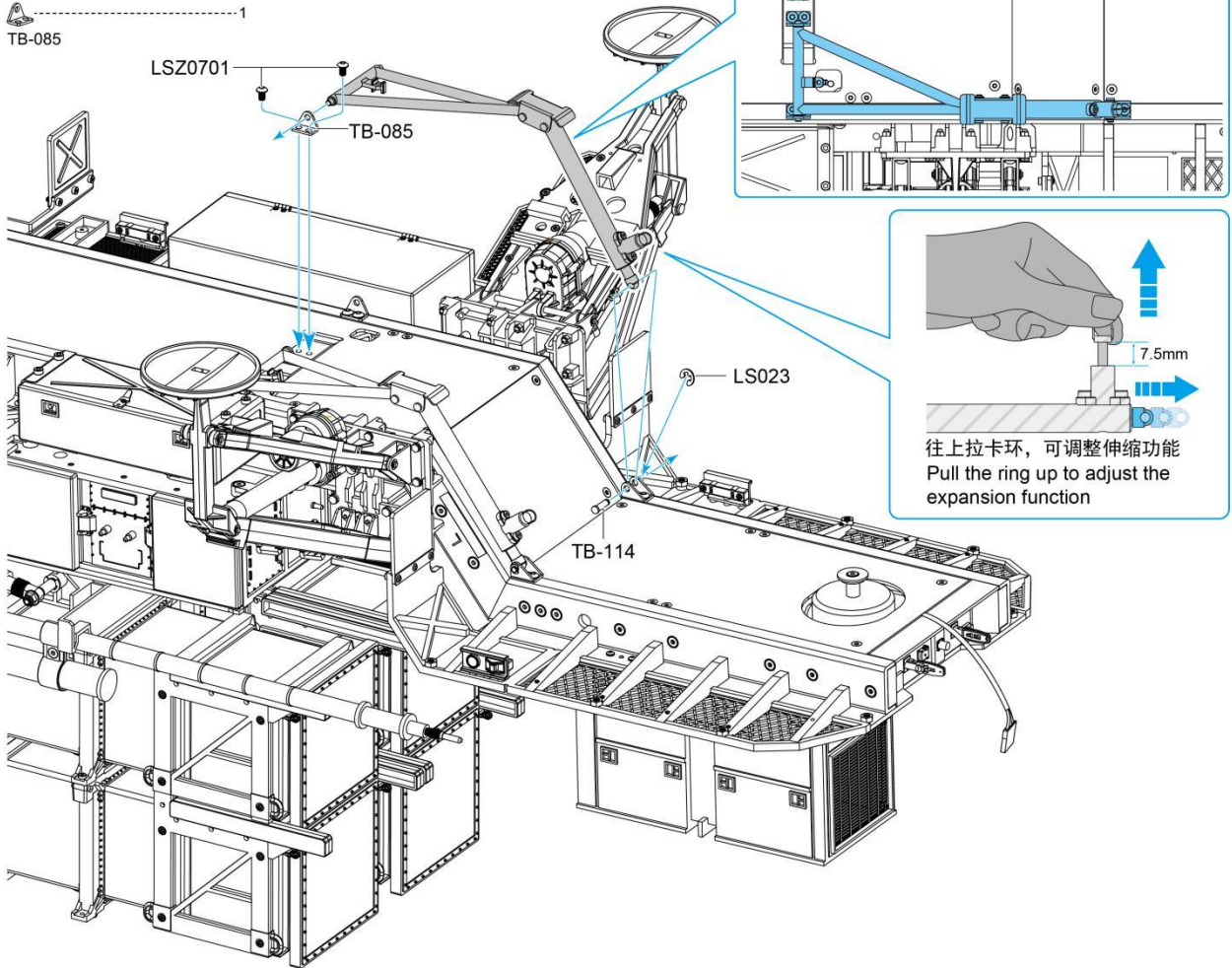

-  .....20  
P5612 HB Ø2.6x8MM

### 136

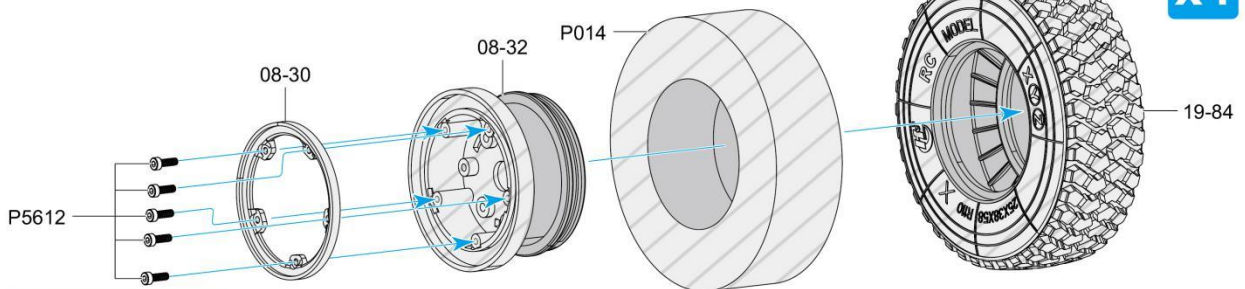

此配件出厂时已组装完成，组装图只是提供组装过程，可用于维护配件。  
This accessory was assembled at the factory, and the assembly diagram simply provides the assembly process, can be used to maintain accessories.

LS078 TM Ø3x8mm 6

137

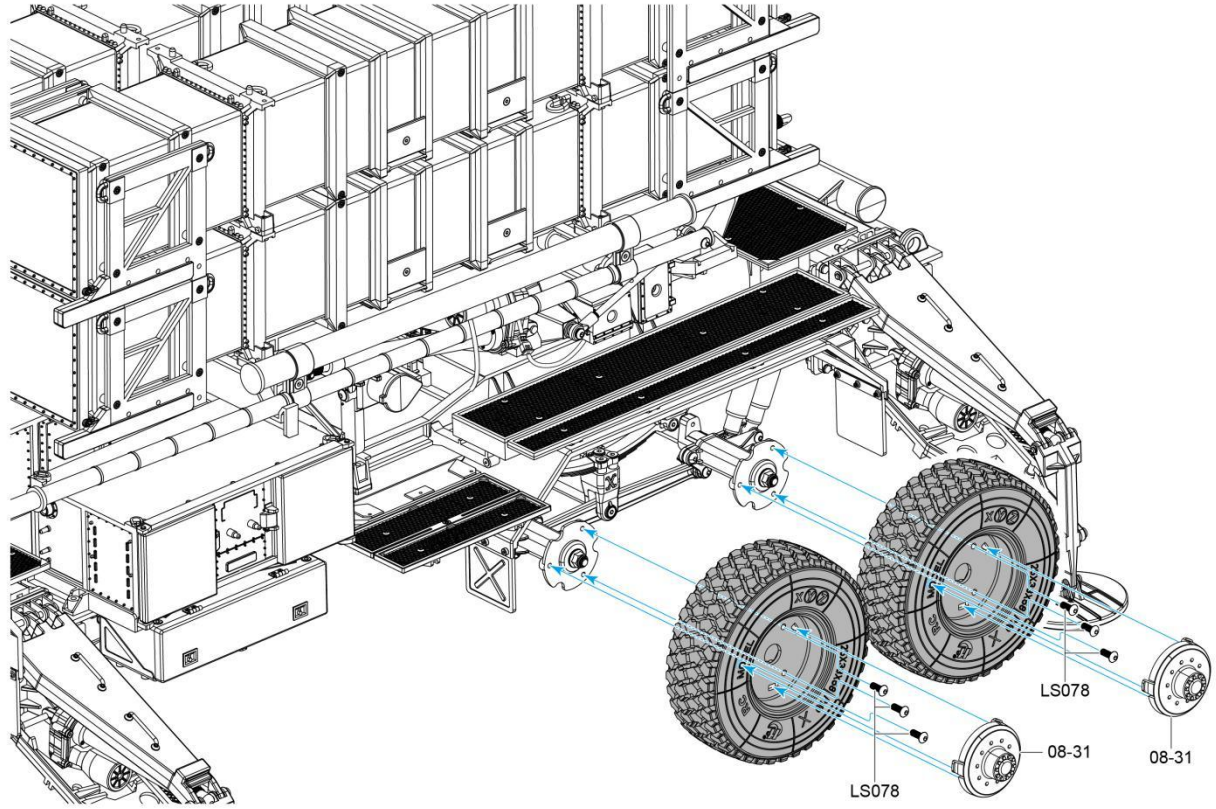

138

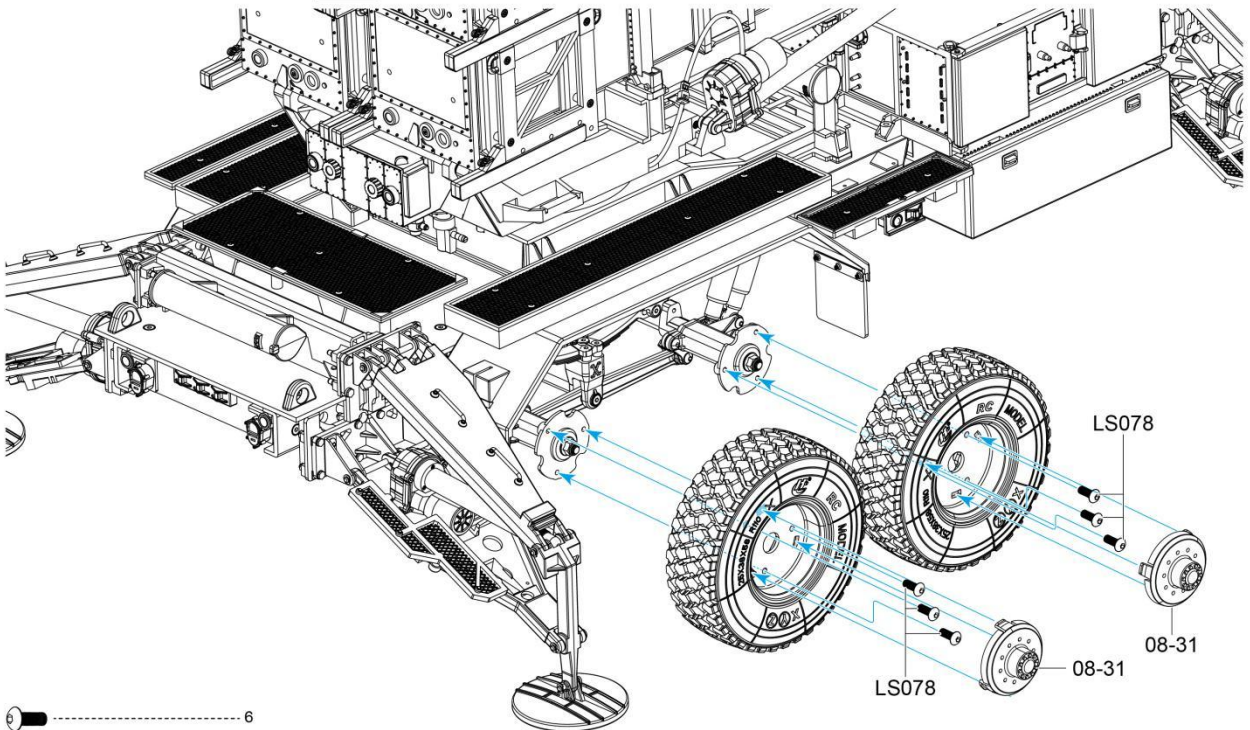

LS078 TM Ø3x8mm 6

139

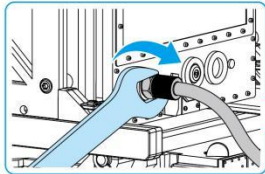
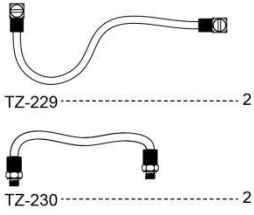

M7开口扳手  
M7 Open end wrench

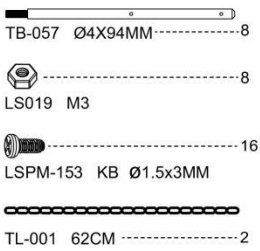
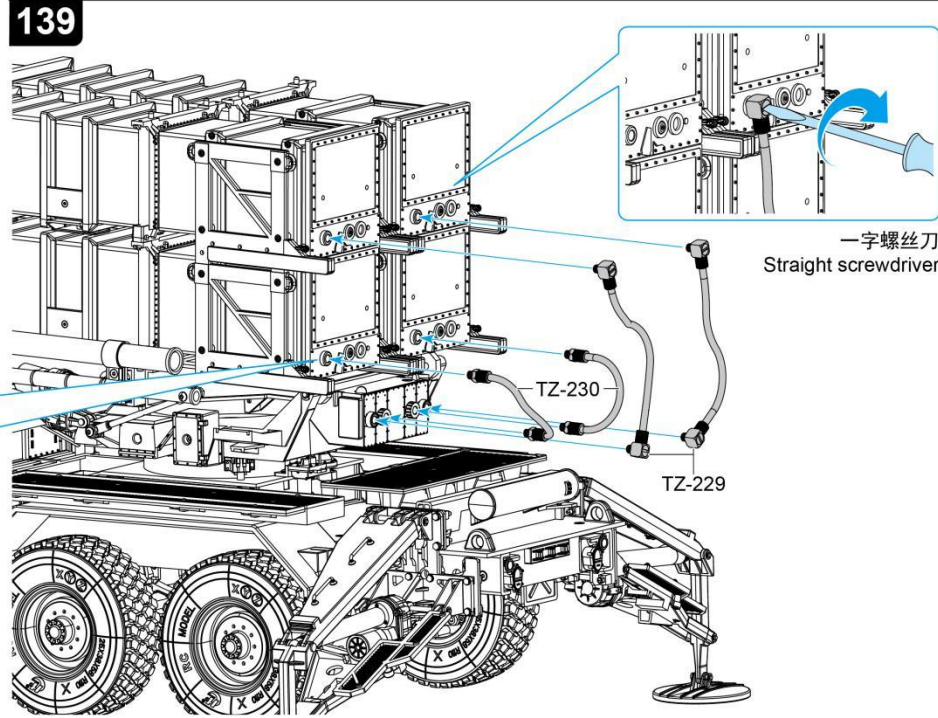

当螺丝穿过链子时，  
要注意选择链子上的  
螺丝位置，确保螺丝  
间距均衡。

When the screw passes  
through the chain, it is  
important to select the  
screw position on the  
chain and ensure that  
the screw spacing is  
balanced

140

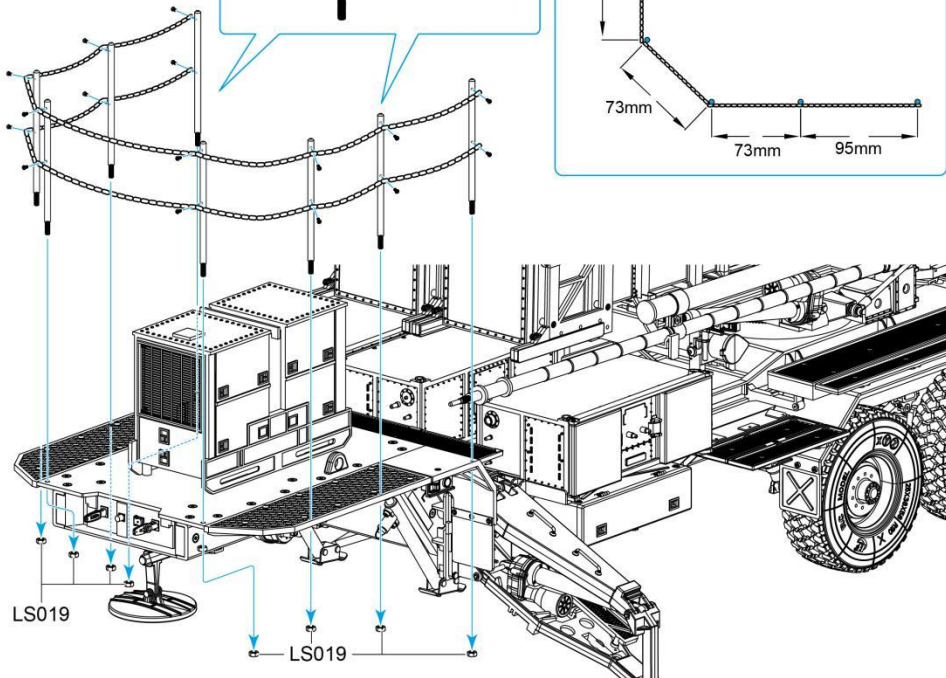
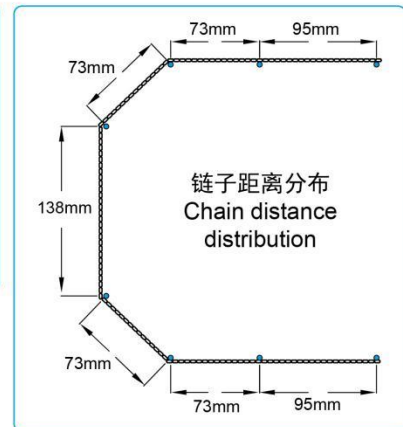
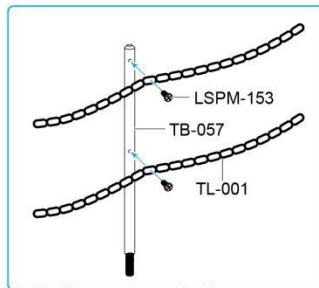

**注意**  
Caution



使用1.5mm内六角螺丝刀，插入联动拉杆中间孔位旋转，以此调整天线的垂直角度。

Use a 1.5mm hexagon screwdriver to insert into the middle hole of the linkage rod and rotate it to adjust the vertical angle of the antenna.

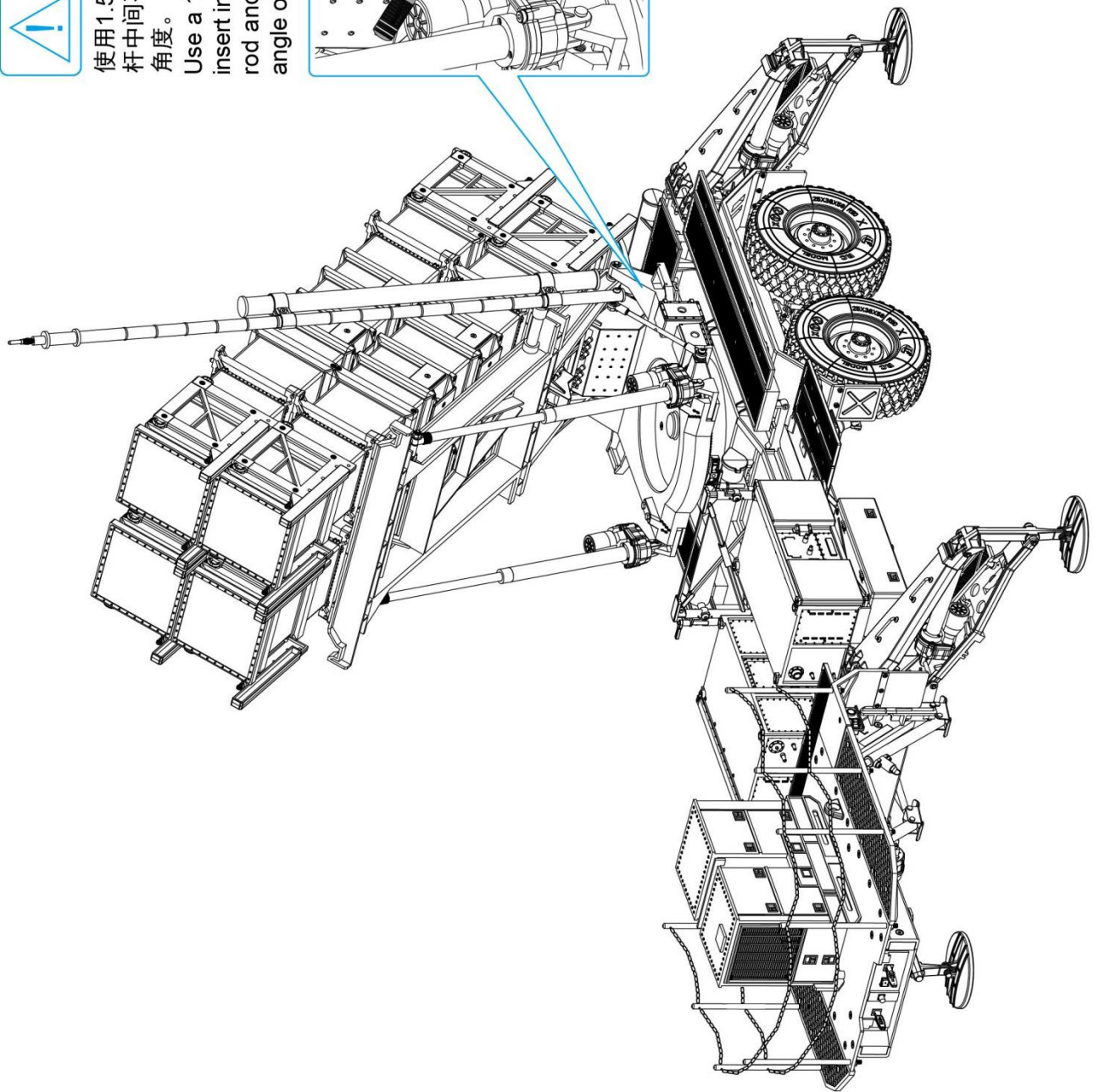
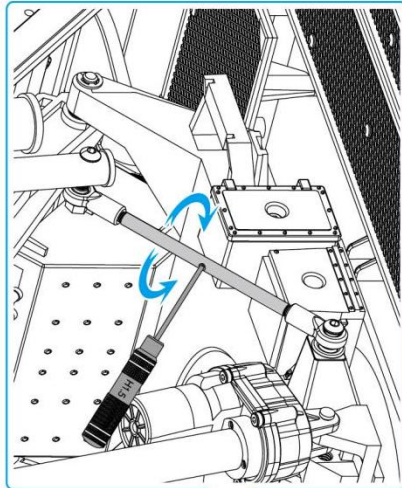

# 操作模式介绍 Operation Mode Introduction

## 1. 方控YK-003操控 (八通遥控器) Square control yk-003 control (eight way remote control)

将导弹车主控板上的信号延长线连接到前车拖头 (HG-P802) 接收机的数据通道POW, 能实现所有功能的操控以及车灯的开关。连接示意图如下: Connect the signal extension cable on the radar owner's control panel to the data channel POW of the front tractor (HG-P802) receiver to realize the control of all functions and the switch of lights. The connection diagram is as follows:

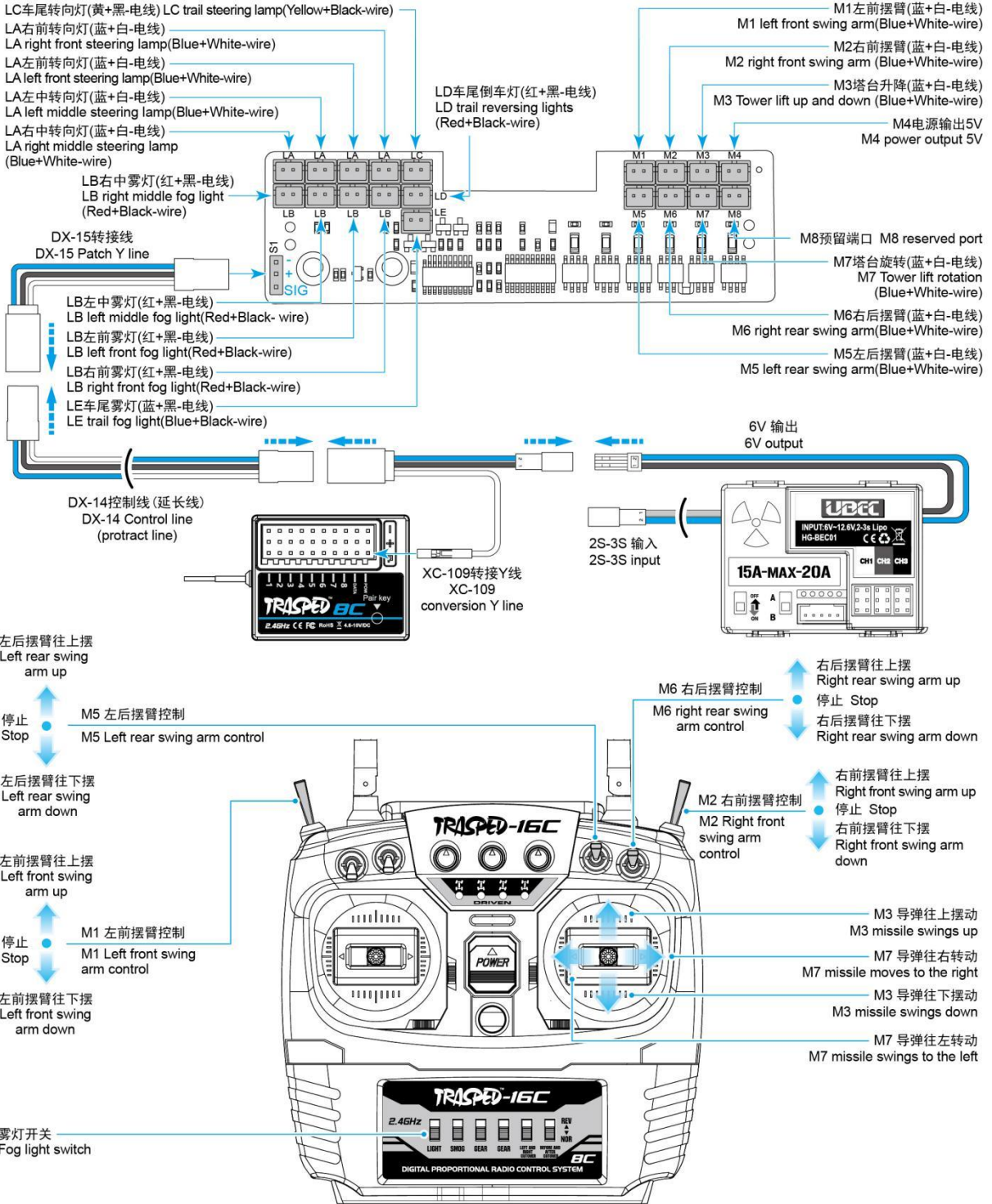



(2). 遥控器接收发射距离约30M。

(3). 对码操作:

- ①首次使用时, 将此处隔电片取掉(如图), 遥控器方可通电, 此时自动进入对频模式, 应立即接通小接收机电源(此时小接收机指示灯闪烁), 完成自动对频则小接收机指示灯长亮(不用时将隔电片插回, 可减少电池电量流失)。
- ②需要重新对频时, 同时按下M菜单功能键与对码键W并保持5秒以上, 待工作指示灯开始闪烁时松开功能键和对码键, 此时遥控器已进入对码模式。
- ③打开导弹车电源, 待遥控器的工作指示灯熄灭, 此时遥控器已对码完成。
- ④对码完成后, 同时按下M菜单功能键与F1功能键(F1功能键对应表格中“预设功能1”上面的功能)并保持5秒以上, 当工作指示灯开始闪烁时说明遥控器已选择对应的功能定义值。此时才能对导弹车进行操控。(注: 此步骤出厂已经设置完成)
- (4). 预设功能切换: 当遥控器需要对应不同产品使用时需从新对按键预设定义, 同时按下M菜单功能键与F2或F3功能键并保持5秒以上, 当工作指示灯开始闪烁时说明遥控器已选择对应的功能定义值。
- (5). F1-F9任一功能操作键, F1功能键对应导弹车; F2对应拖板车; F3对应吊臂; F4-F9空置(为预留设定通道, 后期对应不同产品时可进行功能定义)。
- (6). 工作指示灯: 当对遥控器进行操作时工作指示灯亮, 在遥控器指令发送完成后工作指示灯熄灭。
- (7). 当发射器发射指令时, 导弹车转向灯(黄色灯)为双闪状态, 雾灯(红色灯)为常亮状态, 当指令发送完成后(没有信号)时, 转向灯和雾灯延时亮至10秒后会自动熄灭。
- (8). 轻触M菜的功能键为雾灯(红色)开关。

(2). The receiving and transmitting distance of the remote control is about 30M.

(3). Code operation:

- ①When using for the first time, remove the power isolation sheet here (as shown in the figure), and the remote control can be powered on. At this time, it will automatically enter the linking mode, and the small receiver should be powered on immediately (the small receiver indicator flashes at this time). After the automatic linking is completed, the connection is all

The receiver indicator light is always on (plug the power isolation sheet back when not in use to reduce the loss of battery power).

- ②When you need to re-link the frequency, press the M menu function key and the code matching key W at the same time and hold for more than 5 seconds. When the work indicator starts to flash, release the function keys and the code matching key, and the remote control has entered the code matching mode.

- ③Turn on the power of the missile car, and wait for the remote control's working indicator to go out. At this time, the remote control has completed the code matching.

- ④After the code matching is completed, press the M menu function key and the F1 function key at the same time (the F1 function key corresponds to the function above the "preset function 1" in the table) and hold for more than 5 seconds. When the work indicator starts to flash, the remote control. The controller has selected the corresponding function definition value. Only then can the guided missile vehicle be controlled. (Note: This step has been set up at the factory)

- (4). Preset function switching: When the remote control needs to be used for different products, it is necessary to re-define the buttons, press the M menu function key and the F2 or F3 function key at the same time and hold for more than 5 seconds, when the work indicator starts to flash It means that the remote control has selected the corresponding function definition value.

- (5). F1-F9 any-function operation key, F1 function key corresponds to missile car; F2 corresponds to trailer truck; F3 corresponds to boom; F4-F9 is vacant (for reserved setting channel, function can be defined later when corresponding to different products).

- (6). Work indicator light: When the remote control is operated, the work indicator light is on, and the work indicator light is off after the remote control command is sent.

- (7). When the transmitter sends a command, the steering light (yellow light) of the missile vehicle is in a double flashing state, and the fog light (red light) is always on. When the command is sent (no signal), the turning light and fog light will be delayed. When it lights up to 10 seconds, it will automatically turn off Extinct.

- (8). Touch the function key of the M dish to switch the fog light (red).

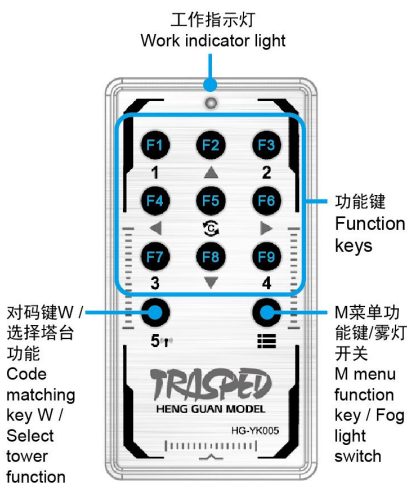
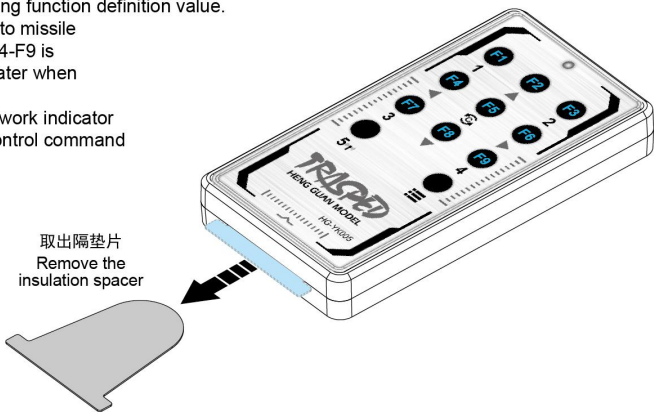

Function buttons 功能键	F1	F2	F3	F4	F5	F6	F7	F8	F9	W
预设功能 Preset functions	F1	F2	F3	F4	F5	F6	F7	F8	F9	W
预设功能 1 Preset functions 1	选择左前 Select left front	操作向上 Upward operation	选择右前 Select right front	塔台左转 Control tower turn left	选择全部 Select all	塔台右转 Control tower turn right	选择左后 Select left rear	操作向下 Downward operation	选择右后 Select right rear	选择塔台 Choose a tower
预设功能 2 Preset functions 2	空 Vacancy	向上 Upward	空 Vacancy	空 Vacancy	停止 Stop	空 Vacancy	空 Vacancy	向下 Down	空 Vacancy	空 Vacancy
预设功能 3 Preset functions 3	单杆缩短 Single pole shorten	主杆伸长 Main pole extend	双杆缩短 Double pole shorten	单杆伸长 Single pole extend	主杆缩短 Main pole shortened	双杆伸长 Double pole extend	绞盘收线 The winch take-up the wire	底盘逆时针旋转 Base anticlockwise rotation	底盘顺时针旋转 Base clockwise rotation	绞盘放线 The winch pay-off the wire
预设功能 4 Preset functions 4										
预设功能 5 Preset functions 5										
预设功能 6 Preset functions 6										
预设功能 7 Preset functions 7										
预设功能 8 Preset functions 8										
预设功能 9 Preset functions 9										

以下暂未定义  
Not defined yet



## 稳压电源UBEC参数 Regulated power supply UBEC parameters

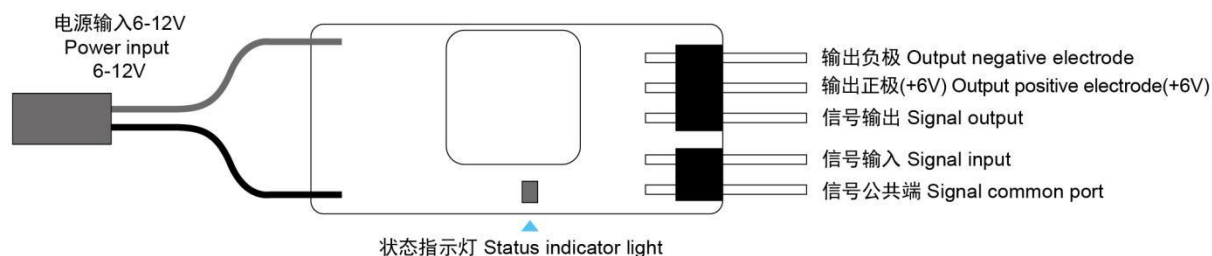

项目(Item)	规格参数描述 (Specifications)
输入电压(Input voltage)	DC6-12V
输出电压(Output voltage)	DC6V
输出电流(Output current)	6A
指示灯状态 (Indicator light status)	长亮：工作正常；闪烁：过流保护 Long bright: Works normally; Flashing: Overcurrent protection

## 主控制板额定参数 Rated parameters of main control board

项目(Item)	规格参数描述 (Specifications)
工作电源(Working power supply):	5.0V / 6.0V MAX / 3A - 6A
信号模式(Signal model):	串行数字数据(Serial digital data)
LA灯组输出电流(LA lamp group output power supply):	50 mA
LB灯组输出电流(LB lamp group output power supply):	40 mA
M1左前脚架输出电流(M1 left front tripod output current):	750 mA
M2右前脚架输出电流(M2 right front tripod output current):	750 mA
M3塔台升降输出电流(M3 tower lifting output current):	1000 mA
M4辅助供电(M4 auxiliary power supply):	5V / 1000 mA
M5左后脚架输出电流(M5 left rear tripod output current):	750 mA
M6右后脚架输出电流(M6 right rear tripod output current):	750 mA
M7塔台旋转输出电流(M7 tower lift rotation output current):	1200 mA
M8辅助供电(M8 auxiliary power supply):	5V / 1000 mA





# 零件 (PARTS)

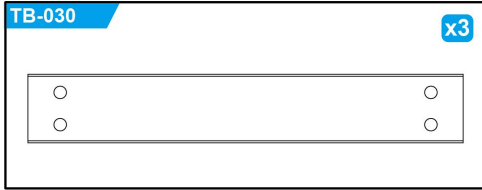

横梁方管  
Beam square tube

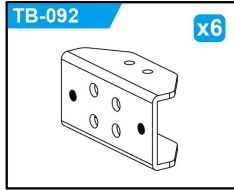

横梁铁片  
Beam iron

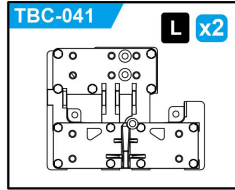

摆臂固定座(左)  
Swing arm holder(left)

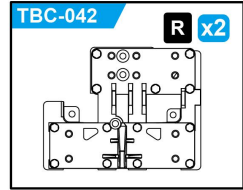

摆臂固定座(右)  
Swing arm holder(right)

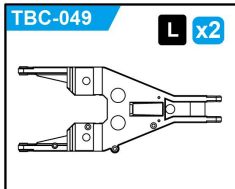

下摆臂(左)  
Lower arm(left)

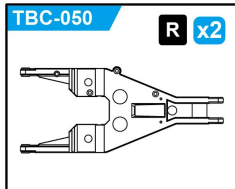

下摆臂(右)  
Lower arm(right)

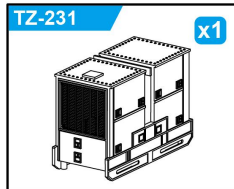

操控箱总成  
Operation box assembly

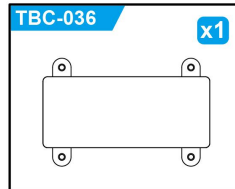

车板方孔盖  
Car plate square hole cover

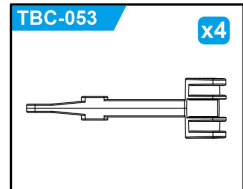

摆臂外支撑柱  
Swing outer support column

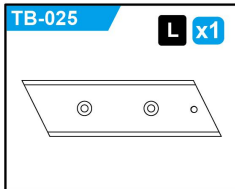

短大梁(左)  
Short beam(left)

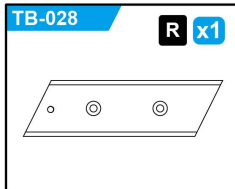

短大梁(右)  
Short beam(right)

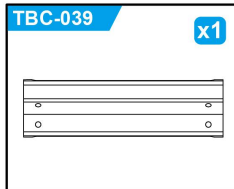

大梁连接块(上)  
Girder connection block (top)

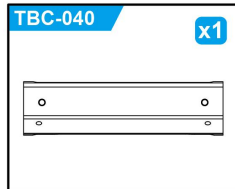

大梁连接块(下)  
Girder connection block (below)

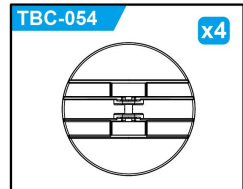

摆臂脚垫  
Swing arm pad

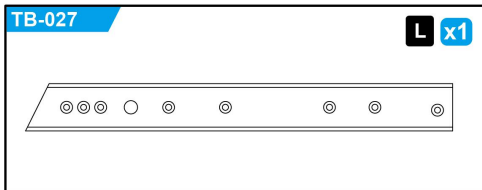

中大梁(左)  
Medium long beam(left)

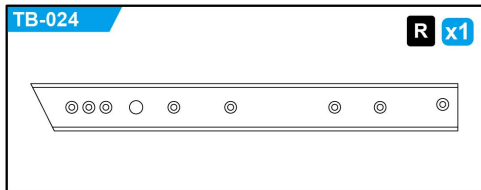

中大梁(右)  
Medium long beam(right)

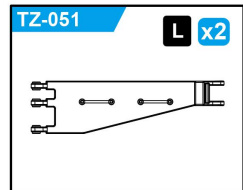

上摆臂(左)  
Upper swing arm(left)

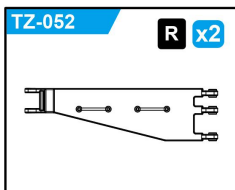

上摆臂(右)  
Upper swing arm(right)

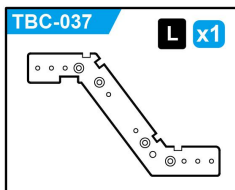

连接块(左)  
Connection block(left)

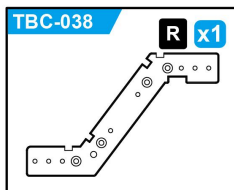

连接块(右)  
Connection block(right)

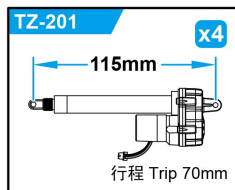

电动推杆(2号中长)  
Electric push rod  
(NO.2 medium length)



轮胎总成  
Wheel assembly

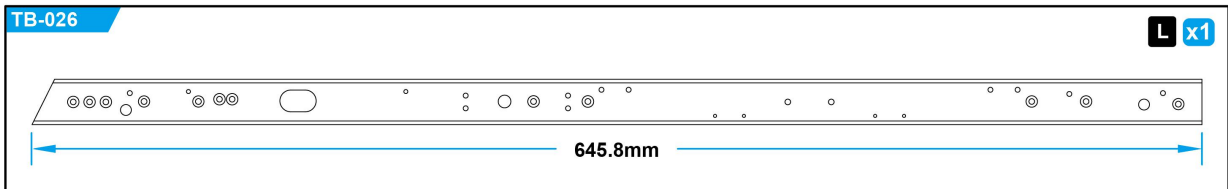

长大梁(左)  
Long beam(left)

TB-023

R x1

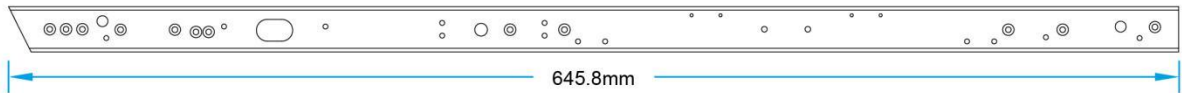

长大梁(右) Long beam(right)

TZ-202

x2

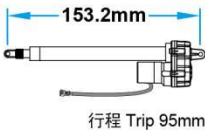

电动推杆(1号长)  
Electric push rod(NO.1 long)

TB-020

x1

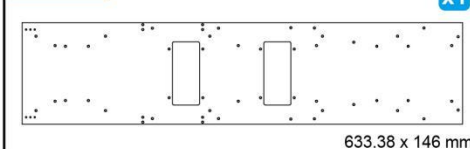

长车板  
Long car board

TB-021

x1

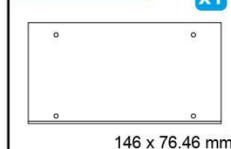

短车板(短)  
Short car board (short)

TB-022

x1

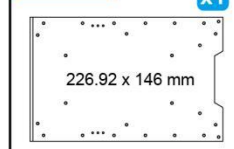

中车板(中)  
Medium car board (mid)

TB-020A

x1

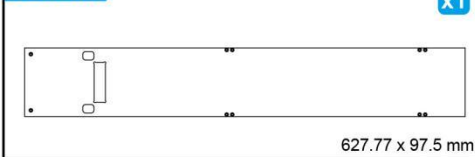

长底板 Long bottom plate

TB-021A

x1

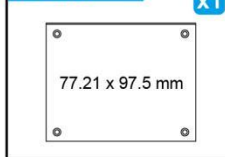

短底板(短)  
Short bottom plate (short)

TB-022A

x1

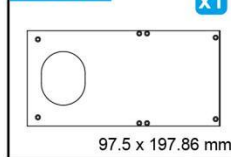

中底板(中)  
Medium bottom plate (mid)

TZ-209

L x1



左侧箱子组件  
Left box assembly

TZ-216

R x1



右侧箱子组件  
Right box assembly

TZ-214

L



脚架总成  
Tripod assembly

TZ-217

x1

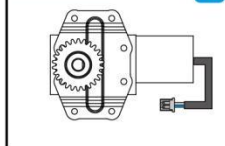

减速马达370  
Gear motor 370

DZ-A1



塑料横梁  
Plastic beam

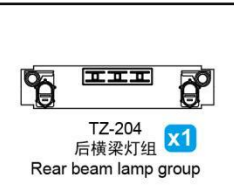

后横梁灯组  
Rear beam lamp group

DZ-A2



支撑铁片 Support metal plate



脚架支撑梁  
Tripod support frame



前挂钩连接梁  
Front hook connecting beam

DA-A4



减震 Damping



减震器总成  
Damping assembly

DA-A3



连接轴 Connecting axle



连接轴



连接轴

DA-A5



车轮连接配件 Wheel connection accessories



车轮连接配件



车轮连接配件



车轮连接配件



车轮连接配件



车轮连接配件



车轮连接配件

DA-A6

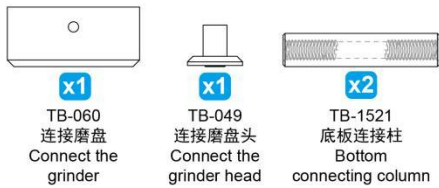

前挂钩 Front pothook

DA-A8

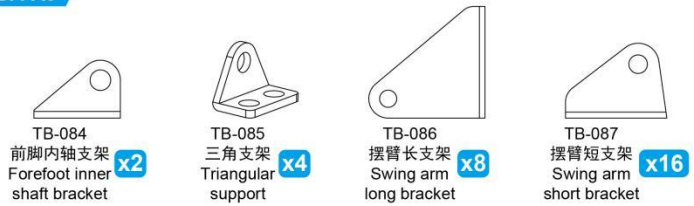

摆臂支撑片 Swing arm support sheet

DA-A7

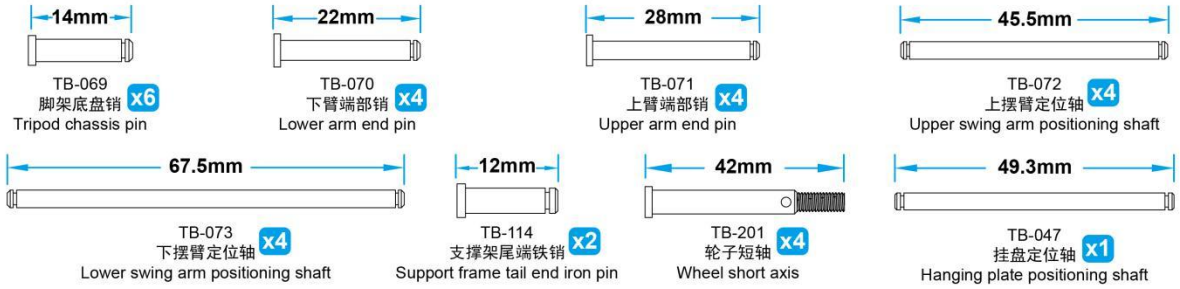

卡簧轴 Spring shaft

DA-A9

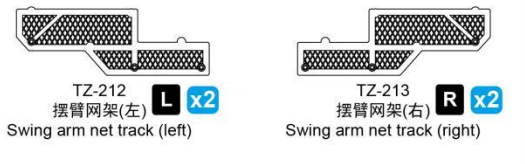

左右摆臂网架  
Left and right swing arm frame

DA-A9-1

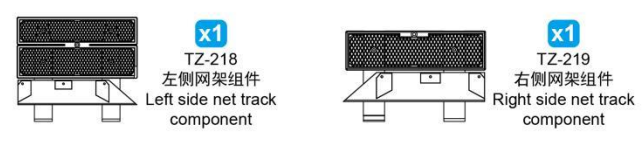

左右中段网架  
Left and right middle section grid

DA-A10

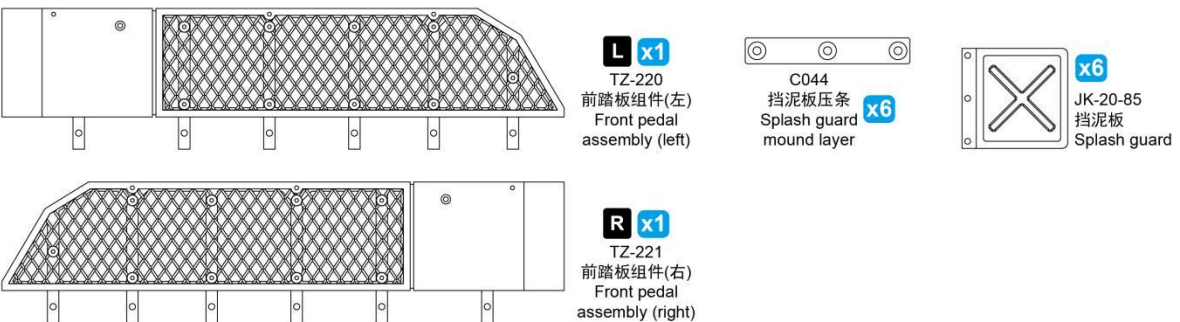

前踏板 Front pedal

DZ-A20

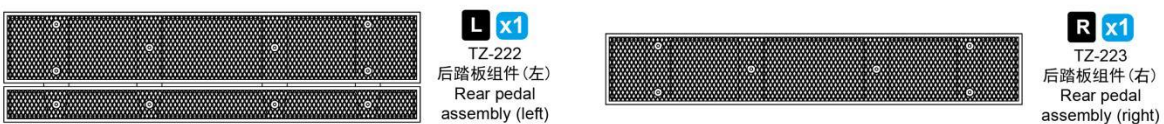

后踏板 Rear pedal

DA-A11

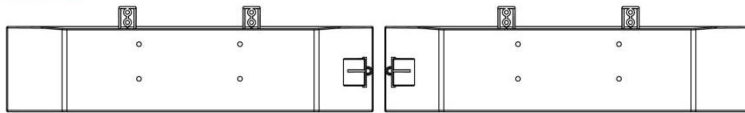

TBC-013  
后挡泥板(左) **L** x1  
Rear splash guard (left)

TBC-014  
后挡泥板(右) **R** x1  
Rear splash guard (right)

后挡泥板 Rear Splash guard

DA-A12

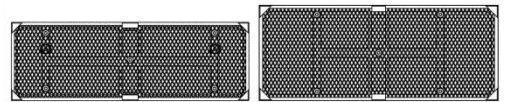

TZ-210  
前网架组件 **x1**  
Front net track component

TZ-211  
后网架组件 **x1**  
Rear side net track component

网架组件 Net track component

DA-A13

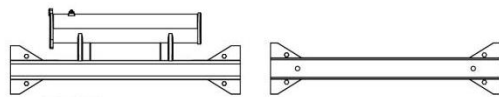

TZ-215  
后摆臂连接梁 **x1**  
Rear swing arm connecting beam

TBC-008  
前摆臂连接梁 **x1**  
Front swing arm connecting beam

上连接梁  
Upper connecting beam

8ASS-P0024

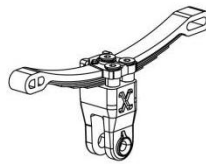

减震器总成  
Shock piece assembly

DZ-A28



DB-016  
转盘内齿轮 **x1**  
Turntable internal gear

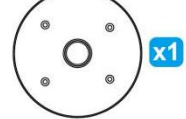

TBC-035  
导弹转盘盖 **x1**  
Missile turntable cover

转盘  
Turntable

TZ-227

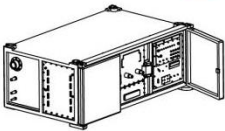

中控箱总成  
Central control box assembly

DD-001

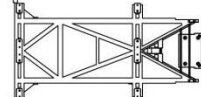

DD-001  
导弹支架 **x1**  
Missile support



DD-002  
定位支撑架 **x1**  
Positioning support frame

DZ-A24

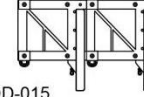

DD-015  
双层连接片(左) **L** **x4**  
Double-layer connecting piece (left)

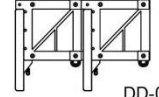

DD-016  
双层连接片(右) **R** **x4**  
Double-layer connecting piece (right)

双层连接片  
Double-layer connecting piece

DD-044



DD-028  
导弹底座盖 **x1**  
Missile base cover



DD-044  
导弹升降座 **x1**  
Missile lifter



DD-045  
推杆定位件 **x2**  
Push rod positioning piece

导弹升降座 Missile lifter

DD-046



DD-043  
导弹转向底座盖 **x1**  
Missile steering base cover



DD-046  
导弹转向底座 **x1**  
Missile steering base

TZ-224

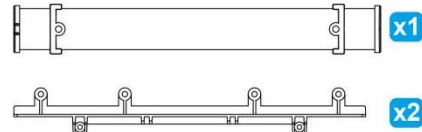

TZ-224  
圆管组件 **x1**  
Round tube assembly  
DD-029  
中置箱子托条 **x2**  
Middle box bracket

圆管组件 Round tube assembly

TB-029

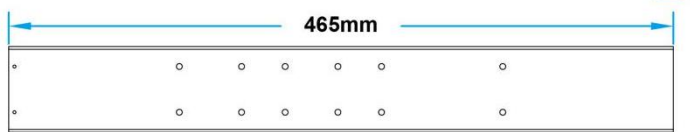

导弹仓方管 Missile warehouse square tube (60x60x2mm)

DZ-A22

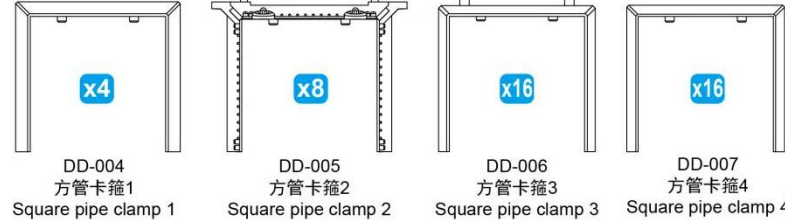

DD-004  
方管卡箍1 **x4**  
Square pipe clamp 1

DD-005  
方管卡箍2 **x8**  
Square pipe clamp 2

DD-006  
方管卡箍3 **x16**  
Square pipe clamp 3

DD-007  
方管卡箍4 **x16**  
Square pipe clamp 4

方管卡箍 Square pipe clamp

DZ-A22-2

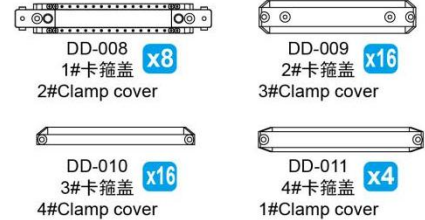

DD-008  
1#卡箍盖 **x8**  
2#Clamp cover

DD-009  
2#卡箍盖 **x16**  
3#Clamp cover

DD-010  
3#卡箍盖 **x16**  
4#Clamp cover

DD-011  
4#卡箍盖 **x4**  
1#Clamp cover

方管卡箍盖 Square pipe clamp cover

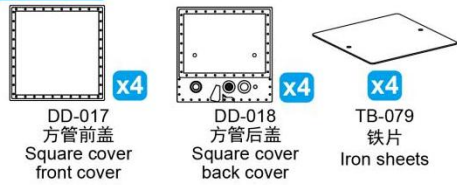
**DZ-A29**

DD-017 方管前盖  
Square cover front cover  
x4

DD-018 方管后盖  
Square cover back cover  
x4

TB-079 铁片  
Iron sheets  
x4

方管前后盖 Square tube front and rear cover

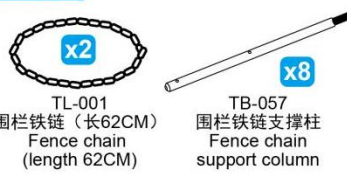
**DZ-A19**

TL-001 围栏铁链 (长62CM)  
Fence chain (length 62CM)  
x2

TB-057 围栏铁链支撑柱  
Fence chain support column  
x8

围栏铁链 Fence chain

**DZ-A23**

TZ-229 油管弯接头  
Tubing bay joint  
x2

TZ-230 油管直接头  
Tubing direct head  
x2

油管接头 Hose connector

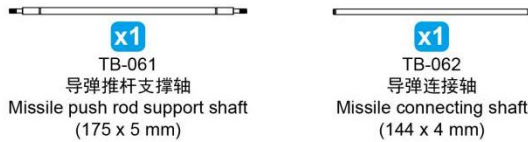
**DZ-A25**

TB-061 导弹推杆支撑轴  
Missile push rod support shaft  
(175 x 5 mm)  
x1

TB-062 导弹连接轴  
Missile connecting shaft  
(144 x 4 mm)  
x1

铁轴 Iron shaft

**DZ-A26**

DD-012 方管装饰条1  
Square tube decorative strip 1  
x8

DD-013 方管装饰条2  
Square tube decorative strip 2  
decorative strip 2  
x16

DD-014 方管装饰条3  
Square tube decorative strip 3  
decorative strip 3  
x16

方管装饰条 Square tube decorative strip

**DZ-A27**

TZ-225 底座组件1  
Base component 1  
x1

DD-032 底座配件3  
Base accessories 3  
x1

DD-033 底座配件4  
Base accessories 4  
x1

DD-034 底座配件5  
Base accessories 5  
x2

DD-035 底座配件6  
Base accessories 6  
x1

DD-041 底座配件10  
Base accessories 10  
x1

TZ-226 底座配件9  
Base accessories 9  
x1

底座配件 Base accessories

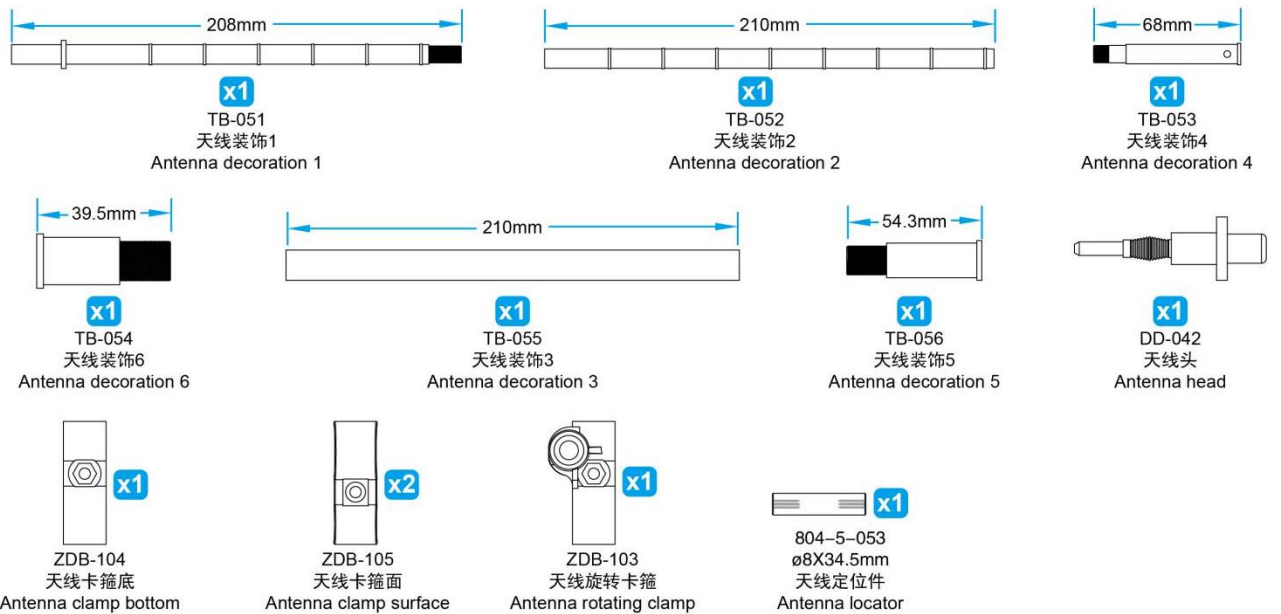
**DZ-A21**

TB-051 天线装饰1  
Antenna decoration 1  
208mm  
x1

TB-052 天线装饰2  
Antenna decoration 2  
210mm  
x1

TB-053 天线装饰4  
Antenna decoration 4  
68mm  
x1

TB-054 天线装饰6  
Antenna decoration 6  
39.5mm  
x1

TB-055 天线装饰3  
Antenna decoration 3  
210mm  
x1

TB-056 天线装饰5  
Antenna decoration 5  
54.3mm  
x1

DD-042 天线头  
Antenna head  
x1

ZDB-104 天线卡箍底  
Antenna clamp bottom  
x1

ZDB-105 天线卡箍面  
Antenna clamp surface  
x2

ZDB-103 天线旋转卡箍  
Antenna rotating clamp  
x1

804-5-053  
ø8X34.5mm  
天线定位件  
Antenna locator  
x1

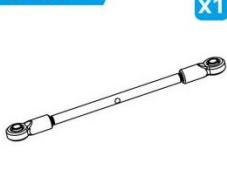
**TZ-228**

TZ-228 天线联动杆  
Antenna linkage rod  
x1

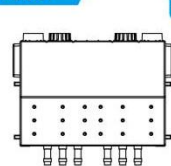
**DD-003**

DD-003 变电箱  
Transformer box  
x1

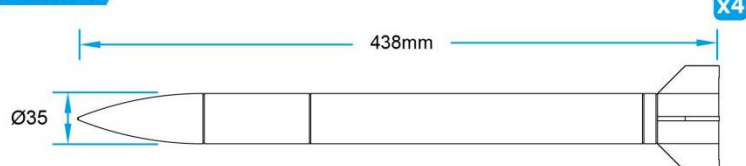
**HG-PAC-04**

HG-PAC-04 导弹模型(另购)  
Missile model(purchased separately)  
438mm  
ø35  
x4



## 电子类 Electronics

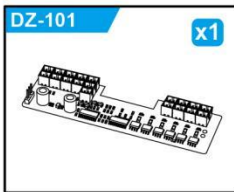

**DZ-101** x1  
LS-HG317-CTRL  
主控制板  
Main control board

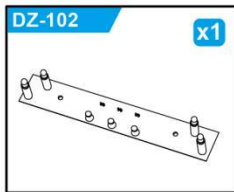

**DZ-102** x1  
LS-HG317-LED  
尾灯板  
Taillight board board

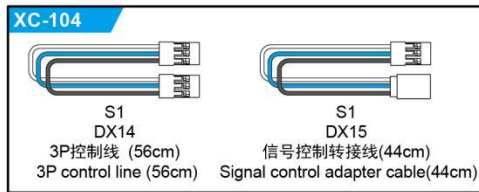

**XC-104**  
S1 DX14 3P控制线 (56cm)  
3P control line (56cm)  
S1 DX15 信号控制转接线(44cm)  
Signal control adapter cable(44cm)

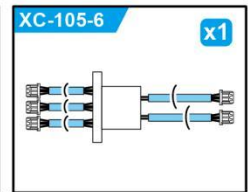

**XC-105-6** x1  
6路导电滑环  
6-way conductive slip ring

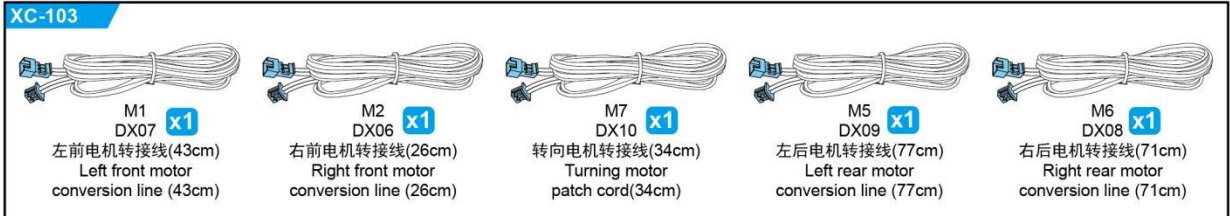

电机连接线  
Motor connection line

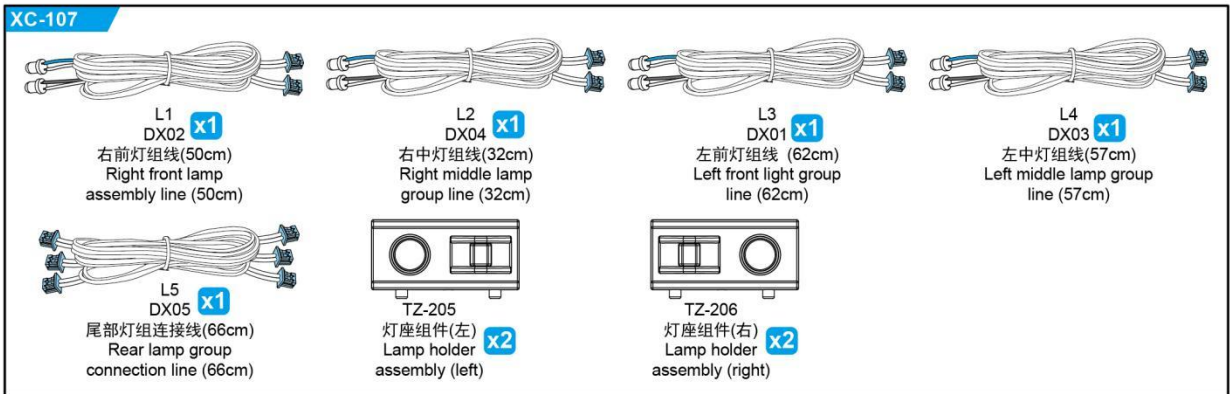

灯组连接线  
Light group connection line

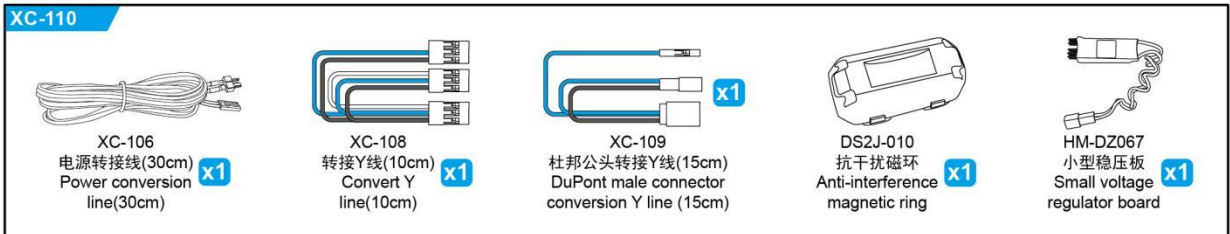

转接线 Conversion line

## HTBD-016 工具袋 HTBD-016 tool bag

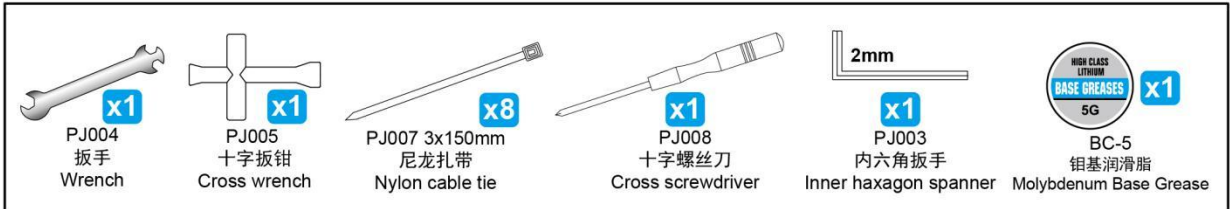

辅助工具 Auxiliary tool

## 附属配件 Affiliated fittings

### BS02-A4



说明书 Instruction book

### LSD-8ASS-1.5

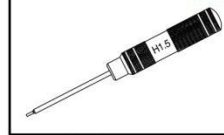

### LSD-8ASS-2.0

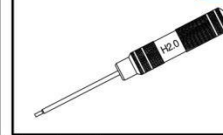

### LSD-8ASS-2.5

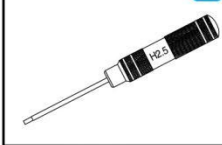

### TBASS-02



小遥控器套装 Small remote controller suit

### D3

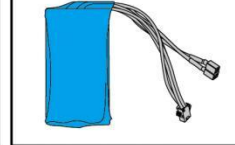

## 805零件盒LS1 HG-P805 Parts Box LS1

<p>x103 LS001 TM Ø3X6</p>	<p>x74 P002 KM Ø3X6</p>	<p>x12 LS100 TM Ø2X6</p> <p>x4 P007 HM Ø2X4</p> <p>x2 W05014 HM Ø3X8</p>	<p>x5 LS083 TM Ø3X16</p> <p>x14 LSZ0701 TM Ø3X5</p> <p>x2 LSTB-310 TB Ø3X10</p>	<p>x27 LS078 TM Ø3X8</p> <p>x64 LSKB-210 KB Ø2X10</p>
<p>x34 P001 KM Ø3X8</p> <p>x8 W05016 KM Ø2X6</p>	<p>x36 LSKB-38 KB Ø3X8</p> <p>x16 W05007 TM Ø3X14mm</p>	<p>x32 LSTB-38 TB Ø3X8</p> <p>x26 P544 KB Ø2X6</p>	<p>x8 LSPB-174 PB Ø1.7X4</p> <p>x2 LS002 TM Ø3X10</p>	<p>x1 W05021 TM Ø3X25</p> <p>x6 LS089 KM Ø3X14</p> <p>x9 W05019 TM Ø3X12</p>

## 805零件盒LS2 HG-P805 Parts Box LS2

<p>x88 LSKB-212 KB Ø2x12</p> <p>x4 TB-043 Ø3.2X6X4.5</p> <p>x8 LS225 Ø5xØ9x3mm</p>	<p>x4 W01003 Ø2X10mm</p> <p>x42 LS023 2mm</p> <p>x2 W04003 Ø4X7X2.5</p>	<p>x34 W05009 HM Ø2X6</p> <p>x1 A1-002 Ø3.1x5x13</p> <p>x1 CU-01 Ø3.1x5x6.5x6.5</p> <p>x16 LS776 KM Ø2X8</p>	<p>x8 LSKM-312 KM Ø3x12MM</p> <p>x4 P1501 KM Ø3X10</p> <p>x16 W05011 HM Ø2x10</p>	<p>x1 LSKM-318 KM Ø3x18MM</p> <p>x1 LSKB-05 KB Ø2X5</p> <p>x24 KB143 KB Ø1.4X3</p>
<p>x16 LSKM-210 KM Ø2x10</p> <p>x4 W1037 Ø3XØ5X3mm</p> <p>x4 LS15003 Ø5.1XØ7X0.4mm</p>	<p>x3 LS022 M3</p> <p>x16 LS020 M2</p> <p>x2 C898 M3</p> <p>x2 LS024 M4</p>	<p>x8 TB-8058 Ø6.5X10.5mm</p> <p>x8 W141 Ø3</p> <p>x13 LS019 M3</p> <p>x8 G10611 KM Ø2.5x6</p>	<p>x4 W1040 Ø3.1X4X7.5</p> <p>x6 LS016 PB Ø2X6mm</p> <p>x4 W05012 HM Ø2.5X6</p>	<p>x4 W05001 M4</p> <p>x5 LSTB-26 TB Ø2x6MM</p> <p>x16 LSPM-153 KB Ø1.5X3</p>

## HG-P805 产品性能参数 Product performance parameters

- |                                       |  |
|---------------------------------------|--|
| 1. 最大爬坡角度: 15°/坡长2m                   | 1. Maximum climbing angle: 15°/slopes length: 2 meters;        |
| 2. 最多转弯半径: 2m                         | 2. Maximum radius of turning circle: about 2 meters;           |
| 3. 最大跨越宽度: 100mm                      | 3. Maximum span width: 100mm                                   |
| 4. 底盘离地间隙: 85mm                       | 4. Chassis ground clearance: 85mm                              |
| 5. 轮胎可悬空距离: 5mm                       | 5. Tire can be suspended distance: 5mm                         |
| 6. 导弹发射塔升降角度: 45°                     | 6. Lifting angle of missile launching tower: 45°               |
| 7. 支撑脚升降角度: 91°                       | 7. Lifting angle of supporting feet: 91°                       |
| 8. 导弹收缩最小尺寸:<br>917mmX324.5mmX373.5mm | 8. Minimum shrink size of missile:<br>917mmX324.5mmX373.5mm    |
| 9. 导弹伸展最大尺寸:<br>917mmX493.5mmX653.5mm | 9. Maximum size of missile extension:<br>917mmX493.5mmX653.5mm |
| 10. 产品净重: 13KG                        | 10. The whole car weight: 13KG                                 |
| 11. 伸缩杆最大推拉力: 30KG                    | 11. Maximum push-pull force of telescopic rod: 30KG            |

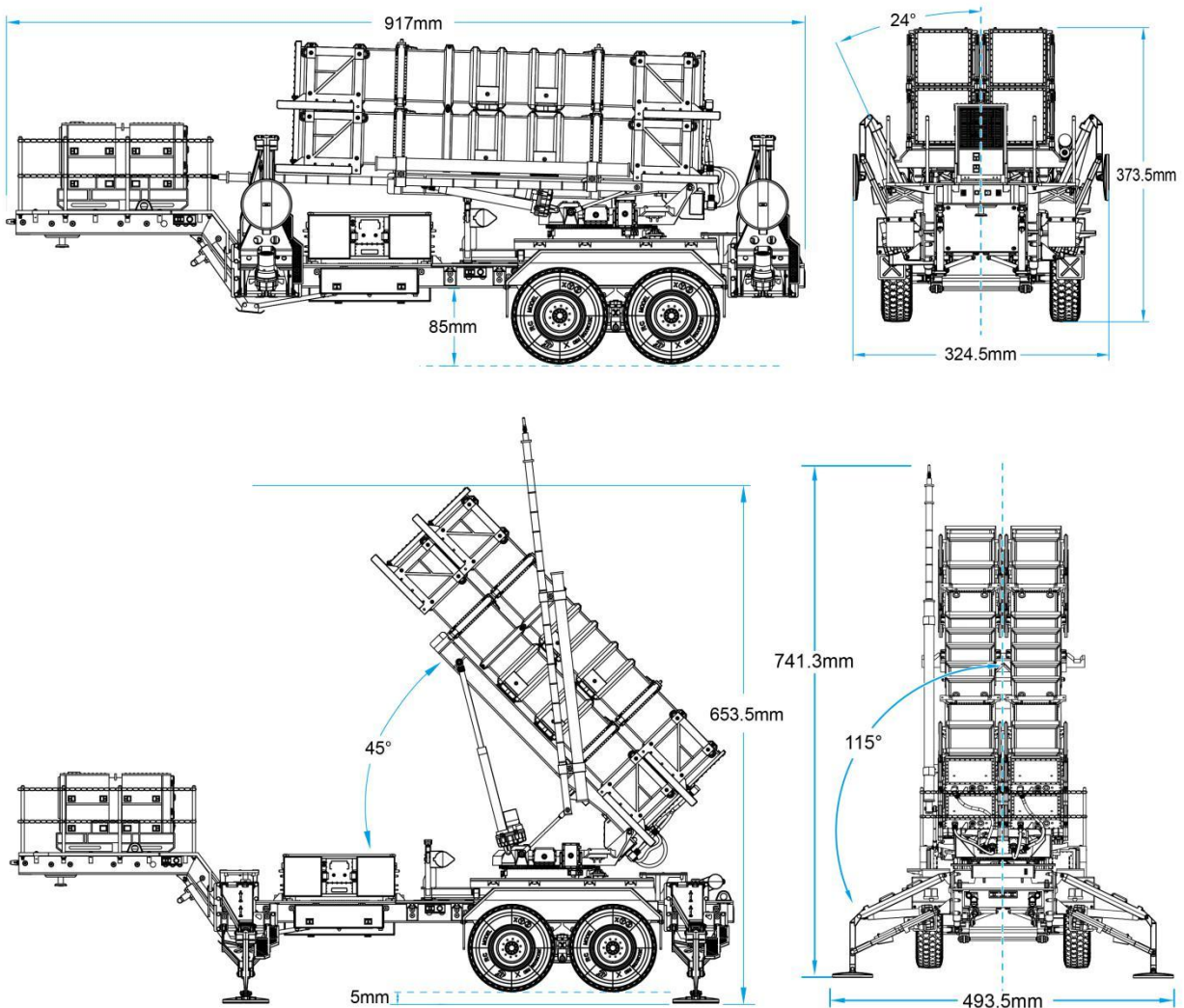

## 解决问题指引 Solutions to problems

问题 Problem	原因 Cause	处理方法 Processing Method
模型不动 Model fails to move	模型中电池电量不足。 The model is of low battery.	请将旧电池取下充电, 和安装充满电的电池或没有装入电池。 Please remove the old batteries to charge, and put in fully-charged batteries or no batteries.
	没有对频 No on the frequency	请按照说明书上的对频方法重新对频。 Please reset the frequency according to the frequency matching method in the instruction book.
	连接电线破损或插头线松脱 The connection wire is broken or the plug wire is loose.	1.立即断电检查电线破损部位, 重新连接并做好绝缘处理, 2.重新将插头插紧固定好, 全部仔细检查确认无误后方可通电测试。 1. Immediately cut off the power, check the damaged part of the wire, reconnect it and make insulation treatment. 2. Reinsert the plug and fix it, and check it carefully before power-on test. Control panel short circuit.
	控制板短路 Control panel short circuit	更换新的控制板, 非专业用户切勿盲目维修。 Replace the new control panel, non-professional users don't blind maintenance.
	插头线错接 The plug is incorrectly connected	根据说明书上内容重新接入插头, 接线或插线时请认准编号和电源的正负极, 防止反接。 Reconnect the plug according to the instruction book, when wiring or inserting the wire, please check the number and positive and negative terminals of the power to prevent reverse connection.
	超出遥控范围 Out of range	1. 及时拉近遥控距离; 2. 移至空旷地面或其他合适的场地操控。 1. Shorten the distance of remote control in time. 2. Move to open ground or other suitable field control.
车灯不亮 The lamp is not bright	车灯开关没有打开 The light switch is not on	打开车灯 Open the lamp
	车灯线插头接触不良 The contact with lamp wire plug is bad	1. 将主控板上的插头重新插紧; 2. 仔细检查电线是否有破损现象, 如有请重新连接并做好绝缘处理; 3. 确认无误后方可通电测试。 1. Insert the plug on the main contact board tightly. 2. Carefully check whether the wire is damaged, if yes, please reconnect and do insulation treatment; 3. Confirm the power-on test.
	电量不足 Battery is low	更换新的电池或为电池充电。 Replace or charge the battery.
组装问题 The assembly problem	表面涂层过厚 The surface coating is too thick	由于喷漆涂层过厚导致部分配件装配过紧属于正常现象, 可使用橡胶锤或锉刀作适当修整。 It's normal to assemble some parts too tightly due to the thick spray coating, you can use a rubber hammer or file for proper dressing.
	配件轻微变形 Fittings slightly deformed	1. 由于个别配件出现轻微的变形导致孔位对不上或其他边围衔接不顺, 可以适当先松动关联螺丝后再用力强制锁正和接顺。 2. 变形严重可更换完整部件。 1. Due to the slight deformation of some accessories, the hole position isn't on or the other side of the connection isn't smooth, you can loosen the associated screw properly first and then force the lock and connection. 2. Complete parts can be replaced if deformed seriously.

## 解决问题指引 Solutions to problems

问题 Problem	原因 Cause	处理方法 Processing Method
<p>电动伸缩杆异常（注意：非专业用户切勿随意拆卸电动伸缩杆，有问题请立即找专业人员维修或更换新的伸缩杆）</p> <p>Electric telescopic rod is abnormal (Note: Non-professional users shouldn't disassemble the electric telescopic rod at will. If there is a problem, please find a professional to repair or replace the new telescopic rod immediately. Otherwise)</p>	<p>噪声尖锐且刺耳</p> <p>The noise is sharp and harsh.</p>	<ol style="list-style-type: none"> <li>1. 加入适量的润滑油；</li> <li>2. 减速齿轮装配不到位，需要重新拆解查看；</li> <li>3. 更换新的伸缩杆。</li> </ol> <p>1. Add the right amount of lubricating oil;</p> <p>2. The reduction gear assembly isn't in place, and it needs to be disassembled and viewed again;</p> <p>3. Replace the telescopic rod.</p>
	<p>电机工作异常</p> <p>Abnormal motor operation</p>	<ol style="list-style-type: none"> <li>1. 更换新的电机；</li> <li>2. 找专业人员维修。</li> </ol> <p>1. Replace the new motor;</p> <p>2. Find a professional maintenance.</p>
	<p>伸缩不到位</p> <p>Expansion is not in place</p>	<ol style="list-style-type: none"> <li>1. 电池电量过低导致，立即充电或更换新电池；</li> <li>2. 拆卸两端接头手动旋转几圈伸缩杆，使其充分润滑后再装回；</li> <li>3. 更换新的伸缩杆。</li> </ol> <p>1. If the battery is at least low, charge or replace the battery immediately;</p> <p>2. Remove the connecting heads at both ends and manually rotate the telescopic rod several times to make it fully lubricated and then reinstall.</p> <p>3. Replace the telescopic rod with a new one.</p>
	<p>伸缩杆帽头易脱落</p> <p>Telescopic rod cap is easy to fall off</p>	<p>拆卸伸缩杆帽头连接端，重新拧紧帽头再装回。</p> <p>Remove the connecting end of the telescopic rod cap head, tighten the cap head again and reinstall it.</p>
	<p>伸缩正反转错乱（电机连接线反接）</p> <p>Expansion and reverse rotation disorder (motor connection line reverse connection)</p>	<ol style="list-style-type: none"> <li>1. 拆下伸缩杆并拔下连接插头；</li> <li>2. 拆下电机，认准正负极（正反转）重新焊接电机连接线的正负极。</li> </ol> <p>1. Remove the telescopic rod and pull down the connecting plug;</p> <p>2. Remove the motor, identify the positive and negative electrodes (positive and negative rotation) and re-weld the positive and negative plates of the motor connection line.</p>
<p>伸缩杆卡死</p> <p>The telescopic rod is stuck</p>	<ol style="list-style-type: none"> <li>1. 电池电量不足，需充电或更换新电池；</li> <li>2. 依次拆开内管头、外管头、硅胶圈、外管、内管后露出丝杆，在丝杆上涂抹适量润滑油，增加润滑，再装回测试；</li> <li>3. 在外管头下再增加一个硅胶圈来限位。（如下分解图所示）</li> </ol> <p>1. If the battery is low, charge it or replace it with a new one.</p> <p>2. Disassemble the inner tube head, the outer tube head, the silicone ring, the outer tube, and the inner tube in turn to expose the screw rod, apply a proper amount of lubricating oil on the screw rod to increase the lubrication, and then reinstall it for testing;</p> <p>3. Add a silicone ring under the outer tube head to limit the position. (As shown in the below diagram)</p>	

## 分解图 Exploded view

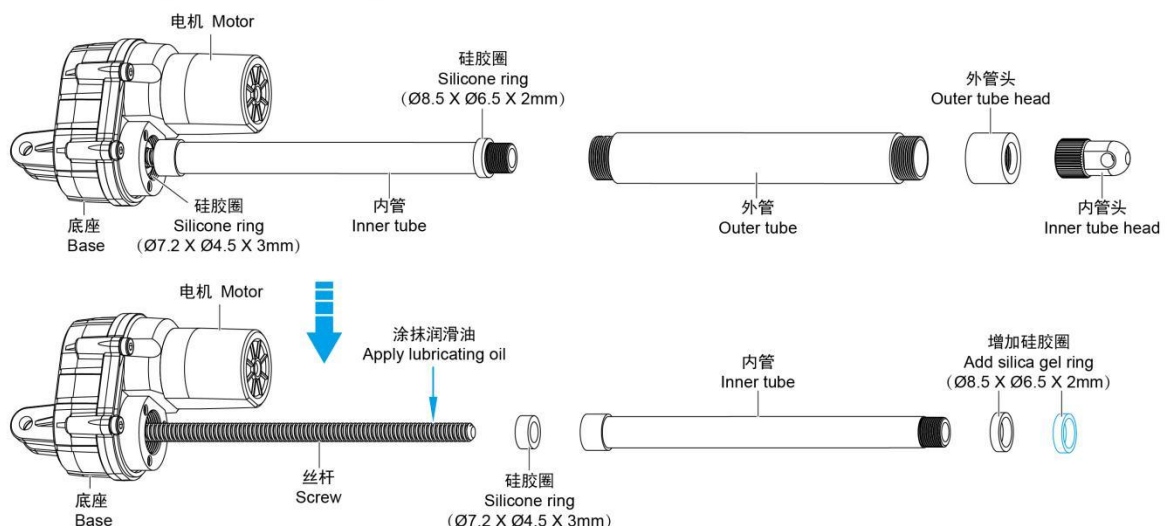

**1/12 SCALE  
U.S. RADAR VEHICLE AND  
MISSILE LAUNCH VEHICLE**

**HG-P804**

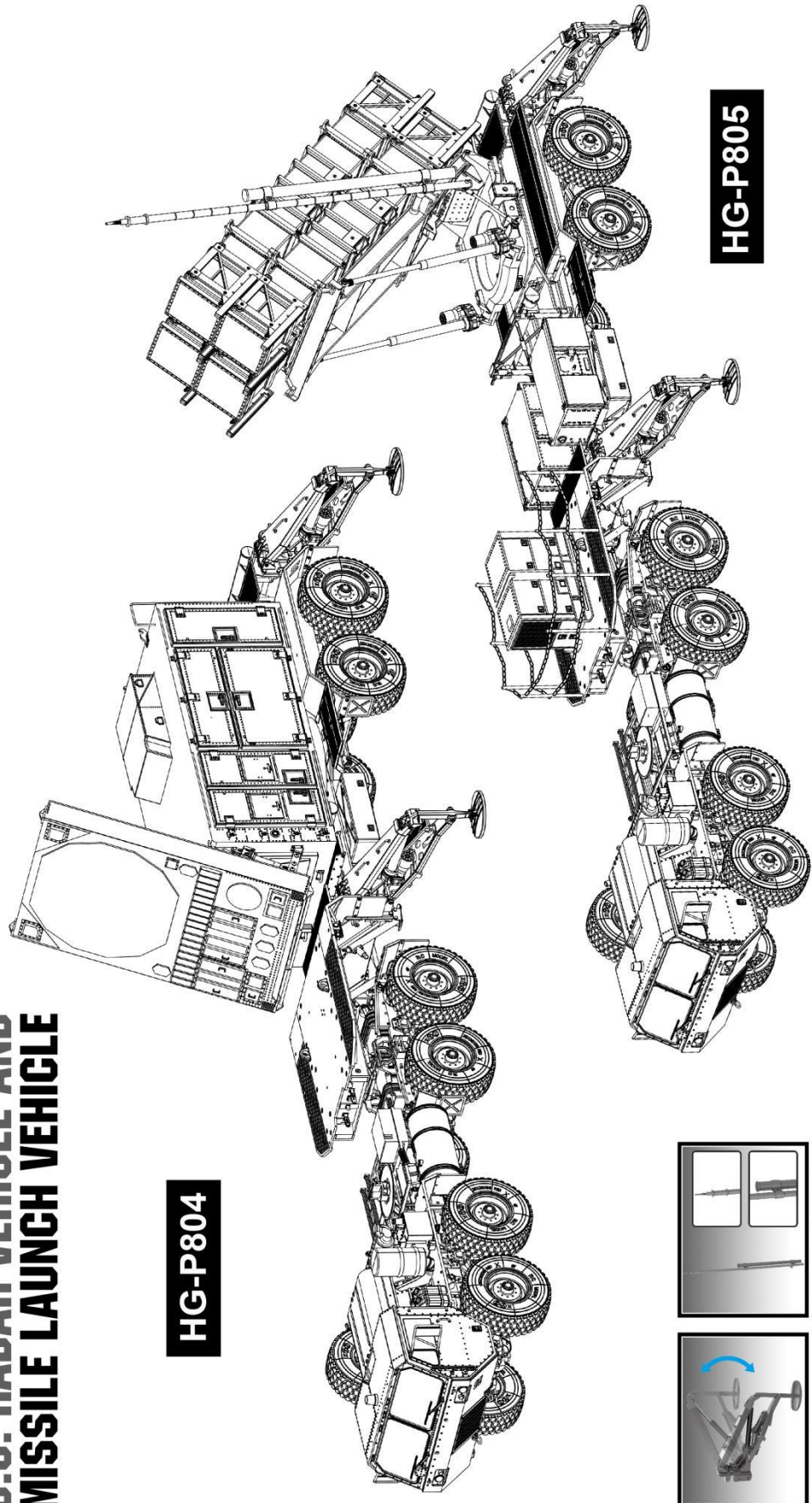

**HG-P805**



4 Trailer Stabilizer

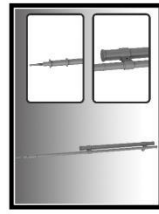

Antenna Mast For Launching Pad



Telescopic Rod Assembly

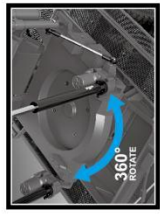

Can Be Rotated 360°



Tallight Combination



Surface Details Of Semitrailer Bottom

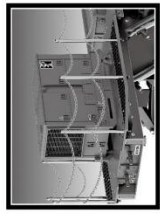

Generator Set



Electrical Launch Control Module



Bottom Details Of Missile Launcher

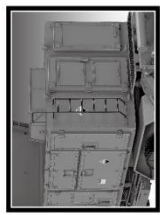

Close-up On The Back

## 警告(Warning):

本产品含有小零件请勿让三岁以下儿童玩耍；本品含电子元件，不得入水或在潮湿环境下使用；电池充电器应定期检查其电线、插头、外壳和其他部件是否损坏，发现损坏时应停止使用。

Choking hazard! This product contains small parts. NOT suitable for children under 3 years. Contains electrical components and should be kept dry at all times. Regularly check the battery charger wires, plugs and shell and other components for damage. DO NOT use if any part is damaged.

### 注意事项 (Warnings & Cautions)

1. 可拆卸的小零件要放好，千万不可让小孩吞食。
  2. 如操作场地有电波干扰，请另选场地操作。
  3. 遥控器电源低电时，请立即停止操作。
  4. 对拆除后的包装物，请不要随地丢弃，以免污染环境。
  5. 请将您的遥控模型存放在干燥、阴凉的地方。
  6. 不要置于近火和高温、潮湿的地方储存。
  7. 当电池被水浸湿，请将水分充分地擦拭干净，如有变形，请停止使用。
1. Detachable small parts should be stored safely and out of reach of children.  
2. If interference is experienced, turn the model off and try it again in a different area.  
3. Remote controller will not function correctly if the batteries are low. Please replace the batteries.  
4. Please discard old/used batteries in a safe manner. Consider your environment!  
5. Please store the remote control model in cool, dry place.  
6. DO NOT expose to fire or high temperatures, do not store in moist place.  
7. Once the battery get wet, wipe immediately with a soft dry cloth.  
If the battery any deformation, please stop using

### 电池使用注意事项(Precautions for battery use)

1. 车体使用2S 7.4V 18650 锂电池。
  2. 遥控器使用3V钮扣电池。
  3. 安装或更换电池时请注意极性。
  4. 充电电池只能在成人监护下充电。
  5. 不可混用新旧或不同型号的电池。
  6. 电池电量用尽后，应从模型内取出。
  7. 接线端不应短路。
  8. 非充电电池不可充电。
  9. 充电电池充电前应从模型中取出。
  10. 请不要将坏的电池、电池组分解或扔到火中、水里，以免发生意外。
  11. 充电器的额定输入电压必须与当地的家用电压相符。
  12. 在充电过程中，充电器和电池出现微温，属于正常现象。
1. Bodywork uses 2S 7.4V 18650 Lithium battery.  
2. Remote controller uses 3V button battery.  
3. Please pay attention to correct polarity when replacing batteries.  
4. Rechargeable batteries should be charged under adult supervision.  
5. DO NOT use a mix of old and new or different types of battery.  
6. After the battery is exhausted, the model should be removed.  
7. DO NOT short circuit any terminals.  
8. DO NOT attempt to recharge non rechargeable batteries.  
9. Remove batteries from the model when charging.  
10. DO NOT put batteries into a fire or into water.  
11. The rated input voltage battery charger MUST be suitable for your mains power voltage.  
12. During charging it is quite normal for the charger and batteries to heat up.



本产品说明书内容仅供参考。本公司有权对产品进行更改或调整，恕不再另行通知，具体请以官方为准。  
The instruction sheet for this product is just for your reference. We reserve the right to make changes or adjustments on the product without prior notification. Please refer to the official information.

---

REMOTE CONTROL MODEL SERIES

# 1/12 U.S. MISSILE LAUNCH VEHICLE

---

TRASPED

[hengguantoys.en.alibaba.com](http://hengguantoys.en.alibaba.com)



**KIT SELF ASSEMBLY**

---